

Dynamical Analogies

In the manufacture of this book, the publishers have observed the recommendations of the War Production Board with respect to paper, printing and binding in an effort to aid in the conservation of paper and other critical war materials.

Dynamical Analogies

By

HARRY F. OLSON, E.E., PH.D.

*Acoustical Research Director
RCA Laboratories, Princeton, New Jersey*



NEW YORK

D. VAN NOSTRAND COMPANY, INC.

250 FOURTH AVENUE

1943

Copyright, 1943, by
D. VAN NOSTRAND COMPANY, INC.

All Rights Reserved

*This book, or any parts thereof, may
not be reproduced in any form without
written permission from the publishers.*

Printed in U. S. A.

PREFACE

Analogies are useful for analysis in unexplored fields. By means of analogies an unfamiliar system may be compared with one that is better known. The relations and actions are more easily visualized, the mathematics more readily applied and the analytical solutions more readily obtained in the familiar system.

Although not generally so considered the electrical circuit is the most common and widely exploited vibrating system. By means of analogies the knowledge in electrical circuits may be applied to the solution of problems in mechanical and acoustical systems. In this procedure the mechanical or acoustical vibrating system is converted into the analogous electrical circuit. The problem is then reduced to the simple solution of an electrical circuit. This method has been used by acoustical engineers for the past twenty years in the development of all types of electro-acoustic transducers. Mechanical engineers have begun to use the same procedure for analyzing the action of mechanisms.

The importance and value of dynamical analogies to any one concerned with vibrating systems have led to a demand for expositions on this branch of dynamics. Accordingly this book has been written with the object of presenting the principles of dynamical analogies to the engineer.

This book deals with the analogies between electrical, mechanical rectilinear, mechanical rotational and acoustical systems. The subject matter is developed in stages from the simple element through to complex arrangements of multielement systems. As an aid in the establishment of these analogies a complete theme is depicted in each illustration.

The text assumes on the part of the reader a familiarity with the elements of alternating circuit theory and physics.

The author wishes to express his gratitude to his wife, Lorene E. Olson, for compilation and assistance in preparation and correction of the manuscript.

The author wishes to acknowledge the interest given by Mr. E. W. Engstrom, Research Director, in this project.

HARRY F. OLSON

JANUARY, 1943

CONTENTS

CHAPTER	PAGE
I. INTRODUCTION AND DEFINITIONS	
1.1 INTRODUCTION.....	1
1.2 DEFINITIONS.....	4
II. ELEMENTS	
2.1 INTRODUCTION.....	12
2.2 RESISTANCE.....	12
A. Electrical Resistance.....	12
B. Mechanical Rectilinear Resistance.....	13
C. Mechanical Rotational Resistance.....	13
D. Acoustical Resistance.....	13
2.3 INDUCTANCE, MASS, MOMENT OF INERTIA, INERTANCE.....	15
A. Inductance.....	15
B. Mass.....	15
C. Moment of Inertia.....	15
D. Inertance.....	16
2.4 ELECTRICAL CAPACITANCE, RECTILINEAL COMPLIANCE, ROTATIONAL COMPLIANCE, ACOUSTICAL CAPACITANCE.....	17
A. Electrical Capacitance.....	17
B. Rectilinear Compliance.....	17
C. Rotational Compliance.....	18
D. Acoustical Capacitance.....	18
2.5 REPRESENTATION OF ELECTRICAL, MECHANICAL RECTILINEAL, ME- CHANICAL ROTATIONAL AND ACOUSTICAL ELEMENTS.....	19
III. ELECTRICAL, MECHANICAL RECTILINEAL, MECHANICAL RO- TATIONAL, AND ACOUSTICAL SYSTEMS OF ONE DEGREE OF FREEDOM	
3.1 INTRODUCTION.....	25
3.2 DESCRIPTION OF SYSTEMS OF ONE DEGREE OF FREEDOM.....	25
3.3 KINETIC ENERGY.....	27
3.4 POTENTIAL ENERGY.....	28

CHAPTER		PAGE
3.5	DISSIPATION.....	29
3.6	EQUATIONS OF MOTION.....	30
3.7	RESONANT FREQUENCY.....	32
3.8	KIRCHHOFF'S LAW AND D'ALEMBERT'S PRINCIPLE.....	33
IV.	ELECTRICAL, MECHANICAL RECTILINEAL, MECHANICAL ROTATIONAL AND ACOUSTICAL SYSTEMS OF TWO AND THREE DEGREES OF FREEDOM	
4.1	INTRODUCTION.....	37
4.2	TWO DEGREES OF FREEDOM.....	37
4.3	KINETIC ENERGY.....	38
4.4	POTENTIAL ENERGY.....	39
4.5	DISSIPATION.....	39
4.6	EQUATIONS OF MOTION.....	40
4.7	THE ELECTRICAL SYSTEM.....	41
4.8	THE MECHANICAL RECTILINEAL SYSTEM.....	41
4.9	THE MECHANICAL ROTATIONAL SYSTEM.....	42
4.10	THE ACOUSTICAL SYSTEM.....	42
4.11	COMPARISON OF THE FOUR SYSTEMS.....	43
4.12	ELECTRICAL INDUCTIVE AND CAPACITIVE COUPLED SYSTEMS OF TWO DEGREES OF FREEDOM AND THE MECHANICAL RECTILINEAL, MECHANICAL ROTATIONAL AND ACOUSTICAL ANALOGIES.....	45
4.13	ELECTRICAL, MECHANICAL RECTILINEAL, MECHANICAL ROTATIONAL AND ACOUSTICAL SYSTEMS OF THREE DEGREES OF FREEDOM.....	48
V.	CORRECTIVE NETWORKS	
5.1	INTRODUCTION.....	52
5.2	TWO ELECTRICAL, MECHANICAL RECTILINEAL, MECHANICAL ROTATIONAL OR ACOUSTICAL IMPEDANCES IN PARALLEL.....	52
5.3	SHUNT CORRECTIVE NETWORKS.....	56
5.4	INDUCTANCE IN SHUNT WITH A LINE AND THE MECHANICAL RECTILINEAL, MECHANICAL ROTATIONAL AND ACOUSTICAL ANALOGIES....	58
5.5	ELECTRICAL CAPACITANCE IN SHUNT WITH A LINE AND THE MECHANICAL RECTILINEAL, MECHANICAL ROTATIONAL AND ACOUSTICAL ANALOGIES.....	60
5.6	INDUCTANCE AND ELECTRICAL CAPACITANCE IN SERIES, IN SHUNT WITH A LINE AND THE MECHANICAL RECTILINEAL, MECHANICAL ROTATIONAL AND ACOUSTICAL ANALOGIES.....	62
5.7	INDUCTANCE AND ELECTRICAL CAPACITANCE IN PARALLEL, IN SHUNT WITH A LINE AND THE MECHANICAL RECTILINEAL, MECHANICAL ROTATIONAL AND ACOUSTICAL ANALOGIES.....	64
5.8	ELECTRICAL RESISTANCE, INDUCTANCE AND ELECTRICAL CAPACITANCE IN SERIES, IN SHUNT WITH A LINE AND THE MECHANICAL RECTILINEAL, MECHANICAL ROTATIONAL AND ACOUSTICAL ANALOGIES....	67

CONTENTS

CHAPTER

ix
PAGE

5.9	ELECTRICAL RESISTANCE, INDUCTANCE AND ELECTRICAL CAPACITANCE IN PARALLEL, IN SHUNT WITH A LINE AND THE MECHANICAL RECTILINEAL, MECHANICAL ROTATIONAL AND ACOUSTICAL ANALOGIES.....	69
5.10	SERIES CORRECTIVE NETWORKS.....	71
5.11	INDUCTANCE IN SERIES WITH A LINE AND THE MECHANICAL RECTILINEAL, MECHANICAL ROTATIONAL AND ACOUSTICAL ANALOGIES....	72
5.12	ELECTRICAL CAPACITANCE IN SERIES WITH A LINE AND THE MECHANICAL RECTILINEAL, MECHANICAL ROTATIONAL AND ACOUSTICAL ANALOGIES.....	74
5.13	INDUCTANCE AND ELECTRICAL CAPACITANCE IN SERIES WITH A LINE AND THE MECHANICAL RECTILINEAL, MECHANICAL ROTATIONAL, AND ACOUSTICAL ANALOGIES.....	76
5.14	INDUCTANCE AND ELECTRICAL CAPACITANCE IN PARALLEL, IN SERIES WITH A LINE AND THE MECHANICAL RECTILINEAL, MECHANICAL ROTATIONAL AND ACOUSTICAL ANALOGIES.....	78
5.15	ELECTRICAL RESISTANCE, INDUCTANCE AND ELECTRICAL CAPACITANCE IN SERIES WITH A LINE AND THE MECHANICAL RECTILINEAL, MECHANICAL ROTATIONAL AND ACOUSTICAL ANALOGIES.....	80
5.16	ELECTRICAL RESISTANCE, INDUCTANCE AND ELECTRICAL CAPACITANCE IN PARALLEL, IN SERIES WITH A LINE AND THE MECHANICAL RECTILINEAL, MECHANICAL ROTATIONAL AND ACOUSTICAL ANALOGIES.....	83
5.17	RESISTANCE NETWORKS.....	85
5.18	ELECTRICAL RESISTANCE IN SERIES WITH A LINE AND THE MECHANICAL RECTILINEAL, MECHANICAL ROTATIONAL, AND ACOUSTICAL ANALOGIES.....	85
5.19	ELECTRICAL RESISTANCE IN SHUNT WITH A LINE AND THE MECHANICAL RECTILINEAL, MECHANICAL ROTATIONAL AND ACOUSTICAL ANALOGIES.....	86
5.20	"T" TYPE ELECTRICAL RESISTANCE NETWORK AND THE MECHANICAL RECTILINEAL, MECHANICAL ROTATIONAL AND ACOUSTICAL ANALOGIES.....	87
5.21	"π" TYPE ELECTRICAL RESISTANCE NETWORK AND THE MECHANICAL RECTILINEAL, MECHANICAL ROTATIONAL AND ACOUSTICAL ANALOGIES.....	87
5.22	ELECTRICAL, MECHANICAL RECTILINEAL, MECHANICAL ROTATIONAL AND ACOUSTICAL TRANSFORMERS.....	88

VI. WAVE FILTERS

6.1	INTRODUCTION.....	92
6.2	TYPES OF WAVE FILTERS.....	92
6.3	RESPONSE CHARACTERISTICS OF WAVE FILTERS.....	93
6.4	LOW PASS WAVE FILTERS.....	94
6.5	HIGH PASS WAVE FILTERS.....	95
6.6	BAND PASS WAVE FILTERS.....	97
6.7	BAND ELIMINATION WAVE FILTERS.....	101

VII. TRANSIENTS

7.1	INTRODUCTION	105
7.2	THE HEAVISIDE OPERATIONAL CALCULUS	106
7.3	TRANSIENT RESPONSE OF AN INDUCTANCE AND ELECTRICAL RESISTANCE IN SERIES AND THE MECHANICAL RECTILINEAL, MECHANICAL ROTATIONAL AND ACOUSTICAL ANALOGIES	107
7.4	TRANSIENT RESPONSE OF AN ELECTRICAL RESISTANCE AND ELECTRICAL CAPACITANCE IN SERIES AND THE MECHANICAL RECTILINEAL, MECHANICAL ROTATIONAL AND ACOUSTICAL ANALOGIES	111
7.5	TRANSIENT RESPONSE OF AN ELECTRICAL RESISTANCE, INDUCTANCE AND ELECTRICAL CAPACITANCE IN SERIES AND THE MECHANICAL RECTILINEAL, MECHANICAL ROTATIONAL AND ACOUSTICAL ANALOGIES	114
7.6	ARBITRARY FORCE	120

VIII. DRIVING SYSTEMS

8.1	INTRODUCTION	124
8.2	ELECTRODYNAMIC DRIVING SYSTEM	124
8.3	ELECTROMAGNETIC DRIVING SYSTEMS	126
	A. Unpolarized Armature Type	127
	B. Polarized Reed Armature Type	130
	C. Polarized Balanced Armature Type	134
8.4	ELECTROSTATIC DRIVING SYSTEM	138
8.5	MAGNETOSTRICTION DRIVING SYSTEM	141
8.6	PIEZOELECTRIC DRIVING SYSTEM	148

IX. GENERATING SYSTEMS

9.1	INTRODUCTION	153
9.2	ELECTRODYNAMIC GENERATING SYSTEM	153
9.3	ELECTROMAGNETIC GENERATING SYSTEMS	155
	A. Reed Armature Generating System	155
	B. Balanced Armature Generating System	157
9.4	ELECTROSTATIC GENERATING SYSTEM	158
9.5	MAGNETOSTRICTION GENERATING SYSTEM	162
9.6	PIEZOELECTRIC GENERATING SYSTEM	165

X. THEOREMS

10.1	INTRODUCTION	171
10.2	RECIPROCITY THEOREMS	171
	A. Electrical Reciprocity Theorem	171
	B. Mechanical Rectilinear Reciprocity Theorem	172
	C. Mechanical Rotational Reciprocity Theorem	173
	D. Acoustical Reciprocity Theorem	173

CONTENTS

CHAPTER	xi PAGE
E. Mechanical-Acoustical Reciprocity Theorem.....	175
F. Electrical-Mechanical Reciprocity Theorem.....	176
G. Electrical-Mechanical-Acoustical Reciprocity Theorem.....	177
H. Electrical-Mechanical-Acoustical-Mechanical-Electrical Reciprocity Theorem.....	177
I. Acoustical-Mechanical-Electrical-Mechanical-Acoustical Reciprocity Theorem.....	178
10.3 THEVENIN'S THEOREMS.....	178
A. Thevenin's Electrical Theorem.....	178
B. Thevenin's Mechanical Rectilinear Theorem.....	178
C. Thevenin's Mechanical Rotational Theorem.....	178
D. Thevenin's Acoustical Theorem.....	178
10.4 SUPERPOSITION THEOREM.....	179
XI. APPLICATIONS	
11.1 INTRODUCTION.....	180
11.2 AUTOMOBILE MUFFLER.....	180
11.3 ELECTRIC CLIPPER.....	182
11.4 DIRECT RADIATOR LOUD SPEAKER.....	183
11.5 ROTATIONAL VIBRATION DAMPER.....	184
11.6 MACHINE VIBRATION ISOLATOR.....	185
11.7 MECHANICAL REFRIGERATOR VIBRATION ISOLATOR.....	186
11.8 SHOCKPROOF INSTRUMENT MOUNTING.....	187
11.9 AUTOMOBILE SUSPENSION SYSTEM.....	188
INDEX.....	191

CHAPTER I

INTRODUCTION AND DEFINITIONS

1.1. Introduction

Analogies are useful when it is desired to compare an unfamiliar system with one that is better known. The relations and actions are more easily visualized, the mathematics more readily applied and the analytical solutions more readily obtained in the familiar system. Analogies make it possible to extend the line of reasoning into unexplored fields.

A large part of engineering analysis is concerned with vibrating systems. Although not generally so considered, the electrical circuit is the most common example and the most widely exploited vibrating system. The equations of electrical circuit theory may be based on Maxwell's dynamical theory in which the currents play the role of velocities. Expressions for the kinetic energy, potential energy and dissipation show that network equations are deducible from general dynamic equations. In other words, an electrical circuit may be considered to be a vibrating system. This immediately suggests analogies between electrical circuits and other dynamical systems, as for example, mechanical and acoustical vibrating systems.

The equations of motion of mechanical systems were developed a long time before any attention was given to equations for electrical circuits. For this reason, in the early days of electrical circuit theory, it was natural to explain the action in terms of mechanical phenomena. However, at the present time electrical circuit theory has been developed to a much higher state than the corresponding theory of mechanical systems. The number of engineers and scientists versed in electrical circuit theory is many times the number equally familiar with mechanical systems.

Almost any work involving mechanical or acoustical systems also includes electrical systems and electrical circuit theory. The acoustical

engineer is interested in sound reproduction or the conversion of electrical or mechanical energy into acoustical energy, the development of vibrating systems and the control of sound vibrations. This involves acoustical, electroacoustical, mechanoacoustical or electromechanoacoustical systems. The mechanical engineer is interested in the development of various mechanisms or vibrating systems involving masses, springs and friction.

Electrical circuit theory is the branch of electromagnetic theory which deals with electrical oscillations in linear electrical networks.¹ An electrical network is a connected set of separate circuits termed branches or meshes. A circuit may be defined as a physical entity in which varying magnitudes may be specified in terms of time and a single dimension.² The branches or meshes are composed of elements. Elements are the constituent parts of a circuit. Electrical elements are resistance, inductance and capacitance. Vibrations in one dimension occur in mechanical systems made up of mechanical elements, as for example, various assemblies of masses, springs and brakes. Acoustical systems in which the dimensions are small compared to the wavelength are vibrations in a single dimension.

The number of independent variables required to completely specify the motion of every part of a vibrating system is a measure of the number of degrees of freedom of the system. If only a single variable is needed the system is said to have a single degree of freedom. In an electrical circuit the number of degrees of freedom is equal to the number of independent closed meshes or circuits.

The use of complex notation has been applied extensively to electrical circuits. Of course, this operational method can be applied to any analytically similar system.

Mathematically the elements in an electrical network are the coefficients in the differential equations describing the network. When the electric circuit theory is based upon Maxwell's dynamics the network forms a dynamical system in which the currents play the role of velocities. In the same way the coefficients in the differential equations of

¹ The use of the terms "circuit" and "network" in the literature is not established. The term "circuit" is often used to designate a network with several branches.

² The term "single dimension" implies that the movement or variation occurs along a path. In a field problem there is variation in two or three dimensions.

a mechanical or acoustical system may be looked upon as mechanical or acoustical elements. Kirchhoff's electromotive force law plays the same role in setting up the electrical equations as D'Alembert's principle does in setting up the mechanical and acoustical equations. That is to say, every electrical, mechanical or acoustical system may be considered as a combination of electrical, mechanical or acoustical elements. Therefore, any mechanical or acoustical system may be reduced to an electrical network and the problem may be solved by electrical circuit theory.

In view of the tremendous amount of study which has been directed towards the solution of circuits, particularly electrical circuits, and the engineer's familiarity with electrical circuits, it is logical to apply this knowledge to the solution of vibration problems in other fields by the same theory as that used in the solution of electrical circuits.

In this book, the author has attempted to outline the essentials of dynamical analogies³ from the standpoint of the engineer or applied scientist. Differential equations are used to show the basis for the analogies between electrical, mechanical and acoustical systems. However, the text has been written and illustrated so that the derivations may be taken for granted. The principal objective in this book is the establishment of analogies between electrical, mechanical and acoustical systems so that any one familiar with electrical circuits will be able to analyze the action of vibrating systems.

³ The analogies as outlined in this book are formal ones due to the similarity of the differential equations and do not imply that there is any physical similarity between quantities occupying the same position in their respective equations. There is no claim that the analogies as outlined in this book are the only ones possible. For example, in the past, mechanical impedance has been defined by some authors as the ratio of pressure to velocity, ratio of force to displacement, and ratio of pressure to displacement. Hanle (*Wiss. Veroff a. d. Siemens-Konzern*, Vol. XI, No. I) and Firestone (*Jour. Acous. Soc. Amer.*, Vol. 4, No. 4, 1933) have proposed analogies in which mechanical impedance is defined as the ratio of velocity to force. Every analogy possesses certain advantages, particularly in the solution of certain specific problems. However, the analogies as defined in this book conform with the American Standard Acoustical Terminology—z24.1 of 1942; and the Standards of Electroacoustics, Institute of Radio Engineers. In addition, all communication, circuit, and electrical engineering books employing analogies to explain alternating current phenomena use analogies as defined in this book. Finally, analogies as defined in this book are universally employed in the technical and scientific journals. Therefore, it is only logical to conform with the recognized standards and preponderance of usage.

1.2. Definitions

A few of the terms ⁴ used in dynamical analogies will be defined in this section. Terms not listed below will be defined in subsequent sections.

Periodic Quantity.—A periodic quantity is an oscillating quantity the values of which recur for equal increments of the independent variable. If a periodic quantity y is a function of x , then y has the property that $y = f(x) = f(x + T)$, where T , a constant, is a period of y . The smallest positive value of T is the primitive period of y , generally called simply the period of y . In general a periodic function can be expanded into a series of the form.

$$y = f(x) = A_0 + A_1 \sin(\omega x + \alpha_1) + A_2 \sin(2\omega x + \alpha_2) + \dots,$$

where ω , a positive constant, equals 2π divided by the period T , and the A 's and α 's are constants which may be positive, negative, or zero. This is called a Fourier series.

Cycle.—One complete set of the recurrent values of a periodic quantity comprises a cycle.

Period.—The time required for one cycle of a periodic quantity is the period. The unit is the second.

Frequency.—The number of cycles occurring per unit of time, or which would occur per unit of time if all subsequent cycles were identical with the cycle under consideration, is the frequency. The frequency is the reciprocal of the period. The unit is the cycle per second.

Octave.—An octave is the interval between two frequencies having a ratio of two to one.

Fundamental Frequency.—A fundamental frequency is the lowest component frequency of a periodic quantity.

Harmonic.—A harmonic is a component of a periodic quantity which is an integral multiple of the fundamental frequency. For example, a component the frequency of which is twice the fundamental frequency is called the second harmonic.

Basic Frequency.—The basic frequency of a periodic quantity is that frequency which is considered to be the most important. In a driven

⁴ Approximately one-half of the definitions in this chapter are taken from the American Standards Association standards. The remainder, which have not been defined at this time by any standards group, are written to conform with the analogous existing standards.

system it would in general be the driving frequency while in most periodic waves it would correspond to the fundamental frequency.

Subharmonic.—A subharmonic is a component of a periodic quantity having a frequency which is an integral submultiple of the basic frequency.

Note: The term “subharmonic” is generally applied in the case of a driven system whose vibration has frequency components of lower frequency than the driving frequency.

Wave.—A wave is a propagated disturbance, usually a periodic quantity in an electrical, mechanical or acoustical system.

Wavelength.—The wavelength of a periodic wave in an isotropic medium is the perpendicular distance between two wave fronts in which the displacements have a phase difference of one complete cycle.

Abvolt.—An abvolt is the unit of electromotive force.

Instantaneous Electromotive Force.—The instantaneous electromotive force between two points is the total instantaneous electromotive force. The unit is the abvolt.

Effective Electromotive Force.—The effective electromotive force is the root mean square of the instantaneous electromotive force over a complete cycle between two points. The unit is the abvolt.

Maximum Electromotive Force.—The maximum electromotive force is the maximum absolute value of the instantaneous electromotive force during that cycle. The unit is the abvolt.

Peak Electromotive Force.—The peak electromotive force for any specified time interval is the maximum absolute value of the instantaneous electromotive force during that cycle. The unit is the abvolt.

Dyne.—A dyne is the unit of force or mechanomotive force.

Instantaneous Force (Instantaneous Mechanomotive Force).—The instantaneous force at a point is the total instantaneous force. The unit is the dyne.

Effective Force (Effective Mechanomotive Force).—The effective force is the root mean square of the instantaneous force over a complete cycle. The unit is the dyne.

Maximum Force (Maximum Mechanomotive Force).—The maximum force is the maximum absolute value of the instantaneous force during that cycle. The unit is the dyne.

Peak Force (Peak Mechanomotive Force).—The peak force for any specified interval is the maximum absolute value of the instantaneous force during that cycle. The unit is the dyne.

Dyne Centimeter.—A dyne centimeter is the unit of torque or rotatomotive force.

Instantaneous Torque (Instantaneous Rotatomotive Force).—The instantaneous torque at a point is the total instantaneous torque. The unit is the dyne centimeter.

Effective Torque (Effective Rotatomotive Force).—The effective torque is the root mean square of the instantaneous torque over a complete cycle. The unit is the dyne centimeter.

Maximum Torque (Maximum Rotatomotive Force).—The maximum torque is the maximum absolute value of the instantaneous torque during that cycle. The unit is the dyne centimeter.

Peak Torque (Peak Rotatomotive Force).—The peak torque for a specified interval is the maximum absolute value of the instantaneous torque during that cycle. The unit is the dyne centimeter.

Dyne per Square Centimeter.—A dyne per square centimeter is the unit of sound pressure or acoustomotive force.

Static Pressure.—The static pressure is the pressure that would exist in a medium with no sound waves present. The unit is the dyne per square centimeter.

Instantaneous Sound Pressure (Instantaneous Acoustomotive Force).—The instantaneous sound pressure at a point is the total instantaneous pressure at the point minus the static pressure. The unit is the dyne per square centimeter.

Effective Sound Pressure (Effective Acoustomotive Force).—The effective sound pressure at a point is the root mean square value of the instantaneous sound pressure over a complete cycle at the point. The unit is the dyne per square centimeter.

Maximum Sound Pressure (Maximum Acoustomotive Force).—The maximum sound pressure for any given cycle is the maximum absolute value of the instantaneous sound pressure during that cycle. The unit is the dyne per square centimeter.

Peak Sound Pressure (Peak Acoustomotive Force).—The peak sound pressure for any specified time interval is the maximum absolute value of the instantaneous sound pressure in that interval. The unit is the dyne per square centimeter.

Abampere.—An abampere is the unit of current.

Instantaneous Current.—The instantaneous current at a point is the total instantaneous current at that point. The unit is the abampere.

Effective Current.—The effective current at a point is the root mean square value of the instantaneous current over a complete cycle at that point. The unit is the abampere.

Maximum Current.—The maximum current for any given cycle is the maximum absolute value of the instantaneous current during that cycle. The unit is the abampere.

Peak Current.—The peak current for any specified time interval is the maximum absolute value of the instantaneous current in that interval. The unit is the abampere.

Centimeter per Second.—A centimeter per second is the unit of velocity.

Instantaneous Velocity.—The instantaneous velocity at a point is the total instantaneous velocity at that point. The unit is the centimeter per second.

Effective Velocity.—The effective velocity at a point is the root mean square value of the instantaneous velocity over a complete cycle at that point. The unit is the centimeter per second.

Maximum Velocity.—The maximum velocity for any given cycle is the maximum absolute value of the instantaneous velocity during that cycle. The unit is the centimeter per second.

Peak Velocity.—The peak velocity for any specified time interval is the maximum absolute value of the instantaneous velocity in that interval. The unit is the centimeter per second.

Radian per Second.—A radian per second is the unit of angular velocity.

Instantaneous Angular Velocity.—The instantaneous angular velocity at a point is the total instantaneous angular velocity at that point. The unit is the radian per second.

Effective Angular Velocity.—The effective angular velocity at a point is the root mean square value of the instantaneous angular velocity over a complete cycle at the point. The unit is the radian per second.

Maximum Angular Velocity.—The maximum angular velocity for any given cycle is the maximum absolute value of the instantaneous angular velocity during that cycle. The unit is the radian per second.

Peak Angular Velocity.—The peak angular velocity for any specified time interval is the maximum absolute value of the instantaneous angular velocity in that interval. The unit is the radian per second.

Cubic Centimeter per Second.—A cubic centimeter is the unit of volume current.

Instantaneous Volume Current.—The instantaneous volume current at a point is the total instantaneous volume current at that point. The unit is the cubic centimeter per second.

Effective Volume Current.—The effective volume current at a point is the root mean square value of the instantaneous volume current over a complete cycle at that point. The unit is the cubic centimeter per second.

Maximum Volume Current.—The maximum volume current for any given cycle is the maximum absolute value of the instantaneous volume current during that cycle. The unit is the cubic centimeter per second.

Peak Volume Current.—The peak volume current for any specified time interval is the maximum absolute value of the instantaneous volume current in that interval. The unit is the cubic centimeter per second.

Electrical Impedance.—Electrical impedance is the complex quotient of the alternating electromotive force applied to the system by the resulting current. The unit is the abohm.

Electrical Resistance.—Electrical resistance is the real part of the electrical impedance. This is the part responsible for the dissipation of energy. The unit is the abohm.

Electrical Reactance.—Electrical reactance is the imaginary part of the electrical impedance. The unit is the abohm.

Inductance.—Inductance in an electrical system is that coefficient which, when multiplied by 2π times the frequency, gives the positive imaginary part of the electrical impedance. The unit is the abhenry.

Electrical Capacitance.—Electrical capacitance in an electrical system is that coefficient which, when multiplied by 2π times the frequency, is the reciprocal of the negative imaginary part of the electrical impedance. The unit is the abfarad.

Mechanical Rectilinear Impedance⁵ (Mechanical Impedance).—Mechanical rectilinear impedance is the complex quotient of the alternating force applied to the system by the resulting linear velocity in the direction of the force at its point of application. The unit is the mechanical ohm.

⁵The word "mechanical" is ordinarily used as a modifier to designate a mechanical system with rectilinear displacements and the word "rotational" is ordinarily used as a modifier to designate a mechanical system with rotational displacements. To avoid ambiguity in this book, where both systems are considered concurrently, the words "mechanical rectilinear" are used as modifiers to designate a mechanical system with rectilinear displacements and the words "mechanical rotational" are used as modifiers to designate a mechanical system with rotational displacements.

Mechanical Rectilinear Resistance (Mechanical Resistance).—Mechanical rectilinear resistance is the real part of the mechanical rectilinear impedance. This is the part responsible for the dissipation of energy. The unit is the mechanical ohm.

Mechanical Rectilinear Reactance (Mechanical Reactance).—Mechanical rectilinear reactance is the imaginary part of the mechanical rectilinear impedance. The unit is the mechanical ohm.

Mass.—Mass in a mechanical system is that coefficient which, when multiplied by 2π times the frequency, gives the positive imaginary part of the mechanical rectilinear impedance. The unit is the gram.

Compliance.—Compliance in a mechanical system is that coefficient which, when multiplied by 2π times the frequency, is the reciprocal of the negative imaginary part of the mechanical rectilinear impedance. The unit is the centimeter per dyne.

Mechanical Rotational Impedance ⁶ (*Rotational Impedance*).—Mechanical rotational impedance is the complex quotient of the alternating torque applied to the system by the resulting angular velocity in the direction of the torque at its point of application. The unit is the rotational ohm.

Mechanical Rotational Resistance (Rotational Resistance).—Mechanical rotational resistance is the real part of the mechanical rotational impedance. This is the part responsible for the dissipation of energy. The unit is the rotational ohm.

Mechanical Rotational Reactance (Rotational Reactance).—Mechanical rotational reactance is the imaginary part of the mechanical rotational impedance. The unit is the rotational ohm.

Moment of Inertia.—Moment of inertia in a mechanical rotational system is that coefficient which, when multiplied by 2π times the frequency, gives the positive imaginary part of the mechanical rotational impedance. The unit is the gram centimeter to the second power.

Rotational Compliance.—Rotational compliance in a mechanical rotational system is that coefficient which, when multiplied by 2π times the frequency, is the reciprocal of the negative imaginary part of the mechanical rotational impedance. The unit is the radian per centimeter per dyne.

Acoustical Impedance.—Acoustical impedance is the complex quotient of the pressure applied to the system by the resulting volume current. The unit is the acoustical ohm.

⁶ See footnote 5, page 8.

Acoustical Resistance.—Acoustical resistance is the real part of the acoustical impedance. This is the part responsible for the dissipation of energy. The unit is the acoustical ohm.

Acoustical Reactance.—Acoustical reactance is the imaginary part of the acoustical impedance. The unit is the acoustical ohm.

Inertance.—Inertance in an acoustical system is that coefficient which, when multiplied by 2π times the frequency, gives the positive imaginary part of the acoustical impedance. The unit is the gram per centimeter to the fourth power.

Acoustical Capacitance.—Acoustical capacitance in an acoustical system is that coefficient which, when multiplied by 2π times the frequency, is the reciprocal negative imaginary part of the acoustical impedance. The unit is the centimeter to the fifth power per dyne.

*Element.*⁷—An element or circuit parameter in an electrical system defines a distinct activity in its part of the circuit. In the same way, an element in a mechanical rectilinear, mechanical rotational or acoustical system defines a distinct activity in its part of the system. The elements in an electrical circuit are electrical resistance, inductance and electrical capacitance. The elements in a mechanical rectilinear system are mechanical rectilinear resistance, mass and compliance. The elements in a mechanical rotational system are mechanical rotational resistance, moment of inertia, and rotational compliance. The elements in an acoustical system are acoustical resistance, inertance and acoustical capacitance.

Electrical System.—An electrical system is a system adapted for the transmission of electrical currents consisting of one or all of the electrical elements: electrical resistance, inductance and electrical capacitance.

Mechanical Rectilinear System.—A mechanical rectilinear system is a system adapted for the transmission of linear vibrations consisting of one or all of the following mechanical rectilinear elements: mechanical rectilinear resistance, mass and compliance.

Mechanical Rotational System.—A mechanical rotational system is a system adapted for the transmission of rotational vibrations consisting of one or all of the following mechanical rotational elements: mechanical rotational resistance, moment of inertia and rotational compliance.

Acoustical System.—An acoustical system is a system adapted for the transmission of sound consisting of one or all of the following acoustical elements: acoustical resistance, inertance and acoustical capacitance.

⁷ Elements are defined and described in Chapter II.

Transducer.—A transducer is a device actuated by power from one system and supplying power in the same or any other form to a second system. Either of these systems may be electrical, mechanical or acoustical.

Transmission.—Transmission in a system refers to the transmission of power, voltage, current, force, velocity, torque, angular velocity, pressure or volume current.

Transmission Loss (or Gain).—The transmission loss due to a system joining a load having a given electrical, mechanical rectilinear, mechanical rotational or acoustical impedance and a source having a given electrical, mechanical rectilinear, mechanical rotational or acoustical impedance and a given electromotive force, force, torque or pressure is expressed by the logarithm of the ratio of the power delivered to the load to the power delivered to the load under some reference condition. For a loss the reference power is greater. For a gain the reference power is smaller.

Decibel.—The abbreviation db is used for the decibel. The bel is the fundamental division of a logarithmic scale expressing the ratio of two amounts of power, the number of bels denoting such a ratio being the logarithm to the base ten of this ratio. The decibel is one-tenth of a bel. For example, with P_1 and P_2 designating two amounts of power and n the number of decibels denoting their ratio

$$n = 10 \log_{10} \frac{P_1}{P_2}, \text{ decibels}$$

When the conditions are such that ratios of voltages or ratios of currents (or analogous quantities such as forces or velocities, torques or angular velocities, pressures or volume currents) are the square roots of the corresponding power ratios, the number of decibels by which the corresponding powers differ is expressed by the following formulas:

$$n = 20 \log_{10} \frac{i_1}{i_2}, \text{ decibels}$$

$$n = 20 \log_{10} \frac{e_1}{e_2}, \text{ decibels}$$

where i_1/i_2 and e_1/e_2 are the given current and voltage ratios respectively.

CHAPTER II

ELEMENTS

2.1. Introduction

An element or circuit parameter in an electrical system defines a distinct activity in its part of the circuit. In an electrical system these elements are resistance, inductance and capacitance. They are distinguished from the devices; resistor, inductor and capacitor. A resistor, inductor and capacitor idealized to have only resistance, inductance and capacitance is a circuit element. As indicated in the preceding chapter, the study of mechanical and acoustical systems is facilitated by the introduction of elements analogous to the elements of an electric circuit. In this procedure, the first step is to develop the elements in these vibrating systems. It is the purpose of this chapter to define and describe electrical, mechanical rectilinear, mechanical rotational and acoustical elements.¹

2.2. Resistance

A. *Electrical Resistance.*—Electrical energy is changed into heat by the passage of an electrical current through a resistance. Energy is lost by the system when a charge q is driven through a resistance by a voltage e . Resistance is the circuit element which causes dissipation.

Electrical resistance r_E , in abohms, is defined as

$$r_E = \frac{e}{i} \qquad 2.1$$

where e = voltage across the resistance, in abvolts, and
 i = current through the resistance, in abamperes.

Equation 2.1 states that the electromotive force across an electrical resistance is proportional to the electrical resistance and the current.

¹ See footnote 5, page 8.

B. Mechanical Rectilinear Resistance.—Mechanical rectilinear energy is changed into heat by a rectilinear motion which is opposed by linear resistance (friction). In a mechanical system dissipation is due to friction. Energy is lost by the system when a mechanical rectilinear resistance is displaced a distance x by a force f_M .

Mechanical rectilinear resistance (termed mechanical resistance) r_M , in mechanical ohms, is defined as

$$r_M = \frac{f_M}{u} \quad 2.2$$

where f_M = applied mechanical force, in dynes, and

u = velocity at the point of application of the force, in centimeters per second.

Equation 2.2 states that the driving force applied to a mechanical rectilinear resistance is proportional to the mechanical rectilinear resistance and the linear velocity.

C. Mechanical Rotational Resistance.—Mechanical rotational energy is changed into heat by a rotational motion which is opposed by a rotational resistance (rotational friction). Energy is lost by the system when a mechanical rotational resistance is displaced by an angle ϕ by a torque f_R .

Mechanical rotational resistance (termed rotational resistance) r_R , in rotational ohms, is defined as

$$r_R = \frac{f_R}{\theta} \quad 2.3$$

where f_R = applied torque, in dyne centimeters, and

θ = angular velocity at the point of application about the axis, in radians per second.

Equation 2.3 states that the driving torque applied to a mechanical rotational resistance is proportional to the mechanical rotational resistance and the angular velocity.

D. Acoustical Resistance.—In an acoustical system dissipation may be due to the fluid resistance or radiation resistance. At this point the former type of acoustical resistance will be considered. Acoustical energy is changed into heat by the passage of a fluid through an acoustical resistance. The resistance is due to viscosity. Energy is lost by the system when a volume X is driven through an acoustical resistance by a pressure p .

Acoustical resistance r_A , in acoustical ohms, is defined as

$$r_A = \frac{p}{U} \quad 2.4$$

where p = pressure, in dynes per square centimeter, and
 U = volume current, in cubic centimeters per second.

Equation 2.4 states that the driving pressure applied to an acoustical resistance is proportional to the acoustical resistance and the volume current.

The transmission of sound waves or direct currents of air through small constrictions is primarily governed by acoustical resistance due to viscosity. A tube of small diameter, a narrow slit, and metal, or cotton or silk cloth are a few examples of systems which exhibit acoustical resistance. There is also, in addition to the resistive component, a reactive component. However, the ratio of the two components is a function of the dimensions. This is illustrated by the following equation for the acoustic impedance ² of a narrow slit.

$$z_A = \frac{12\mu w}{d^3 l} + j \frac{6\rho w \omega}{5ld} \quad 2.5$$

where μ = viscosity coefficient, 1.86×10^{-4} for air, density, in grams per cubic centimeter,

d = thickness of the slit normal to the direction of flow, in centimeters,

l = width of the slit normal to the direction of flow, in centimeters,

w = length of the slit in the direction of flow, in centimeters,

$\omega = 2\pi f$, and

f = frequency in cycles per second.

Any ratio of acoustical resistance to acoustical reactance can be obtained by a suitable value of d . Then the value of acoustical resistance can be obtained by an appropriate value of w and l . The same expedient may be employed in the case of any acoustical resistance in which the resistance is due to viscosity.

²Olson, "Elements of Acoustical Engineering," D. Van Nostrand Co., New York, 1940.

2.3. Inductance, Mass, Moment of Inertia, Inertance

A. *Inductance*.—Electromagnetic energy is associated with inductance. Electromagnetic energy increases as the current in the inductance increases. It decreases when the current decreases. It remains constant when the current in the inductance is a constant. Inductance is the electrical circuit element which opposes a change in current. Inductance L , in abhenries, is defined as

$$e = L \frac{di}{dt} \quad 2.6$$

where e = electromotive or driving force, in abvolts, and
 di/dt = rate of change of current, in abamperes per second.

Equation 2.6 states that the electromotive force across an inductance is proportional to the inductance and the rate of change of current.

B. *Mass*.—Mechanical rectilinear inertial energy is associated with mass in the mechanical rectilinear system. Mechanical rectilinear energy increases as the linear velocity of a mass increases, that is, during linear acceleration. It decreases when the velocity decreases. It remains constant when the velocity is a constant. Mass is the mechanical element which opposes a change of velocity. Mass m , in grams, is defined as

$$f_M = m \frac{du}{dt} \quad 2.7$$

where du/dt = acceleration, in centimeters per second per second, and
 f_M = driving force, in dynes.

Equation 2.7 states that the driving force applied to the mass is proportional to the mass and the rate of change of linear velocity.

C. *Moment of Inertia*.—Mechanical rotational inertial energy is associated with moment of inertia in the mechanical rotational system. Mechanical rotational energy increases as the angular velocity of a moment of inertia increases, that is, during angular acceleration. It decreases when the angular velocity decreases. It remains a constant when the angular velocity is a constant. Moment of inertia I , in gram (centimeter)², is given by

$$f_R = I \frac{d\theta}{dt} \quad 2.8$$

where $d\theta/dt$ = angular acceleration, in radians per second per second,
and

f_R = torque, in dyne centimeters.

Equation 2.8 states that the driving torque applied to the moment of inertia is proportional to the moment of inertia and the rate of change of angular velocity.

D. *Inertance*.—Acoustical inertial energy is associated with inertance in the acoustical system. Acoustical energy increases as the volume current of an inertance increases. It decreases when the volume current decreases. It remains constant when the volume current is a constant. Inertance is the acoustical element that opposes a change in volume current. Inertance M , in grams per (centimeter)⁴, is defined as

$$p = M \frac{dU}{dt} \quad 2.9$$

where M = inertance, in grams per (centimeter)⁴,

dU/dt = rate of change of volume current, in cubic centimeters per second per second, and

p = driving pressure, in dynes per square centimeter.

Equation 2.9 states that the driving pressure applied to an inertance is proportional to the inertance and the rate of change of volume current.

Inertance³ may be expressed as

$$M = \frac{m}{S^2} \quad 2.10$$

where m = mass, in grams,

S = cross sectional area in square centimeters, over which the driving pressure acts to drive the mass.

The inertance of a circular tube is

$$M = \frac{\rho l}{\pi R^2} \quad 2.11$$

where R = radius of the tube, in centimeters,

l = effective length of the tube, that is, length plus end correction, in centimeters, and

ρ = density of the medium in the tube, in grams per cubic centimeter.

³ Olson, "Elements of Acoustical Engineering," D. Van Nostrand Co., New York, 1940.

2.4. Electrical Capacitance, Rectilinear Compliance, Rotational Compliance, Acoustical Capacitance

A. *Electrical Capacitance*.—Electrostatic energy is associated with the separation of positive and negative charges as in the case of the charges on the two plates of an electrical capacitance. Electrostatic energy increases as the charges of opposite polarity are separated. It is constant and stored when the charges remain unchanged. It decreases as the charges are brought together and the electrostatic energy released. Electrical capacitance is the electrical circuit element which opposes a change in voltage. Electrical capacitance C_E , in abfarads, is defined as

$$i = C_E \frac{de}{dt} \quad 2.12$$

Equation 2.12 may be written

$$e = \frac{1}{C_E} \int i dt = \frac{q}{C_E} \quad 2.13$$

where q = charge on electrical capacitance, in abcoulombs, and
 e = electromotive force, in abvolts.

Equation 2.13 states that the charge on an electrical capacitance is proportional to the electrical capacitance and the applied electromotive force.

B. *Rectilinear Compliance*.—Mechanical rectilinear potential energy is associated with the compression of a spring or compliant element. Mechanical energy increases as the spring is compressed. It decreases as the spring is allowed to expand. It is a constant, and is stored, when the spring remains immovably compressed. Rectilinear compliance is the mechanical element which opposes a change in the applied force. Rectilinear compliance C_M (termed compliance) in centimeters per dyne, is defined as

$$f_M = \frac{x}{C_M} \quad 2.14$$

where x = displacement, in centimeters, and
 f_M = applied force, in dynes

Equation 2.14 states that the linear displacement of a compliance is proportional to the compliance and the applied force.

Stiffness is the reciprocal of compliance.

C. *Rotational Compliance*.—Mechanical rotational potential energy is associated with the twisting of a spring or compliant element. Mechanical energy increases as the spring is twisted. It decreases as the spring is allowed to unwind. It is constant, and is stored when the spring remains immovably twisted. Rotational compliance is the mechanical element which opposes a change in the applied torque. Rotational compliance C_R , in radians per centimeter per dyne, is defined as

$$f_R = \frac{\phi}{C_R} \quad 2.15$$

where ϕ = angular displacement, in radians, and
 f_R = applied torque, in dyne centimeters.

Equation 2.15 states that the rotational displacement of the rotational compliance is proportional to the rotational compliance and the applied force.

D. *Acoustical Capacitance*.—Acoustical potential energy is associated with the compression of a fluid or gas. Acoustical energy increases as the gas is compressed. It decreases as the gas is allowed to expand. It is constant, and is stored when the gas remains immovably compressed. Acoustical capacitance is the acoustic element which opposes a change in the applied pressure. The pressure,⁴ in dynes per square centimeter, in terms of the condensation, is

$$p = c^2 \rho s \quad 2.16$$

where c = velocity, in centimeters per second,
 ρ = density, in grams per cubic centimeter, and
 s = condensation, defined in equation 2.17.

The condensation in a volume V due to a change in volume from V to V' is

$$s = \frac{V - V'}{V} \quad 2.17$$

⁴Olson, "Elements of Acoustical Engineering," p. 9, D. Van Nostrand Co., New York, 1940.

The change in volume $V - V'$, in cubic centimeters, is equal to the volume displacement, in cubic centimeters.

$$V - V' = X \quad 2.18$$

where X = volume displacement, in cubic centimeters.

From equations 2.16, 2.17, and 2.18 the pressure is

$$p = \frac{\rho c^2}{V} X \quad 2.19$$

Acoustical capacitance C_A is defined as

$$p = \frac{X}{C_A} \quad 2.20$$

where p = sound pressure in dynes per square centimeter, and
 X = volume displacement, in cubic centimeters.

Equation 2.20 states the volume displacement in an acoustical capacitance is proportional to the pressure and the acoustical capacitance.

From equations 2.19 and 2.20 the acoustical capacitance of a volume is

$$C_A = \frac{V}{\rho c^2} \quad 2.21$$

where V = volume, in cubic centimeters.

2.5. Representation of Electrical, Mechanical Rectilinear, Mechanical Rotational and Acoustical Elements

Electrical, mechanical rectilinear, mechanical rotational and acoustical elements have been defined in the preceding sections. Fig. 2.1 illustrates schematically the four elements in each of the four systems.

The electrical elements, electrical resistance, inductance and electrical capacitance are represented by the conventional symbols.

Mechanical rectilinear resistance is represented by sliding friction which causes dissipation. Mechanical rotational resistance is represented by a wheel with a sliding friction brake which causes dissipation. Acoustical resistance is represented by narrow slits which causes dissipation due to viscosity when fluid is forced through the slits. These elements are analogous to electrical resistance in the electrical system.

Inertia in the mechanical rectilinear system is represented by a mass. Moment of inertia in the mechanical rotational system is represented by a flywheel. Inertance in the acoustical system is represented as the fluid contained in a tube in which all the particles move with the same phase when actuated by a force due to pressure. These elements are analogous to inductance in the electrical system.

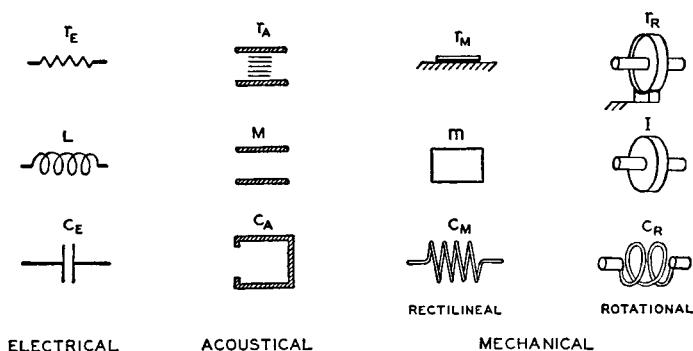

FIG. 2.1. Graphical representation of the three basic elements in electrical, mechanical rectilinear, mechanical rotational and acoustical systems.

r_E = electrical re- sistance	r_A = acoustical re- sistance	r_M = mechanical rectilinear resistance	r_R = mechanical ro- tational re- sistance
L = inductance	M = inertance	m = mass	I = moment of in- ertia
C_E = electrical ca- pacitance	C_A = acoustical ca- pacitance	C_M = compliance	C_R = rotational compliance

Compliance in the mechanical rectilinear system is represented as a spring. Rotational compliance in the mechanical rotational system is represented as a spring. Acoustical capacitance in the acoustical system is represented as a volume which acts as a stiffness or spring element. These elements are analogous to electrical capacitance in the electrical system.

In the preceding discussion of electrical, mechanical rectilinear, mechanical rotational and acoustical systems it was observed that the four systems are analogous. As pointed out in the introduction, using the dynamical concept for flow of electrical currents in electrical circuits the fundamental laws are of the same nature as those which govern the dynamics of a moving body. In general, the three fundamental dimen-

TABLE 2.1

Electrical		Mechanical Rectilinear		Mechanical Rotational		Acoustical	
Quantity	Symbol	Quantity	Symbol	Quantity	Symbol	Quantity	Symbol
Self-Inductance	L	Mass	m	Moment of Inertia	I	Inertance	M
Electrical Charge	q	Linear Displacement	x	Angular Displacement	ϕ	Volume Displacement	X
Time	t	Time	t	Time	t	Time	t

TABLE 2.2

Electrical		Mechanical Rectilinear			Mechanical Rotational			Acoustical		
Quantity	Symbol	Dimension	Quantity	Symbol	Quantity	Symbol	Dimension	Quantity	Symbol	Dimension
Current	i	qt^{-1}	Linear Velocity	\dot{x} or v	Angular Velocity	$\dot{\phi}$ or θ	ϕt^{-1}	Volume Current	\dot{X} or U	Xt^{-1}
Electromotive Force	e	Lqt^{-2}	Force	f_M	Torque	f_R	$I\phi t^{-2}$	Pressure	p	MXt^{-2}
Electrical Resistance	r_E	Lt^{-1}	Mechanical Resistance	r_M	Rotational Resistance	r_R	It^{-1}	Acoustical Resistance	r_A	Mt^{-1}
Electrical Capacitance	C_E	$L^{-1}t^2$	Compliance	C_M	Rotational Compliance	C_R	$I^{-1}t^2$	Acoustical Capacitance	C_A	$M^{-1}t^2$
Energy	W_E	Lq^2t^{-2}	Energy	W_M	Energy	W_R	$I\phi^2t^{-2}$	Energy	W_A	MX^2t^{-2}
Power	P_E	Lq^2t^{-3}	Power	P_M	Power	P_R	$I\phi^2t^{-3}$	Power	P_A	MX^2t^{-3}

TABLE 2.3

Electrical				Mechanical Rectilinear			
Quantity	Unit	Sym- bol	Dimension	Quantity	Unit	Sym- bol	Dimension
Electromotive Force	Volts $\times 10^8$	e	$M^{1/2}L^{3/2}T^{-2}$	Force	Dynes	f_M	MLT^{-2}
Charge or Quantity	Coulombs $\times 10^{-1}$	q	$M^{1/2}L^{1/2}$	Linear Displacement	Centimeters	x	L
Current	Amperes $\times 10^{-1}$	i	$M^{1/2}L^{1/2}T^{-1}$	Linear Velocity	Centimeters per Second	\dot{x} or v	LT^{-1}
Electrical Impedance	Ohms $\times 10^9$	z_E	LT^{-1}	Mechanical Impedance	Mechanical Ohms	z_M	MT^{-1}
Electrical Resistance	Ohms $\times 10^9$	r_E	LT^{-1}	Mechanical Resistance	Mechanical Ohms	r_M	MT^{-1}
Electrical Reactance	Ohms $\times 10^9$	x_E	LT^{-1}	Mechanical Reactance	Mechanical Ohms	x_M	MT^{-1}
Inductance	Henries $\times 10^9$	L	L	Mass	Grams	m	M
Electrical Capacitance	Farads $\times 10^{-9}$	C_E	$L^{-1}T^2$	Compliance	Centimeters per Dyne	C_M	$M^{-1}T^2$
Power	Ergs per Second	P_E	ML^2T^{-3}	Power	Ergs per Second	P_M	ML^2T^{-3}

TABLE 2.3—Continued

Mechanical Rotational				Acoustical			
Quantity	Unit	Sym- bol	Dimension	Quantity	Unit	Sym- bol	Dimension
Torque	Dyne Centimeter	f_R	ML^2T^{-2}	Pressure	Dynes per Square Centimeter	p	$ML^{-1}T^{-2}$
Angular Displacement	Radians	ϕ	1	Volume Displacement	Cubic Centimeters	X	L^3
Angular Velocity	Radians per Second	$\dot{\phi}$ or θ	T^{-1}	Volume Current	Cubic Centimeters per Second	\dot{X} or U	L^3T^{-1}
Rotational Impedance	Rotational Ohms	z_R	ML^2T^{-1}	Acoustical Impedance	Acoustical Ohms	z_A	$ML^{-4}T^{-1}$
Rotational Resistance	Rotational Ohms	r_R	ML^2T^{-1}	Acoustical Resistance	Acoustical Ohms	r_A	$ML^{-4}T^{-1}$
Rotational Reactance	Rotational Ohms	x_R	ML^2T^{-1}	Acoustical Reactance	Acoustical Ohms	x_A	$ML^{-4}T^{-1}$
Moment of Inertia	(Gram) (Centimeter) ²	I	ML^2	Inertance	Grams per (Centimeter) ⁴	M	ML^{-4}
Rotational Compliance	Radians per Dyne per Centimeter	C_R	$M^{-1}L^{-2}T^2$	Acoustical Capacitance	(Centimeter) ⁵ per Dyne	C_A	$M^{-1}L^4T^2$
Power	Ergs per Second	P_R	ML^2T^{-3}	Power	Ergs per Second	P_A	ML^2T^{-3}

sions are mass, length, and time. These quantities are directly connected to the mechanical rectilinear system. Other quantities in the mechanical rectilinear system may be derived in terms of these dimensions. In terms of analogies the dimensions in the electrical circuit corresponding to length, mass and time in the mechanical rectilinear system are charge, self-inductance, and time. The corresponding analogous dimensions in the rotational mechanical system are angular displacement moment of inertia, and time. The corresponding analogous dimensions in the acoustical system are volume displacement, inertance and time. The above mentioned fundamental dimensions in each of the four systems are shown in tabular form in Table 2.1. Other quantities in each of the four systems may be expressed in terms of the dimensions of Table 2.1.⁵ A few of the most important quantities have been tabulated in Table 2.2. Tables 2.1 and 2.2 depict analogous quantities in each of the four systems. Further, it shows that the four systems are dynamically analogous.

The dimensions given in Table 2.1 should not be confused with the classical dimensions of electrical, mechanical and acoustical systems given in Table 2.3. Table 2.3 uses mass M , length L and time T . In the case of the electrical units dielectric and permeability constants are assumed to be dimensionless.

⁵ The Tables 2.1, 2.2 and 2.3 deviate from the procedure outlined in footnote 5, page 8, and list the standard modifiers for all four systems.

CHAPTER III

ELECTRICAL, MECHANICAL RECTILINEAL, MECHANICAL ROTATIONAL, AND ACOUSTICAL SYSTEMS OF ONE DEGREE OF FREEDOM

3.1. Introduction

In the preceding sections the fundamental elements in each of the four systems have been defined. From these definitions it is evident that friction, mass, and compliance govern the movements of physical bodies in the same manner that resistance, inductance and capacitance govern the movement of electricity. In any dynamical system there are two distinct problems; namely, the derivation of the differential equation from the statement of the problem and the physical laws, and the solution of the differential equation. It is the purpose of this chapter to establish and solve the differential equations for electrical, mechanical rectilinear, mechanical rotational and acoustical systems of one degree of freedom. These equations will show that the coefficients in the differential equation of the electrical system are elements in the electrical circuit. In the same way the coefficients in the differential equations of the mechanical rectilinear, mechanical rotational and acoustical systems may be looked upon as mechanical rectilinear, mechanical rotational or acoustical elements. In other words, a consideration of the four systems of a single degree of freedom provides another means of establishing the analogies between electrical, mechanical rectilinear, mechanical rotational and acoustical systems.

3.2. Description of Systems of One Degree of Freedom

An electrical, mechanical rectilinear, mechanical rotational, and acoustical system of one degree of freedom is shown in Fig. 3.1. In one degree of freedom the activity in every element of the system may be expressed in terms of one variable. In the electrical system an electromotive force ϵ acts upon an inductance L , an electrical resistance r_E and an electrical

capacitance C_E connected in series. In the mechanical rectilinear system a driving force f_M acts upon a particle of mass m fastened to a spring or compliance C_M and sliding upon a plate with a frictional force which is proportional to the velocity and designated as the mechanical rectilinear resistance r_M . In the mechanical rotational system a driving torque f_R acts upon a flywheel of moment of inertia I connected to a spring or rotational compliance C_R and the periphery of the wheel sliding against a brake with a frictional force which is proportional to the velocity and designated as the mechanical rotational resistance r_R . In

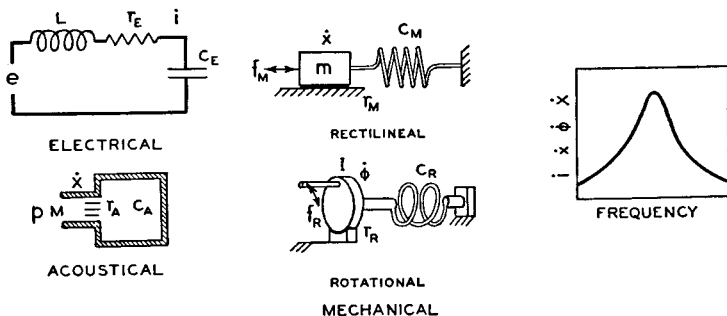

FIG. 3.1. Electrical, mechanical rectilinear, mechanical rotational and acoustical systems of one degree of freedom and the current, velocity, angular velocity and volume current response characteristics.

the acoustical system an impinging sound wave of pressure p acts upon an inertance M and an acoustical resistance r_A comprising the air in the tubular opening which is connected to the volume or acoustical capacitance C_A . The acoustical resistance r_A is due to viscosity.

The principle of the conservation of energy forms one of the basic theorems in most sciences. The principle of conservation of energy states that the total store of energy of all forms remains a constant if the system is isolated so that it neither receives nor gives out energy; in case of transfer of energy the total gain or loss from the system is equal to the loss or gain outside the system. In the electrical, mechanical rectilinear, mechanical rotational, and acoustical systems energy will be confined to three forms; namely, kinetic, potential and heat energy. Kinetic energy of a system is that possessed by virtue of its velocity. Potential energy of a system is that possessed by virtue of its configuration or deformation. Heat is a transient form of energy. In the four

systems; electrical, mechanical rectilinear, mechanical rotational, and acoustical energy is transformed into heat in the dissipative part of the system. The heat energy is carried away either by conduction or radiation. The sum of the kinetic, potential, and heat energy during an interval of time is, by the principle of conservation of energy, equal to the energy delivered to the system during that interval.

3.3. Kinetic Energy

The kinetic energy T_{KE} stored in the magnetic field of the electrical circuit is

$$T_{KE} = \frac{1}{2}Li^2 \quad 3.1$$

where L = inductance, in abhenries, and

i = current through the inductance L , in abamperes.

The kinetic energy T_{KM} stored in the mass of the mechanical rectilinear system is

$$T_{KM} = \frac{1}{2}m\dot{x}^2 \quad 3.2$$

where m = mass, in grams, and

\dot{x} = velocity of the mass m , in centimeters per second.

The kinetic energy T_{KR} stored in the moment of inertia of the mechanical rotational system is

$$T_{KR} = \frac{1}{2}I\dot{\phi}^2 \quad 3.3$$

where I = moment of inertia, in gram (centimeter)² and

$\dot{\phi}$ = angular velocity of I , in radians per second.

The kinetic energy T_{KA} stored in the inertance of the acoustical system is

$$T_{KA} = \frac{1}{2}M\dot{X}^2 \quad 3.4$$

where $M = m/S^2$, the inertance, in grams per (centimeter)⁴,

m = mass of air in the opening, in grams,

S = cross-sectional area of the opening, in square centimeters,

$\dot{X} = S\dot{x}$ = volume current, in cubic centimeters per second,

\dot{x} = velocity of the air particles in the opening, in centimeters per second.

It is assumed that all the air particles in the opening move with the same phase.

3.4. Potential Energy

The potential energy V_{PE} stored in the electrical capacitance of the electrical circuit is

$$V_{PE} = \frac{1}{2} \frac{q^2}{C_E} \quad 3.5$$

where C_E = capacitance, in abfarads, and
 q = charge on the capacitance, in abcoulombs.

The potential energy V_{PM} stored in the compliance or spring of the mechanical rectilinear system is

$$V_{PM} = \frac{1}{2} \frac{x^2}{C_M} \quad 3.6$$

where $C_M = 1/s$ = compliance of the spring, in centimeters per dyne,
 s = stiffness of the spring, in dynes per centimeter, and
 x = displacement, in centimeters.

The potential energy V_{PR} stored in the rotational compliance or spring of the mechanical rotational system is

$$V_{PR} = \frac{1}{2} \frac{\phi^2}{C_R} \quad 3.7$$

where C_R = rotational compliance of the spring, in radians per dyne per centimeter, and
 ϕ = angular displacement, in radians.

The potential energy V_{PA} stored in the acoustical capacitance of the acoustical system is

$$V_{PA} = \frac{1}{2} \frac{X^2}{C_A} \quad 3.8$$

where X = volume displacement, in cubic centimeters,
 $C_A = V/\rho c^2$ = acoustical capacitance, in (centimeters)⁵ per dyne,
 V = volume of the cavity, in cubic centimeters,
 ρ = density of air, in grams per cubic centimeter, and
 c = velocity of sound, in centimeters per second.

The energies stored in the systems is the sum of the kinetic and potential energy. The total energy stored in the four systems may be written

$$W_E = T_{KE} + V_{PE} = \frac{1}{2}Li^2 + \frac{1}{2} \frac{q^2}{C_E} \quad 3.9$$

$$W_M = T_{KM} + V_{PM} = \frac{1}{2}m\dot{x}^2 + \frac{1}{2} \frac{x}{C_M} \quad 3.10$$

$$W_R = T_{KR} + V_{PR} = \frac{1}{2}I\dot{\phi}^2 + \frac{1}{2} \frac{\phi^2}{C_R} \quad 3.11$$

$$W_A = T_{KA} + V_{PA} = \frac{1}{2}M\dot{X}^2 + \frac{1}{2} \frac{X^2}{C_A} \quad 3.12$$

where W_E , W_M , W_R , and W_A are the total energies stored in electrical, mechanical rectilinear, mechanical rotational, and acoustical systems.

The rate of change of energy with respect to time in the four systems may be written

$$\frac{dW_E}{dt} = Li \frac{di}{dt} + \frac{q\dot{q}}{C_E} = L\dot{q}\ddot{q} + \frac{q\dot{q}}{C_E} \quad 3.13$$

$$\frac{dW_M}{dt} = m\dot{x}\ddot{x} + \frac{x\dot{x}}{C_M} \quad 3.14$$

$$\frac{dW_R}{dt} = I\dot{\phi}\ddot{\phi} + \frac{\phi\dot{\phi}}{C_R} \quad 3.15$$

$$\frac{dW_A}{dt} = M\dot{X}\ddot{X} + \frac{X\dot{X}}{C_A} \quad 3.16$$

3.5. Dissipation

The rate at which electromagnetic energy D_E is converted into heat is

$$D_E = r_E i^2 \quad 3.17$$

where r_A = electrical resistance, in abohms, and

i = current, in abamperes.

Assume that the frictional force f_M upon the mass m as it slides back and forth is proportional to the velocity as follows:

$$f_M = r_M \dot{x} \quad 3.18$$

where r_M = mechanical resistance, in mechanical ohms, and
 \dot{x} = velocity, in centimeters per second.

The rate at which mechanical rectilinear energy D_M is converted into heat is

$$D_M = f_M \dot{x} = r_M \dot{x}^2 \quad 3.19$$

Assume that the frictional torque f_R upon the flywheel I as the periphery of the wheel slides against the brake is proportional to the velocity as follows:

$$f_R = r_R \dot{\phi} \quad 3.20$$

where r_R = mechanical rotational resistance, in rotational ohms, and
 $\dot{\phi}$ = angular velocity, in radians per second.

The rate at which mechanical rotational energy D_R is converted into heat is

$$D_R = f_R \dot{\phi} = r_R \dot{\phi}^2 \quad 3.21$$

The acoustical energy is converted into heat by the dissipation due to viscosity as the fluid is forced through the narrow slits. The rate at which acoustical energy D_A is converted into heat is

$$D_A = r_A \dot{X}^2 \quad 3.22$$

where r_A = acoustical resistance, in acoustical ohms, and
 \dot{X} = volume current in cubic centimeters per second.

3.6. Equations of Motion

The power delivered to a system must be equal to the rate of kinetic energy storage plus the rate of potential energy storage plus the power loss due to dissipation. The rate at which work is done or power delivered to the electrical system by the applied electromotive force is $\dot{q}E\epsilon^{j\omega t} = e\dot{q}$. The rate at which work is done or power delivered to the mechanical rectilinear system by the applied mechanical force is $\dot{x}F_M\epsilon^{j\omega t} = f_M\dot{x}$. The rate at which work is done or power delivered to the mechanical rotational system by the applied mechanical torque is $\dot{\phi}F_R\epsilon^{j\omega t} = f_R\dot{\phi}$. The rate at which work is done or power delivered to the acoustical system by the applied sound pressure is $\dot{X}P\epsilon^{j\omega t} = p\dot{X}$.

The rate of decrease of energy ($T_K + V_P$) of the system plus the rate at which work is done on the system or power delivered to the system

by the external forces must equal the rate of dissipation of energy. Writing this sentence mathematically yields the equations of motion for the four systems.

Electrical

$$L\dot{q}\ddot{q} + r_E\dot{q}^2 + \frac{q\dot{q}}{C_E} = E\epsilon^{j\omega t}\dot{q} \quad 3.23$$

$$L\ddot{q} + r_E\dot{q} + \frac{q}{C_E} = E\epsilon^{j\omega t} \quad 3.24$$

Mechanical Rectilinear

$$m\dot{x}\ddot{x} + r_M\dot{x}^2 + \frac{x\dot{x}}{C_M} = F_M\epsilon^{j\omega t}\dot{x} \quad 3.25$$

$$m\ddot{x} + r_M\dot{x} + \frac{x}{C_M} = F_M\epsilon^{j\omega t} \quad 3.26$$

Mechanical Rotational

$$I\dot{\phi}\ddot{\phi} + r_R\dot{\phi}^2 + \frac{\phi\dot{\phi}}{C_R} = F_R\epsilon^{j\omega t}\dot{\phi} \quad 3.27$$

$$I\ddot{\phi} + r_R\dot{\phi} + \frac{\phi}{C_R} = F_R\epsilon^{j\omega t} \quad 3.28$$

Acoustical

$$M\dot{X}\ddot{X} + r_A\dot{X}^2 + \frac{X\dot{X}}{C_A} = P\epsilon^{j\omega t}\dot{X} \quad 3.29$$

$$M\ddot{X} + r_A\dot{X} + \frac{X}{C_A} = P\epsilon^{j\omega t} \quad 3.30$$

The steady state solutions of the four differential equations 3.24, 3.26, 3.28 and 3.30 are

Electrical

$$\dot{q} = i = \frac{E\epsilon^{j\omega t}}{r_E + j\omega L - \frac{j\omega}{C_E}} = \frac{e}{z_E} \quad 3.31$$

Mechanical Rectilinear

$$\dot{x} = \frac{F\epsilon^{j\omega t}}{r_M + j\omega m - \frac{j\omega}{C_M}} = \frac{f_M}{z_M} \quad 3.32$$

Mechanical Rotational

$$\dot{\phi} = \frac{F \epsilon^{j\omega t}}{r_R + j\omega I - \frac{j\omega}{C_R}} = \frac{f_R}{z_R} \quad 3.33$$

Acoustical

$$\dot{X} = \frac{p \epsilon^{j\omega t}}{r_A + j\omega M - \frac{j\omega}{C_A}} = \frac{p}{z_A} \quad 3.34$$

The vector electrical impedance is

$$z_E = r_E + j\omega L - \frac{j\omega}{C_E} \quad 3.35$$

The vector mechanical rectilinear impedance is

$$z_M = r_M + j\omega m - \frac{j\omega}{C_M} \quad 3.36$$

The vector mechanical rotational impedance is

$$z_R = r_R + j\omega I - \frac{j\omega}{C_R} \quad 3.37$$

The vector acoustical impedance is

$$z_A = r_A + j\omega M - \frac{j\omega}{C_A} \quad 3.38$$

3.7. Resonant Frequency

For a certain value of L and C_E , m and C_M , I and C_R , and M and C_A there will be a certain frequency at which the imaginary component of the impedance is zero. This frequency is called the resonant frequency. At this frequency the ratio of the current to the applied voltage or the ratio of the velocity to the applied force or the ratio of the angular velocity to the applied torque or the ratio of the volume current to the applied pressure is a maximum. At the resonant frequency the current and voltage, the velocity and force, the angular velocity and torque, and the volume current and pressure are in phase.

The resonant frequency f_r in the four systems is

Electrical

$$f_r = \frac{1}{2\pi\sqrt{LC_E}} \quad 3.39$$

Mechanical Rectilinear

$$f_r = \frac{1}{2\pi\sqrt{mC_M}} \quad 3.40$$

Mechanical Rotational

$$f_r = \frac{1}{2\pi\sqrt{IC_R}} \quad 3.41$$

Acoustical

$$f_r = \frac{1}{2\pi\sqrt{MC_A}} \quad 3.42$$

3.8. Kirchhoff's Law and D'Alembert's Principle ¹

Kirchhoff's electromotive force law plays the same role in setting up the electrical equations as D'Alembert's principle does in setting up mechanical and acoustical equations. It is the purpose of this section to obtain the differential equations of electrical, mechanical rectilinear, mechanical rotational and acoustical systems employing Kirchhoff's law and D'Alembert's principle.

Kirchhoff's law is as follows: The algebraic sum of the electromotive forces around a closed circuit is zero. The differential equations for electric circuits with lumped elements may be set up employing Kirchhoff's law. The electromotive forces due to the elements in an electric circuit are

$$\text{Electromotive force of self-inductance} = -L \frac{di}{dt} = -L \frac{d^2q}{dt^2} \quad 3.43$$

$$\text{Electromotive force of electrical resistance} = -r_E i = -r_E \frac{dq}{dt} \quad 3.44$$

$$\text{Electromotive force of electrical capacitance} = -\frac{q}{C_E} \quad 3.45$$

In addition to the above electromotive forces are the electromotive forces applied externally.

¹ D'Alembert's principle as used here may be said to be a modified form of Newton's second law.

The above law may be used to derive the differential equation for the electrical circuit of Fig. 3.1. From Kirchhoff's law the algebraic sum of the electromotive forces around the circuit is zero. The equation may be written

$$L \frac{di}{dt} + r_E i + \frac{q}{C_E} = E \epsilon^{j\omega t} \quad 3.46$$

where $e = E \epsilon^{j\omega t}$ = the external applied electromotive force.

Equation 3.46 may be written

$$L \frac{d^2q}{dt^2} + r_E \frac{dq}{dt} + \frac{q}{C_E} = E \epsilon^{j\omega t} \quad 3.47$$

and is the same as equation 3.24.

The differential equations for mechanical systems may be set up employing D'Alembert's principle; namely, the algebraic sum of the forces applied to a body is zero.

The mechanical forces due to the elements in a mechanical rectilinear system are

$$\text{Mechanomotive force of mass reaction} = -m \frac{d^2x}{dt^2} \quad 3.48$$

$$\text{Mechanomotive force of mechanical rectilinear resistance} = -r_M \frac{dx}{dt} \quad 3.49$$

$$\text{Mechanomotive force of mechanical compliance} = -\frac{x}{C_M} \quad 3.50$$

In addition to the above mechanomotive forces are the mechanomotive forces applied externally.

The above principle may be used to derive the differential equation of the mechanical rectilinear system of Fig. 3.1. From D'Alembert's principle the algebraic sum of the forces applied to a body is zero. The equation may be written

$$m \frac{d^2x}{dt^2} + r_M \frac{dx}{dt} + \frac{x}{C_M} = F_M \epsilon^{j\omega t} \quad 3.51$$

where $f_M = F_M \epsilon^{j\omega t}$ = external applied mechanical force.

Equation 3.51 is the same as equation 3.26.

D'Alembert's principle may be applied to the mechanical rotational system. The rotational mechanical forces due to the elements in a mechanical rotational system are

$$\text{Rotatomotive force of moment of inertia reaction} = -I \frac{d^2\phi}{dt^2} \quad 3.52$$

$$\text{Rotatomotive force of mechanical rotational resistance} = -r_R \frac{d\phi}{dt} \quad 3.53$$

$$\text{Rotatomotive force of rotational compliance} = -\frac{\phi}{C_R} \quad 3.54$$

In addition to the above rotatomotive forces are the rotatomotive forces applied externally.

Applying D'Alembert's principle the equation for the rotational system of Fig. 3.1 may be written

$$I \frac{d^2\phi}{dt^2} + r_R \frac{d\phi}{dt} + \frac{\phi}{C_R} = F_R \epsilon^{j\omega t} \quad 3.55$$

where $f_R = F_R \epsilon^{j\omega t} =$ external applied torque.

Equation 3.55 is the same as equation 3.28.

D'Alembert's principle may be applied to the acoustical system. The acoustical pressures due to the elements in an acoustical system are

$$\text{Acoustomotive force of inertive reaction} = -M \frac{d^2X}{dt^2} \quad 3.56$$

$$\text{Acoustomotive force of acoustical resistance} = -r_A \frac{dx}{dt} \quad 3.57$$

$$\text{Acoustomotive force of acoustical capacitance} = -\frac{X}{C_A} \quad 3.58$$

In addition to the above acoustomotive forces are the acoustomotive forces applied externally.

Applying D'Alembert's principle, the equation for the acoustical system of Fig. 3.1 may be written

$$M \frac{d^2 X}{dt^2} + r_A \frac{dX}{dt} + \frac{X}{C_A} = P e^{j\omega t} \quad 3.59$$

where $p = P e^{j\omega t}$ = external applied pressure.

Equation 3.59 is the same as equation 3.30.

Equations 3.43 to 3.59, inclusively, further illustrate the analogies between electrical, mechanical rectilinear, mechanical rotational, and acoustical systems.

CHAPTER IV

ELECTRICAL, MECHANICAL RECTILINEAL, MECHANICAL ROTATIONAL AND ACOUSTICAL SYSTEMS OF TWO AND THREE DEGREES OF FREEDOM

4.1. Introduction

The analogies between the four types of vibrating systems of one degree of freedom have been considered in the preceding chapter. It is the purpose of this section to extend these analogies to systems of two and three degrees of freedom. In this chapter the differential equations for the four systems will be obtained from the expressions for the kinetic and potential energies, the dissipation and the application of Lagrange's equations.

4.2. Two Degrees of Freedom

The first consideration will be the systems shown in Fig. 4.1. In the electrical system an electromotive force acts upon an electrical capaci-

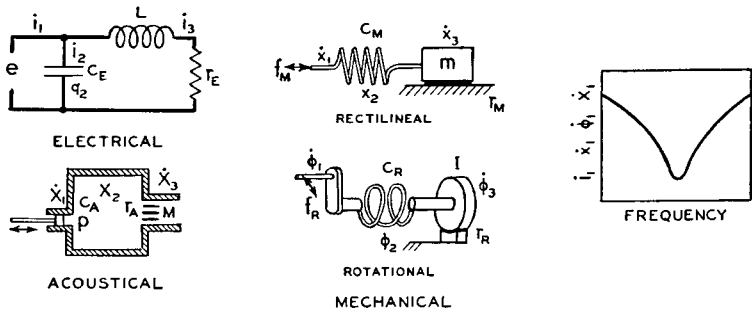

FIG. 4.1. Electrical, mechanical rectilinear, mechanical rotational and acoustical systems of two degrees of freedom and the input current, velocity, angular velocity and volume current response characteristics.

tance C_E shunted by an inductance L and an electrical resistance r_E in series. In the mechanical rectilinear system a driving force acts upon a

spring or compliance C_M connected to a mass m sliding upon a plate with a frictional force which is proportional to the velocity and designated as the mechanical rectilinear resistance r_M . In the mechanical rotational system a driving torque acts upon a spring or rotational compliance C_R connected to a flywheel of moment of inertia I and with the periphery of the wheel sliding against a brake with a frictional force which is proportional to the velocity and designated as the mechanical rotational resistance r_R . In the acoustical system a driving pressure p acts upon a volume or acoustical capacitance C_A connected to a tubular opening communicating with free space. The mass of fluid in the opening is the inertance M and the fluid resistance produced by the slits is the acoustical resistance r_A .

4.3. Kinetic Energy

The kinetic energy T_{KE} stored in the magnetic field of the electrical circuit is

$$T_{KE} = \frac{1}{2}L\dot{q}_3^2 \quad 4.1$$

where L = inductance, in abhenries, and

$\dot{q}_3 = i_3$ = current, in branch 3, in abamperes.

The kinetic energy T_{KM} stored in the mass of the mechanical rectilinear system is

$$T_{KM} = \frac{1}{2}m\dot{x}_3^2 \quad 4.2$$

where m = mass, in grams, and

\dot{x}_3 = velocity of the mass m , in centimeters per second.

The kinetic energy T_{KR} stored in the moment of inertia of the mechanical rotational system is

$$T_{KR} = \frac{1}{2}I\dot{\phi}_3^2 \quad 4.3$$

where I = moment of inertia, in gram (centimeter)² and

$\dot{\phi}_3$ = angular velocity of I , in radians per second.

The kinetic energy T_{KA} stored in the inertance of the acoustical system is

$$T_{KA} = \frac{1}{2}M\dot{X}_3^2 \quad 4.4$$

where M = inertance, in grams per (centimeter)⁴ and

\dot{X}_3 = volume current, in cubic centimeters per second.

4.4. Potential Energy

The potential energy V_{PE} stored in the electric field of the electrical circuit is

$$V_{PE} = \frac{1}{2} \frac{q_2^2}{C_E} \quad 4.5$$

where C_E = capacitance, in abfarads, and
 q_2 = charge on the electrical capacitance, in abcoulombs.

The potential energy V_{PM} stored in the compliance or spring of the mechanical rectilinear system is

$$V_{PM} = \frac{1}{2} \frac{x_2^2}{C_M} \quad 4.6$$

where C_M = compliance of the spring, in centimeters per dyne, and
 x_2 = displacement, in centimeters.

The potential energy V_{PR} stored in the rotational compliance or spring of the mechanical rotational system is

$$V_{PR} = \frac{1}{2} \frac{\phi_2^2}{C_R} \quad 4.7$$

where C_R = rotational compliance of the spring, in radians per dyne per centimeter, and
 ϕ_2 = angular displacement, in radians.

The potential energy V_{PA} stored in the acoustical capacitance of the acoustical system is

$$V_{PA} = \frac{1}{2} \frac{X_2^2}{C_A} \quad 4.8$$

where C_A = acoustical capacitance, in (centimeter)⁵ per dyne, and
 X_2 = volume displacement, in cubic centimeters.

4.5. Dissipation

The rate at which electromagnetic energy D_E is converted into heat is

$$D_E = r_E i_3^2 = r_E \dot{q}_3^2 \quad 4.9$$

where r_E = electrical resistance, in ohms, and
 $i_3 = \dot{q}_3$ = current, in abamperes.

The rate at which mechanical rectilinear energy D_M is converted into heat is

$$D_M = r_M \dot{x}_3^2 \quad 4.10$$

where r_M = mechanical rectilinear resistance, in mechanical ohms, and \dot{x}_3 = velocity, in centimeters per second.

The rate at which mechanical rotational energy D_R is converted into heat is

$$D_R = r_R \dot{\phi}_3^2 \quad 4.11$$

where r_R = mechanical rotational resistance, in rotational ohms, and $\dot{\phi}_3$ = angular velocity, in radians per second.

The rate at which acoustical energy D_A is converted into heat is

$$D_A = r_A \dot{X}_3^2 \quad 4.12$$

where r_A = acoustical resistance, in acoustical ohms, and \dot{X}_3 = volume current, in cubic centimeters per second.

4.6. Equations of Motion

Lagrange's equations for the four systems are as follows:

Electrical

$$\frac{\partial}{\partial t} \left(\frac{\partial T}{\partial \dot{q}_n} \right) - \frac{\partial(T - V)}{\partial q_n} + \frac{1}{2} \frac{\partial D}{\partial \dot{q}_n} = e_n \quad 4.13$$

where n = number independent coordinates.

Mechanical Rectilinear

$$\frac{\partial}{\partial t} \left(\frac{\partial T}{\partial \dot{x}_n} \right) - \frac{\partial(T - V)}{\partial x_n} + \frac{1}{2} \frac{\partial D}{\partial \dot{x}_n} = f_{Mn} \quad 4.14$$

Mechanical Rotational

$$\frac{\partial}{\partial t} \left(\frac{\partial T}{\partial \dot{\phi}_n} \right) - \frac{\partial(T - V)}{\partial \phi_n} + \frac{1}{2} \frac{\partial D}{\partial \dot{\phi}_n} = f_{Rn} \quad 4.15$$

Acoustical

$$\frac{\partial}{\partial t} \left(\frac{\partial T}{\partial \dot{X}_n} \right) - \frac{\partial(T - V)}{\partial X_n} + \frac{1}{2} \frac{\partial D}{\partial \dot{X}_n} = p_n \quad 4.16$$

4.7. The Electrical System

Applying Lagrange's equation 4.13,

$$e = L\ddot{q}_3 + r_E\dot{q}_3 \quad 4.17$$

$$e = \frac{q_2}{C_E} \quad 4.18$$

The electromotive force applied to the inductance and electrical resistance in series is given by equation 4.17. The electromotive force applied to the electrical capacitance in terms of the displacement is given by equation 4.18.

The relation for the currents in Fig. 4.1 is

$$i_1 = i_2 + i_3 \quad 4.19$$

Equation 4.19 may be written

$$\dot{q}_1 = \dot{q}_2 + \dot{q}_3 \quad \text{or} \quad 4.20$$

$$q_1 = q_2 + q_3 \quad 4.21$$

4.8. The Mechanical Rectilinear System

Applying Lagrange's equation 4.14,

$$f_M = m\ddot{x}_3 + r_M\dot{x}_3 \quad 4.22$$

$$f_M = \frac{x_2}{C_M} \quad 4.23$$

The force applied to the mass and mechanical rectilinear resistance is given by equation 4.22. The force applied to the spring in terms of the displacement is given by equation 4.23.

The linear displacement, at f_M , in the mechanical rectilinear system of Fig. 4.1 is the sum of the displacement of the mass m and the displacement of the compliance C_M .

$$x_1 = x_2 + x_3 \quad 4.24$$

Differentiating equation 4.24 with respect to the time the velocities are

$$\dot{x}_1 = \dot{x}_2 + \dot{x}_3 \quad 4.25$$

4.9. The Mechanical Rotational System

Applying Lagrange's equation 4.15,

$$f_R = I\ddot{\phi}_3 + r_R\dot{\phi}_3 \quad 4.26$$

$$f_R = \frac{\phi_2}{C_R} \quad 4.27$$

The torque applied to the flywheel and mechanical rotational resistance is given by equation 4.26. The torque applied to the spring is given by equation 4.27.

The angular displacement, at f_R , in the mechanical rectilinear system of Fig. 4.1 is the sum of the angular displacement of the flywheel I and the angular displacement of the rotational compliance C_R .

$$\phi_1 = \phi_2 + \phi_3 \quad 4.28$$

Differentiating equation 4.28 with respect to the time the angular velocities are

$$\dot{\phi}_1 = \dot{\phi}_2 + \dot{\phi}_3 \quad 4.29$$

4.10. The Acoustical System

Applying Lagrange's equation 4.16,

$$p = M\ddot{X}_3 + r_A\dot{X}_3 \quad 4.30$$

$$p = \frac{X_2}{C_A} \quad 4.31$$

The pressure applied to the inertance and acoustical resistance is given by equation 4.30. The pressure applied to the acoustical capacitance in terms of the volume displacement is given by equation 4.31.

The volume displacement, at p , in the acoustical system, Fig. 4.1, is the sum of the volume displacement of the inertance M and the volume displacement of the acoustic capacitance C_A .

$$X_1 = X_2 + X_3 \quad 4.32$$

The volume displacement X_1 is the volume displacement of the vibrating piston. The vibrating piston is not a part of the acoustical system. It is merely the sound pressure source which produces the sound pressure p .

Differentiating equation 4.32 with respect to the time the volume currents are

$$\dot{X}_1 = \dot{X}_2 + \dot{X}_3 \quad 4.33$$

4.11. Comparison of the Four Systems

A comparison of the coefficients of equations 4.1 to 4.33, inclusive, shows again that resistance, inductance, and capacitance are analogous to mechanical rectilinear resistance, mass, and compliance in the mechanical rectilinear system, to mechanical rotational resistance, moment of inertia and rotational compliance in the mechanical rotational system, and to acoustical resistance, inertance and acoustic capacitance in the acoustical system. A comparison of equations 4.19, 4.25, 4.29 and 4.33 shows that currents in the electrical system are analogous to velocities in the mechanical rectilinear system, to angular velocities in the mechanical rotational system, and to volume currents in the acoustical system.

The current i_3 through the inductance L and electrical resistance r_E , Fig. 4.1, is given by

$$i_3 = \frac{e}{r_E + j\omega L} \quad 4.34$$

The total current i_1 is given by

$$i_1 = \frac{e \left(r_E + j\omega L + \frac{1}{j\omega C_E} \right)}{(r_E + j\omega L) \frac{1}{j\omega C_E}} \quad 4.35$$

The current i_2 through the electrical capacitance C_E is

$$i_2 = i_1 - i_3 = ej\omega C_E \quad 4.36$$

The linear velocity \dot{x}_3 of the mass m and mechanical rectilinear resistance, r_M , Fig. 4.1, is given by

$$\dot{x}_3 = \frac{f_M}{r_M + j\omega m} \quad 4.37$$

The linear velocity \dot{x}_1 at f_M is given by

$$\dot{x}_1 = \frac{f_M \left(r_M + j\omega m + \frac{1}{j\omega C_M} \right)}{(r_M + j\omega m) \frac{1}{j\omega C_M}} \quad 4.38$$

The velocity \dot{x}_2 , the difference in linear velocity between the two ends of the spring C_M , is given by

$$\dot{x}_2 = \dot{x}_1 - \dot{x}_3 = f_M j \omega C_M \quad 4.39$$

The angular velocity $\dot{\phi}_3$ of the moment of inertia I and mechanical rotational resistance r_R , Fig. 4.1, is given by

$$\dot{\phi}_3 = \frac{f_R}{r_R + j \omega I} \quad 4.40$$

The total angular velocity $\dot{\phi}_1$ at f_R is given by

$$\dot{\phi}_1 = \frac{f_R \left(r_R + j \omega I + \frac{1}{j \omega C_R} \right)}{(r_R + j \omega I) \frac{1}{j \omega C_R}} \quad 4.41$$

The angular velocity $\dot{\phi}_2$, the difference in angular velocity between the two ends of the spring C_R , is given by

$$\dot{\phi}_2 = \dot{\phi}_1 - \dot{\phi}_3 = f_R j \omega C_R \quad 4.42$$

The volume current \dot{X}_3 through the inertance M and the acoustic resistance r_A , Fig. 4.1, is given by

$$\dot{X}_3 = \frac{p}{r_A + j \omega M} \quad 4.43$$

The total volume current \dot{X}_1 at p is given by

$$\dot{X}_1 = \frac{p \left(r_A + j \omega M + \frac{1}{j \omega C_A} \right)}{(r_A + j \omega M) \frac{1}{j \omega C_A}} \quad 4.44$$

The volume current \dot{X}_2 , the difference between the volume currents at the input and output to the acoustical capacitance, is

$$\dot{X}_2 = \dot{X}_1 - \dot{X}_3 = p j \omega C_A \quad 4.45$$

4.12. Electrical Inductive and Capacitive Coupled Systems of Two Degrees of Freedom and the Mechanical Rectilinear, Mechanical Rotational and Acoustical Analogies

It is the purpose of this section to show two additional electrical arrangements of two degrees of freedom and the mechanical rectilinear,¹ mechanical rotation and acoustical analogies.

The electrical impedances z_{E1} , z_{E2} and z_{E3} in terms of the elements of Fig. 4.2 are as follows:

$$z_{E1} = r_{E1} + j\omega L_1 + \frac{1}{j\omega C_{E1}} \quad 4.46$$

$$z_{E2} = \frac{1}{j\omega C_{E2}} \quad 4.47$$

$$z_{E3} = r_{E2} + j\omega L_2 + \frac{1}{j\omega C_{E3}} \quad 4.48$$

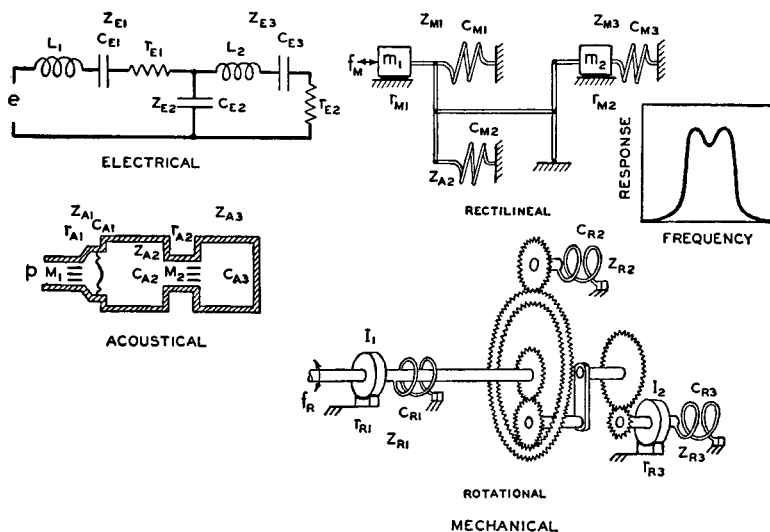

FIG. 4.2. A capacitive coupled electrical system of two degrees of freedom and the mechanical rectilinear, mechanical rotational and acoustical analogies. The graph depicts the output response frequency characteristic.

¹ For an explanation of the shunt mechanical rectilinear and mechanical rotational systems of Figs. 4.2 and 4.3, see pages 53, 54, 55 and 56 and Fig. 5.1 of Chapter V.

The mechanical rectilinear impedances z_{M1} , z_{M2} and z_{M3} in terms of the elements of Fig. 4.2 are as follows:

$$z_{M1} = r_{M1} + j\omega m_1 + \frac{1}{j\omega C_{M1}} \quad 4.49$$

$$z_{M2} = \frac{1}{j\omega C_{M2}} \quad 4.50$$

$$z_{M3} = r_{M2} + j\omega m_2 + \frac{1}{j\omega C_{M3}} \quad 4.51$$

The mechanical rotational impedances z_{R1} , z_{R2} and z_{R3} in terms of the elements of Fig. 4.2 are as follows:

$$z_{R1} = r_{M1} + j\omega I_1 + \frac{1}{j\omega C_{R1}} \quad 4.52$$

$$z_{R2} = \frac{1}{j\omega C_{R2}} \quad 4.53$$

$$z_{R3} = r_{R2} + j\omega I_2 + \frac{1}{j\omega C_{R3}} \quad 4.54$$

The acoustical impedances z_{A1} , z_{A2} , and z_{A3} in terms of the elements of Fig. 4.2 are as follows:

$$z_{A1} = r_{A1} + j\omega M_1 + \frac{1}{j\omega C_{A1}} \quad 4.55$$

$$z_{A2} = \frac{1}{j\omega C_{A2}} \quad 4.56$$

$$z_{A3} = r_{A2} + j\omega M_2 + \frac{1}{j\omega C_{A3}} \quad 4.57$$

The system in Fig. 4.3 is the same as that of Fig. 4.2 save that the shunt electrical capacitance, compliance, rotational compliance and acoustical capacitance, C_{E2} , C_{M2} , C_{R2} and C_{A2} , are replaced by the shunt inductance, mass, moment of inertia and inertance L_2 , m_2 , I_2 and M_2 .

The shunt electrical, mechanical rectilinear, mechanical rotational and acoustical shunt impedances are

$$z_{E2} = j\omega L_2 \quad 4.58$$

$$z_{M2} = j\omega m_2 \quad 4.59$$

$$z_{R2} = j\omega I_2 \quad 4.60$$

$$z_{A2} = j\omega M_2 \quad 4.61$$

The current in the branch z_{E1} is

$$i_1 = \frac{e(z_{E2} + z_{E3})}{z_{E1}z_{E2} + z_{E1}z_{E3} + z_{E2}z_{E3}} \quad 4.62$$

The velocity of the mass m_1 is

$$\dot{x}_1 = \frac{f_M(z_{M2} + z_{M3})}{z_{M1}z_{M2} + z_{M1}z_{M3} + z_{M2}z_{M3}} \quad 4.63$$

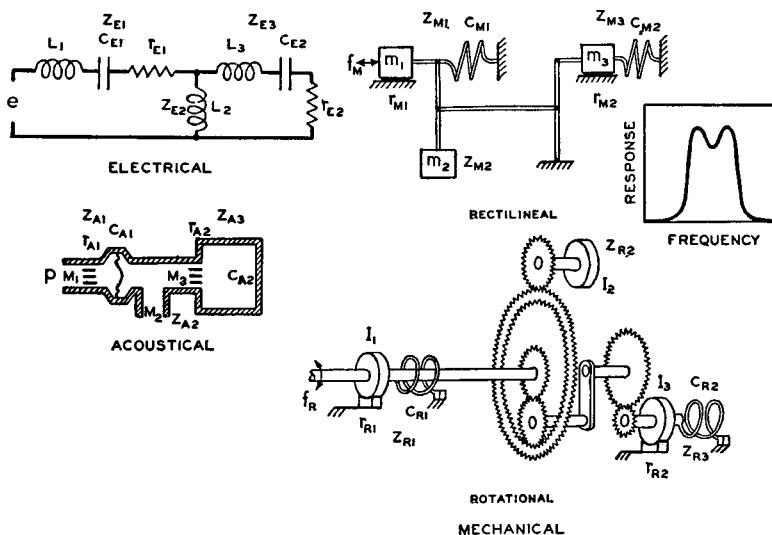

FIG. 4.3. An inductive coupled electrical system of two degrees of freedom and the mechanical rectilinear, mechanical rotational and acoustical analogies. The graph depicts the output response frequency characteristic.

The angular velocity of the moment of inertia I_1 is

$$\dot{\phi}_1 = \frac{f_R(z_{R2} + z_{R3})}{z_{R1}z_{R2} + z_{R1}z_{R3} + z_{R2}z_{R3}} \quad 4.64$$

The volume current of the inertance M_1 is

$$\dot{X}_1 = \frac{p(z_{A2} + z_{A3})}{z_{A1}z_{A2} + z_{A1}z_{A3} + z_{A2}z_{A3}} \quad 4.65$$

The current in the branch z_{E3} is

$$i_3 = \frac{e z_{E2}}{z_{E1} z_{E2} + z_{E1} z_{E3} + z_{E2} z_{E3}} \quad 4.66$$

The velocity of the mass m_3 is

$$\dot{x}_3 = \frac{f_M z_{M2}}{z_{M1} z_{M2} + z_{M1} z_{M3} + z_{M2} z_{M3}} \quad 4.67$$

The angular velocity of the moment of inertia I_3 is

$$\dot{\phi}_3 = \frac{f_R z_{R2}}{z_{R1} z_{R2} + z_{R1} z_{R3} + z_{R2} z_{R3}} \quad 4.68$$

The volume current of the inertance M_3 is

$$\dot{X}_3 = \frac{p z_{A2}}{z_{A1} z_{A2} + z_{A1} z_{A3} + z_{A2} z_{A3}} \quad 4.69$$

The response frequency characteristic of the system is shown in Figs. 4.2 and 4.3.

4.13. Electrical, Mechanical Rectilinear, Mechanical Rotational and Acoustical Systems of Three Degrees of Freedom

Systems of three degrees of freedom are shown in Fig. 4.4. Following the procedures outlined in the preceding sections it can be shown that

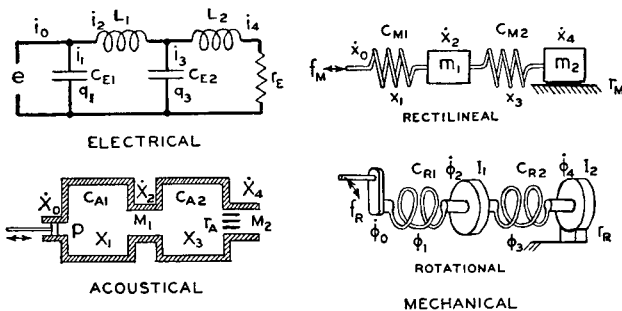

FIG. 4.4. Electrical, mechanical rectilinear, mechanical rotational and acoustical systems of three degrees of freedom.

L_1, L_2, C_{E1}, C_{E2} and r_E in the electrical system are equivalent to m_1, m_2, C_{M1}, C_{M2} and r_M in the mechanical rectilinear system, to I_1, I_2, C_{R1}, C_{R2}

and r_R in the mechanical rotational system and to M_1, M_2, C_{A1}, C_{A2} and r_A in the acoustical system. These equations also show that i_0, i_1, i_2, i_3 and i_4 in the electrical system are equivalent to $\dot{x}_0, \dot{x}_1, \dot{x}_2, \dot{x}_3$ and \dot{x}_4 in the mechanical rectilinear system, to $\dot{\phi}_0, \dot{\phi}_1, \dot{\phi}_2, \dot{\phi}_3$ and $\dot{\phi}_4$ in the mechanical rotational system and to $\dot{X}_0, \dot{X}_1, \dot{X}_2, \dot{X}_3$ and to \dot{X}_4 in the acoustical system.

The current i_0 , the linear velocity \dot{x}_0 , the angular velocity $\dot{\phi}_0$ and the volume current \dot{X}_0 are given by

$$i_0 = \frac{e[(z_{E1} + z_{E2})(z_{E3} + z_{E4}) + z_{E3}z_{E4}]}{H_E} \quad 4.70$$

$$\dot{x}_0 = \frac{f_M[(z_{M1} + z_{M2})(z_{M3} + z_{M4}) + z_{M3}z_{M4}]}{H_M} \quad 4.71$$

$$\dot{\phi}_0 = \frac{f_R[(z_{R1} + z_{R2})(z_{R3} + z_{R4}) + z_{R3}z_{R4}]}{H_R} \quad 4.72$$

$$\dot{X}_0 = \frac{p[(z_{A1} + z_{A2})(z_{A3} + z_{A4}) + z_{A3}z_{A4}]}{H_A} \quad 4.73$$

$$\text{where } z_{E1} = \frac{1}{j\omega C_{E1}} \quad z_{R1} = \frac{1}{j\omega C_{R1}} \quad 4.74 \quad 4.75$$

$$z_{E2} = j\omega L_1 \quad z_{R2} = j\omega I_1 \quad 4.76 \quad 4.77$$

$$z_{E3} = \frac{1}{j\omega C_{E2}} \quad z_{R3} = \frac{1}{j\omega C_{R2}} \quad 4.78 \quad 4.79$$

$$z_{E4} = r_E + j\omega L_2 \quad z_{R2} = r_R + j\omega I_2 \quad 4.80 \quad 4.81$$

$$z_{M1} = \frac{1}{j\omega C_{M1}} \quad z_{A1} = \frac{1}{j\omega C_{A1}} \quad 4.82 \quad 4.83$$

$$z_{M2} = j\omega m_1 \quad z_{A2} = j\omega M_1 \quad 4.84 \quad 4.85$$

$$z_{M3} = \frac{1}{j\omega C_{M2}} \quad z_{A3} = \frac{1}{j\omega C_{A2}} \quad 4.86 \quad 4.87$$

$$z_{M4} = r_M + j\omega m_2 \quad z_{A4} = r_A + j\omega M_2 \quad 4.88 \quad 4.89$$

$$H_E = z_{E1}z_{E3}z_{E4} + z_{E1}z_{E2}(z_{E3} + z_{E4}) \quad 4.90$$

$$H_M = z_{M1}z_{M3}z_{M4} + z_{M1}z_{M2}(z_{M3} + z_{M4}) \quad 4.91$$

$$H_R = z_{R1}z_{R3}z_{R4} + z_{R1}z_{R2}(z_{R3} + z_{R4}) \quad 4.92$$

$$H_A = z_{A1}z_{A3}z_{A4} + z_{A1}z_{A2}(z_{A3} + z_{A4}) \quad 4.93$$

The current i_1 , the linear velocity \dot{x}_1 , the angular $\dot{\phi}_1$ and the volume current \dot{X}_1 are given by

$$i_1 = \frac{e[z_{E2}(z_{E3} + z_{E4}) + z_{E3}z_{E4}]}{H_E} \quad 4.94$$

$$\dot{x}_1 = \frac{f_M[z_{M2}(z_{M3} + z_{M4}) + z_{M3}z_{M4}]}{H_M} \quad 4.95$$

$$\dot{\phi}_1 = \frac{f_R[z_{R2}(z_{R3} + z_{R4}) + z_{R3}z_{R4}]}{H_R} \quad 4.96$$

$$\dot{X}_1 = \frac{p[z_{A2}(z_{A3} + z_{A4}) + z_{A3}z_{A4}]}{H_A} \quad 4.97$$

The current i_2 , the linear velocity \dot{x}_2 , the angular velocity $\dot{\phi}_2$, and the volume current \dot{X}_2 are given by

$$i_2 = \frac{ez_{E1}(z_{E3} + z_{E4})}{H_E} \quad 4.98$$

$$\dot{x}_2 = \frac{f_M z_{M1}(z_{M3} + z_{M4})}{H_M} \quad 4.99$$

$$\dot{\phi}_2 = \frac{f_R z_{R1}(z_{R3} + z_{R4})}{H_R} \quad 4.100$$

$$\dot{X}_2 = \frac{p z_{A1}(z_{A3} + z_{A4})}{H_A} \quad 4.101$$

The current i_3 , the linear velocity \dot{x}_3 , the angular velocity $\dot{\phi}_3$ and the volume current \dot{X}_3 are given by

$$i_3 = \frac{e z_{E1} z_{E4}}{H_E} \quad 4.102$$

$$\dot{x}_3 = \frac{f_M z_{M1} z_{M4}}{H_M} \quad 4.103$$

$$\dot{\phi}_3 = \frac{f_R z_{R1} z_{R4}}{H_R} \quad 4.104$$

$$\dot{X}_3 = \frac{p z_{A1} z_{A4}}{H_A} \quad 4.105$$

The current i_4 , the linear velocity \dot{x}_4 , the angular velocity $\dot{\phi}_4$ and the volume current \dot{X}_4 are given by

$$i_4 = \frac{e z_{E1} z_{E3}}{H_E} \quad 4.106$$

$$\dot{x}_4 = \frac{f_M z_{M1} z_{M3}}{H_M} \quad 4.107$$

$$\dot{\phi}_4 = \frac{f_R z_{R1} z_{R3}}{H_R} \quad 4.108$$

$$\dot{X}_4 = \frac{p z_{A1} z_{A3}}{H_A} \quad 4.109$$

The equations in this section show that the equations for the electrical, mechanical rectilinear, mechanical rotational and acoustical systems are similar and analogous.

CHAPTER V

CORRECTIVE NETWORKS

5.1. Introduction

A corrective network is a structure which has a transmission characteristic that is more or less gradual in slope. Such a characteristic is obtained when an inductance, electrical capacitance or the combination of both is shunted across a line.¹ Another type of corrective network is an inductance, electrical capacitance or combination of both connected in series with a line. Resistance may be introduced as a second or third element in either shunt or series corrective networks. Various types of resistance networks may be used as attenuators or for matching dissimilar impedances. It is the purpose of this chapter to illustrate further analogies between electrical, mechanical rectilinear, mechanical rotational, and acoustical systems having similar transmission characteristics.

5.2. Two Electrical, Mechanical Rectilinear, Mechanical Rotational or Acoustical Impedances in Parallel

Two electrical impedances z_{E1} and z_{E2} are shown in parallel in Fig. 5.1. The electrical impedance z_{ET} of the two electrical impedances in parallel is given by

$$z_{ET} = \frac{z_{E1}z_{E2}}{z_{E1} + z_{E2}} \quad 5.1$$

The electromotive force e across z_{ET} is also the electromotive force across z_{E1} and z_{E2} .

The total current i_T is the vector sum of the currents i_1 and i_2 as follows:

$$i_T = i_1 + i_2 \quad 5.2$$

¹ The term "line" is used in this chapter to designate an electrical network which, prior to the introduction of the corrective network, consisted of a generator in series with two electrical impedances, termed the input and output electrical impedances.

If z_{E2} is made infinite the current i_2 in this branch is zero and the total current flows in z_{E1} , that is, $i_T = i_1$. In the same way if z_{E1} is made infinite the current i_1 in this branch is zero and the total current flows in z_{E2} , that is, $i_T = i_2$.

The mechanical rectilinear system, Fig. 5.1, consists of a system of rigid massless levers and links with frictionless bearings at the connecting

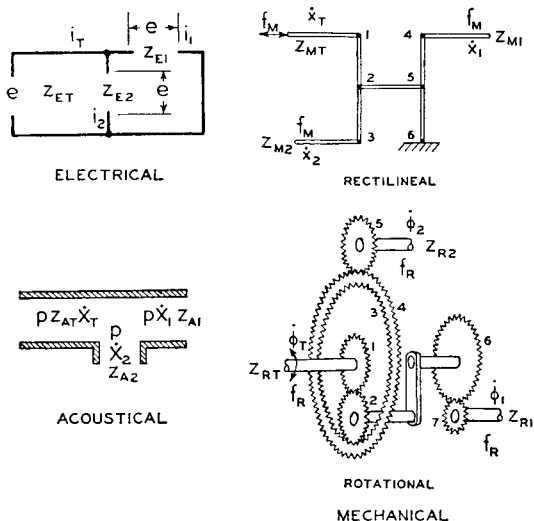

FIG. 5.1. Two electrical impedances connected in parallel and the mechanical rectilinear, mechanical rotational and acoustical analogies.

points. The member 1, 2, 3 is a lever or inflexible rod. The member 4, 5, 6 is also a lever or inflexible rod. The bearing 6 at the lower end of the lever 4, 5, 6 is connected to a rigid support. The driving force is connected by a link to point 1 on the lever 1, 2, 3. The link 2, 5 connects the mid point of the lever 1, 2, 3 with the mid point of the lever 4, 5, 6. A link connects the impedance z_{M2} to point 3 of the lever 1, 2, 3. A link connects the impedance z_{M1} to 4 of the lever 4, 5, 6.

Since the levers and links are massless and rigid the same force f_M exists at points 4 and 3 for driving the mechanical impedances z_{M1} and z_{M2} at these points. This is analogous to the same electromotive force across the impedances z_{E1} and z_{E2} in the electrical circuit.

The linear displacement x_T at I (for small amplitudes) is equal to the vector sum of the displacements x_1 and x_2 of points 3 and 4, respectively.

$$x_T = x_1 + x_2 \quad 5.3$$

Differentiating equation 5.3,

$$\dot{x}_T = \dot{x}_1 + \dot{x}_2 \quad 5.4$$

That is, the linear velocity \dot{x}_T at I is equal to the vector sum of the linear velocities \dot{x}_1 and \dot{x}_2 at points 4 and 3, respectively. Equation 5.4 is analogous to equation 5.2 for the electrical system.

Since the same force f_M exists at points 3 and 4 as the driving point and further since the velocity at I is the vector sum of the velocities at points 3 and 4, the mechanical impedances z_{M2} and z_{M1} at points 3 and 4, respectively, must be in parallel. That is, the mechanical impedance z_{MT} at point I is

$$z_{MT} = \frac{z_{M1}z_{M2}}{z_{M1} + z_{M2}} \quad 5.5$$

If z_{M2} is made infinite there can be no motion at point 3 and therefore the system behaves the same as if z_{M1} were connected to the point I . In the same way if z_{M1} is made infinite there is no motion at point 4 and the system behaves the same as if z_{M2} were connected directly to the point I .

The mechanical rotational system, Fig. 5.1, consists of a system of planetary² gears. The diameters of gears 1 and 2 are equal. The inside diameter of the large gear 3 is three times the gears 1 and 2. The outside diameter of the gear 4 is three times that of gear 5. The diameter of gear 6 is four times that of gear 7. Gear 2 is free to rotate on its shaft.

²Practically all rotational systems which connect two mechanical rotational systems in parallel are of the epicyclic train type. In this book the planetary system is used to depict and illustrate a rotational system which connects mechanical rotational impedances in parallel. There are other examples of epicyclic trains which connect mechanical rotational impedances in parallel, as for example, the differential used in automobiles and tractors, shown schematically in Fig. 5.1A. The gear 2 is keyed to the shaft I . The gear 2 drives the ring gear 3. The gears 4 and 9 rotate on bearings in the ring gear 3. The ring gear 3 rotates freely on the shaft 8. Gears 4 and 9 drive the gears 5 and 6. Gears 5 and 6 are keyed to the shafts 7 and 8, respectively. The diameter of gear 2 is one-half of the diameter of ring gear 3. With these specifications the differential of Fig. 5.1A performs the same function as the planetary system of Fig. 5.1 with the same relations existing between f_R , $\dot{\phi}_T$, $\dot{\phi}_1$, $\dot{\phi}_2$, z_{RT} , z_{R1} and z_{R2} in both illustrations.

The large gear 3-4 is free to rotate with its axis coincident with gear 1. The remainder of the gears are keyed to the respective shafts. Under these conditions if gear 7 is held stationary the angular displacement of gear 5 is the same as the driving gear 1. Or if 5 is held stationary the angular displacement of gear 7 is the same as the driving gear 1. In all the considerations which follow it is assumed that the ratios for the

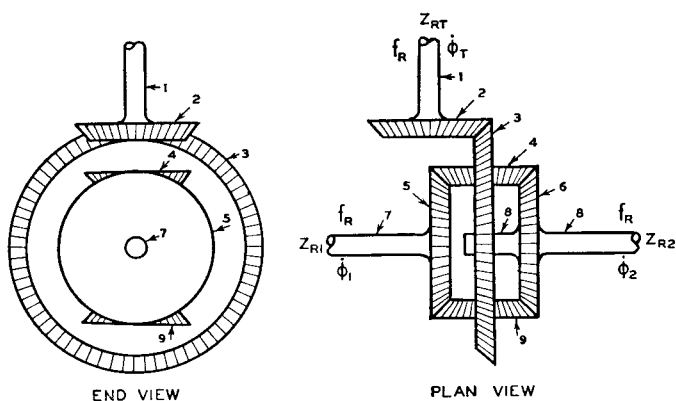

FIG. 5.1A. Differential gear train which connects two mechanical rotational impedances in parallel. This system accomplishes the same results as the planetary system of Fig. 5.1.

various gears are as outlined above. In addition it is assumed that all the gears are massless and that all the bearings are frictionless.

Since the gears are massless, the torque at gears 7 and 5 for driving the rotational impedances z_{R1} and z_{R2} is the same as the applied torque. This is analogous to the same electromotive force across the impedances z_{E1} and z_{E2} in the electrical circuit.

The angular displacement ϕ_T at gear 1 is equal to the vector sum of the angular displacement at ϕ_1 and ϕ_2 of the gears 7 and 5, respectively.

$$\phi_T = \phi_1 + \phi_2 \quad 5.6$$

Differentiating equation 5.6,

$$\dot{\phi}_T = \dot{\phi}_1 + \dot{\phi}_2 \quad 5.7$$

That is, the angular velocity $\dot{\phi}_T$ at 1 is equal to the vector sum of the angular velocities $\dot{\phi}_2$ and $\dot{\phi}_1$ at the gears 5 and 7, respectively. Equation 5.7 is analogous to equation 5.2 for the electrical system.

Since the same torque f_R exists at gears 5 and 7 as the driving point and, further, since the angular velocity at gear 1 is the vector sum of the angular velocities at gears 5 and 7, the rotational impedances z_{R2} and z_{R1} at gears 7 and 5, respectively, must be in parallel. That is, the mechanical rotational impedance z_{RT} at gear 1 is

$$z_{RT} = \frac{z_{R1}z_{R2}}{z_{R1} + z_{R2}} \quad 5.8$$

If z_{R2} is made infinite there can be no motion at gear 5 and therefore the system behaves the same as if z_{R1} were connected to the shaft of gear 1. In the same way, if z_{R1} is made infinite there is no motion at gear 7 and the system behaves the same as if z_{R2} were connected directly to the shaft of gear 1.

The acoustical system of Fig. 5.1 consists of a three way connector. The dimensions are assumed to be small compared to the wavelength. Therefore, the pressure which actuates the two acoustical impedances is the same as the driving pressure. The total volume current \dot{X}_T is the vector sum of the volume current \dot{X}_1 and \dot{X}_2 , that is

$$\dot{X}_T = \dot{X}_1 + \dot{X}_2 \quad 5.9$$

Equation 5.9 is analogous to equation 5.2 for the electrical system. The input acoustical impedance is

$$z_{AT} = \frac{z_{A1}z_{A2}}{z_{A1} + z_{A2}} \quad 5.10$$

If z_{A2} is made infinite, there is no volume current in this branch and of course z_{AT} becomes z_{A1} . In the same way if z_{A1} is made infinite z_{AT} becomes z_{A2} . Thus it will be seen that the acoustical system of Fig. 5.1 is analogous to the electrical system of Fig. 5.1.

5.3. Shunt Corrective Networks

In a shunt corrective electrical network an electrical resistance, inductance, electrical capacitance or a combination of these elements is shunted across a line.³

³ The term "line" is used to designate an electrical network which prior to the introduction of the corrective electrical network consisted of a generator in series with two electrical impedances z_{E1} and z_{E3} , termed the input and output electrical impedances. The shunt corrective electrical network z_{E2} is connected in parallel with the output electrical impedance z_{E3} .

The output current i_3 of a line shunted by an electrical network is given by

$$i_3 = \frac{e z_{E2}}{z_{E1} z_{E2} + z_{E1} z_{E3} + z_{E2} z_{E3}} \quad 5.11$$

where z_{E1} = input electrical impedance,
 z_{E2} = electrical impedance of the corrective electrical network,
 z_{E3} = output electrical impedance, or the electrical impedance connected in shunt with the network, and
 e = electromotive force in series with the input electrical impedance.

The output velocity \dot{x}_3 of a mechanical rectilinear network which is analogous to the shunt electrical network is given by

$$\dot{x}_3 = \frac{f_M z_{M2}}{z_{M1} z_{M2} + z_{M1} z_{M3} + z_{M2} z_{M3}} \quad 5.12$$

where z_{M1} = input mechanical rectilinear impedance,
 z_{M2} = mechanical rectilinear impedance of the corrective mechanical rectilinear network,
 z_{M3} = output mechanical rectilinear impedance, and
 f_M = mechanical driving force in series with the input mechanical rectilinear impedance.

The output angular velocity $\dot{\phi}_3$ of a mechanical rotational network which is analogous to the shunt electrical network is given by

$$\dot{\phi}_3 = \frac{f_R z_{R2}}{z_{R1} z_{R2} + z_{R1} z_{R3} + z_{R2} z_{R3}} \quad 5.13$$

where z_{R1} = input mechanical rotational impedance,
 z_{R2} = mechanical rotational impedance of the corrective mechanical rotational network,
 z_{R3} = output mechanical rotational impedance, and
 f_R = driving torque in series with the input rotational impedance.

The output volume current \dot{X}_3 of an acoustical network which is analogous to the shunt electrical network is given by

$$\dot{X}_3 = \frac{p z_{A2}}{z_{A1} z_{A2} + z_{A1} z_{A3} + z_{A2} z_{A3}} \quad 5.14$$

where z_{A1} = input acoustical impedance,

z_{A2} = acoustical impedance of the corrective network,

z_{A3} = output acoustical impedance, and

p = driving pressure in series with the input acoustical impedance.

5.4. Inductance in Shunt with a Line and the Mechanical Rectilinear, Mechanical Rotational and Acoustical Analogies

In Fig. 5.2 an inductance is shunted across a line. The electrical impedance of an inductance is

$$z_{E2} = j\omega L \quad 5.15$$

where $\omega = 2\pi f$,

f = frequency, in cycles per second, and

L = inductance, in abhenries.

Equations 5.11 and 5.15 show that if the electrical impedance of the inductance is small compared to the input and output electrical impedances, the transmission will be small. If the electrical impedance of the inductance is large compared to the input and output electrical impedances, the attenuation introduced by the inductance will be negligible. Since the electrical impedance of an inductance is proportional to the frequency, the transmission will increase with frequency as shown by the characteristic ⁴ of Fig. 5.2.

The mechanical rectilinear impedance of the mass in Fig. 5.2 is

$$z_{M2} = j\omega m \quad 5.16$$

where m = mass, in grams.

When the mass reactance in the mechanical rectilinear system of Fig. 5.2 is small compared to the load or driving mechanical rectilinear imped-

⁴ The verbal description and the depicted transmission frequency characteristics in this chapter tacitly assume preponderately resistive input and output impedances. Of course the equations are valid for any kind of input and output impedances.

ance, equations 5.12 and 5.16 show that the velocity of the mass will be relatively large and there will be very little velocity transmitted to the load. If the mass reactance is comparatively large the mass will remain practically stationary and the behavior will be the same as a directly coupled system. Since the mechanical rectilinear impedance of a mass is proportional to the frequency, the transmission will increase with frequency as shown by the characteristic of Fig. 5.2.

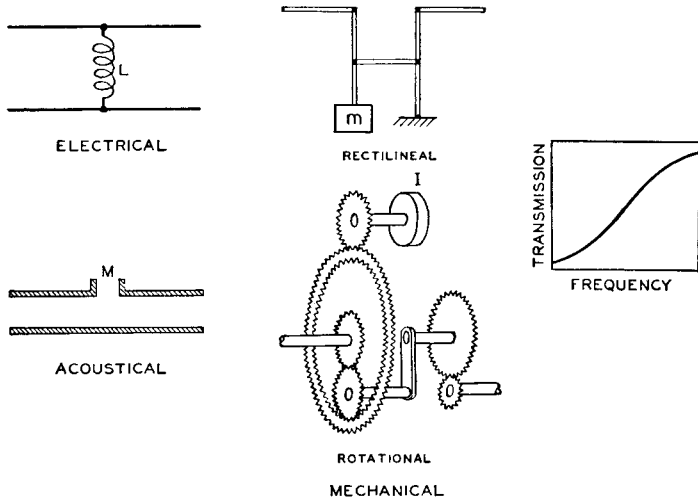

FIG. 5.2. Inductance in shunt with a line and the mechanical rectilinear, mechanical rotational and acoustical analogies. The graph depicts the transmission frequency characteristic.

The mechanical rotational impedance of the flywheel in Fig. 5.2 is

$$z_{R2} = j\omega I \tag{5.17}$$

where I = moment of inertia, in gram (centimeter)².

When the moment of inertia reactance in the mechanical rotational system of Fig. 5.2 is small compared to the load or driving mechanical rotational impedance, equations 5.13 and 5.17 show that the angular velocity of the flywheel will be relatively large and there will be very little angular velocity transmitted to the load. If the moment of inertia reactance is comparatively large the flywheel will remain practically stationary and the behavior will be the same as a directly coupled system.

Since the mechanical rotational impedance of a moment of inertia is proportional to the frequency, the transmission will increase with frequency as shown by the characteristic of Fig. 5.2.

The acoustical system of Fig. 5.2 consists of a pipe with a side branch forming an inertance. The acoustical impedance of the inertance in Fig. 5.2 is

$$z_{A2} = j\omega M \quad 5.18$$

where $M =$ inertance, in grams per (centimeter)⁴.

Equations 5.14 and 5.18 show that at low frequencies the acoustical reactance of the inertance is small compared to the acoustical impedance of the pipe and the sound is shunted out through the hole. At high frequencies the acoustical reactance of the inertance is large compared to the acoustical impedance of the pipe and the sound wave flows down the pipe the same as it would in the absence of a branch. Since the acoustical impedance of an inertance is proportional to the frequency, the transmission will increase with frequency as shown by the characteristic of Fig. 5.2.

5.5. Electrical Capacitance in Shunt with a Line and the Mechanical Rectilinear, Mechanical Rotational and Acoustical Analogies

In Fig. 5.3 an electrical capacitance is shunted across a line. The electrical impedance of an electrical capacitance is

$$z_{E2} = \frac{1}{j\omega C_E} \quad 5.19$$

where $C_E =$ electrical capacitance, in abfarads.

The electrical reactance of an electrical capacitance is inversely proportional to the frequency. Therefore, from equations 5.11 and 5.19 the transmission will decrease with increase in frequency as shown by the characteristic of Fig. 5.3.

The mechanical rectilinear impedance of the compliance in Fig. 5.3 is

$$z_{M2} = \frac{1}{j\omega C_M} \quad 5.20$$

where $C_M =$ compliance, in centimeters per dyne.

The mechanical rectilinear reactance of the compliance of the rectilinear system, Fig. 5.3, is inversely proportional to the frequency. Equations 5.12 and 5.20 show that at low frequencies the velocity at the input to the compliance will be small and the behavior will be practically the same as that of a directly coupled system. At high frequencies the velocity of the compliance will be practically the same as the input

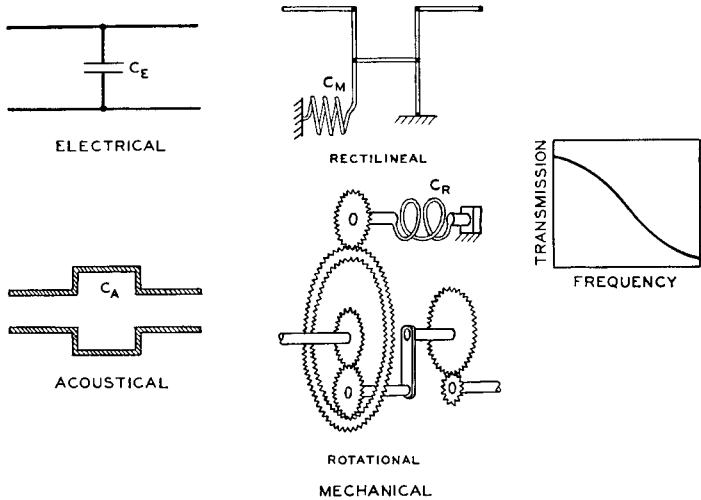

FIG. 5.3. Electrical capacitance in shunt with a line and the mechanical rectilinear, mechanical rotational and acoustical analogies. The graph depicts the transmission frequency characteristic.

velocity and there will be very little velocity transmitted to the load. The transmission characteristic of this system obtained from equations 5.12 and 5.20 is shown in Fig. 5.3.

The mechanical rotational impedance of the rotational compliance of Fig. 5.3 is

$$z_{R2} = \frac{1}{j\omega C_R} \tag{5.21}$$

where C_R = rotational compliance, in radians per dyne per centimeter.

The mechanical rotational impedance of the rotational compliance of the mechanical rotational system of Fig. 5.3 is inversely proportional to the frequency. Equations 5.13 and 5.21 show that at low frequencies

the angular velocity at the input to the rotational compliance will be small and the behavior will be practically the same as that of a directly coupled system. At high frequencies the angular velocity of the rotational compliance will be the same as the input angular velocity and there will be very little angular velocity transmitted to the load. The transmission characteristic of this system obtained from equations 5.13 and 5.21 is shown in Fig. 5.3.

The acoustical system of Fig. 5.3 consists of a pipe with an enlarged portion forming an acoustical capacitance. The acoustical impedance of an acoustical capacitance is

$$z_{A2} = \frac{1}{j\omega C_A} \quad 5.22$$

where C_A = acoustical capacitance, in (centimeter)⁵ per dyne.

At low frequencies the acoustical reactance of the acoustical capacitance is large compared to the impedance of the pipe and the sound flows down the pipe the same as it would in the absence of the enlargement. At high frequencies the acoustical reactance of the acoustical capacitance is small compared to the acoustical impedance of the pipe and the sound is shunted out by the enlargement. Since the acoustical reactance is inversely proportional to the frequency, equations 5.14 and 5.22 show that the transmission will decrease with frequency as shown by the characteristic of Fig. 5.3.

5.6. Inductance and Electrical Capacitance in Series, in Shunt with a Line and the Mechanical Rectilinear, Mechanical Rotational and Acoustical Analogies

Fig. 5.4 shows an inductance and electrical capacitance connected in series across a line. The mechanical rectilinear, mechanical rotational, and acoustical analogies are also shown in Fig. 5.4.

The electrical impedance of the electrical network is

$$z_{E2} = j\omega L + \frac{1}{j\omega C_E} \quad 5.23$$

where L = inductance, in abhenries, and
 C_E = electrical capacitance, in abfarads.

The output current can be obtained from equations 5.11 and 5.23.

The mechanical rectilinear impedance of the mechanical rectilinear system is

$$z_{M2} = j\omega m + \frac{1}{j\omega C_M} \tag{5.24}$$

where m = mass, in grams, and

C_M = compliance, in centimeters per dyne.

The output velocity can be obtained from equations 5.12 and 5.24.

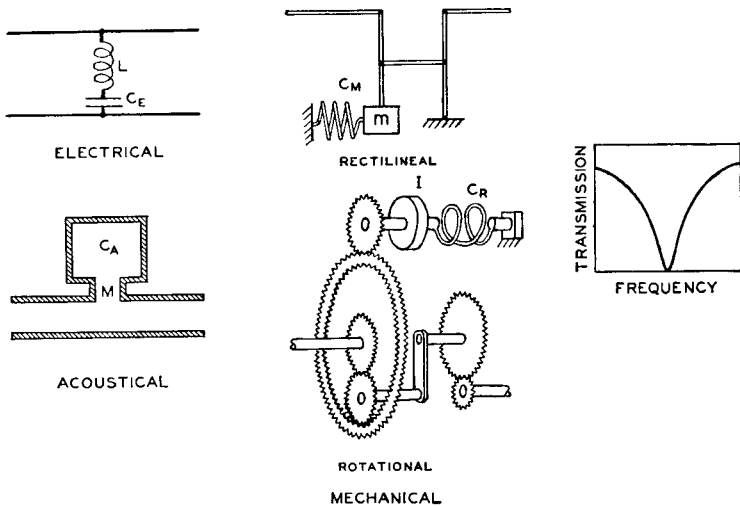

FIG. 5.4. Inductance and electrical capacitance in series, in shunt with a line and the mechanical rectilinear, mechanical rotational and acoustical analogies. The graph depicts the transmission frequency characteristic.

The mechanical rotational impedance of the mechanical rotational system is

$$z_{R2} = j\omega I + \frac{1}{j\omega C_R} \tag{5.25}$$

where I = moment of inertia, in gram (centimeter)², and

C_R = rotational compliance, in radians per dyne per centimeter.

The output angular velocity can be obtained from equations 5.13 and 5.25.

The acoustical impedance of the acoustical system is

$$z_{A2} = j\omega M + \frac{1}{j\omega C_A} \quad 5.26$$

where M = inertance, in grams per (centimeter)⁴, and
 C_A = acoustical capacitance, in (centimeter)⁵ per dyne.

The output volume current can be obtained from equations 5.14 and 5.26.

At low frequencies the four systems behave the same as those of Fig. 5.3 and there is very little attenuation. At high frequencies the systems behave the same as those of Fig. 5.2 and there is very little attenuation. At the resonant frequency of the inductance and the electrical capacitance the electrical impedance is zero and equations 5.11 and 5.23 show that there is no transmission at this frequency. At the resonant frequency of the mass and compliance no motion is transmitted because the force required to drive the resonant system is zero. Equations 5.12 and 5.24 also show that there is no transmission at the resonant frequency of the mass and compliance. At the resonant frequency of the moment of inertia and rotational compliance no angular motion is transmitted because the torque required to actuate the resonant system is zero. Equations 5.13 and 5.25 also show that there is no transmission at the resonant frequency of the moment of inertia and rotational compliance. At the resonant frequency of the inertance and acoustical capacitance there will be no transmission because the pressure at the input to the resonator is zero. Equations 5.14 and 5.26 also show that there is no transmission at the resonant frequency of the inertance and acoustical capacitance. The transmission characteristics of the four systems are shown in Fig. 5.4.

5.7. Inductance and Electrical Capacitance in Parallel, in Shunt with a Line and the Mechanical Rectilinear, Mechanical Rotational and Acoustical Analogies

Fig. 5.5 shows an inductance and electrical capacitance connected in parallel across a line. The mechanical rectilinear, mechanical rotational and acoustical equivalents are also shown in Fig. 5.5.

The electrical impedance of the electrical network of Fig. 5.5 is

$$z_{E2} = \frac{j\omega L}{1 - \omega^2 LC_E} \tag{5.27}$$

where L = inductance, in abhenries, and
 C_E = electrical capacitance, in abfarads.

The output current can be obtained from equations 5.11 and 5.27.

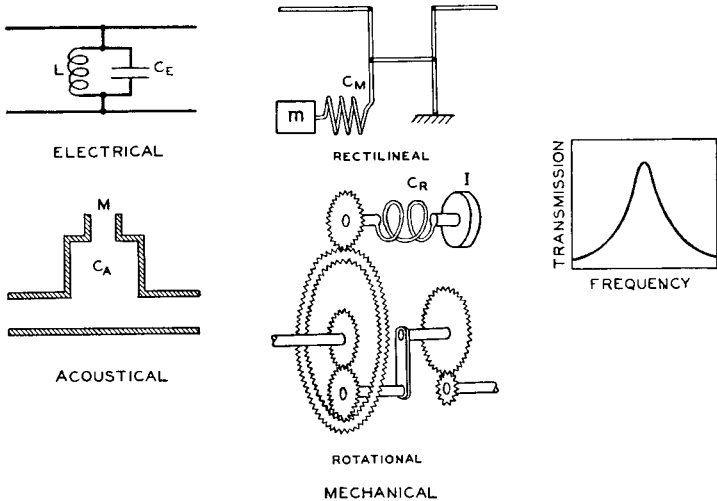

FIG. 5.5. Inductance and electrical capacitance in parallel, in shunt with a line and the mechanical rectilinear, mechanical rotational and acoustical analogies. The graph depicts the transmission frequency characteristic.

The mechanical rectilinear impedance of the mechanical rectilinear system of Fig. 5.5 is

$$z_{M2} = \frac{j\omega m}{1 - \omega^2 m C_M} \tag{5.28}$$

where m = mass, in grams, and
 C_M = compliance, in centimeters per dyne.

The output velocity can be obtained from equations 5.12 and 5.28.

The mechanical rotational impedance of the mechanical rotational system of Fig. 5.5 is

$$z_{R2} = \frac{j\omega I}{1 - \omega^2 I C_R} \quad 5.29$$

where I = moment of inertia, in gram (centimeter)², and

C_R = rotational compliance, in radians per dyne per centimeter.

The output angular velocity can be obtained from equations 5.13 and 5.29.

The acoustical impedance of the acoustical system of Fig. 5.5 is

$$z_{A2} = \frac{j\omega M}{1 - \omega^2 M C_A} \quad 5.30$$

where M = inertance, in grams per (centimeter)⁴, and

C_A = acoustical capacitance, in (centimeter)⁵ per dyne.

The output volume current can be obtained from equations 5.14 and 5.30.

At low frequencies the systems behave the same as those of Fig. 5.2 and the transmission is small. At high frequencies the systems behave the same as those of Fig. 5.3 and the transmission is again small. At the resonant frequency of the inductance and electrical capacitance the electrical impedance is infinite and equations 5.11 and 5.27 show that the shunt circuit introduces no attenuation at the resonant frequency. At the resonant frequency of the mass and compliance the input to the spring does not move because the mechanical rectilinear impedance is infinite and the behavior is the same as a directly coupled system. Equations 5.12 and 5.28 also show that there is no attenuation due to the shunt system at the resonant frequency of the mass and compliance. At the resonant frequency of the moment of inertia with the rotational compliance the input to the spring will not turn because the mechanical rotational impedance is infinite and the behavior is the same as a directly coupled system. Equations 5.13 and 5.29 also show that there is no attenuation due to the shunt system at the resonant frequency. At the resonant frequency of the inertance and acoustical capacitance the input volume current is zero because the acoustical impedance is infinite and the behavior is the same as a plain pipe. Equations 5.14 and 5.30 also show that there is no attenuation due to the shunt system at the reso-

nant frequency. The transmission characteristics of the four systems are shown in Fig. 5.5.

5.8. Electrical Resistance, Inductance and Electrical Capacitance in Series, in Shunt with a Line and the Mechanical Rectilinear, Mechanical Rotational and Acoustical Analogies

Fig. 5.6 shows an electrical resistance, inductance and electrical capacitance in series, in shunt with a line. The mechanical rectilinear, mechan-

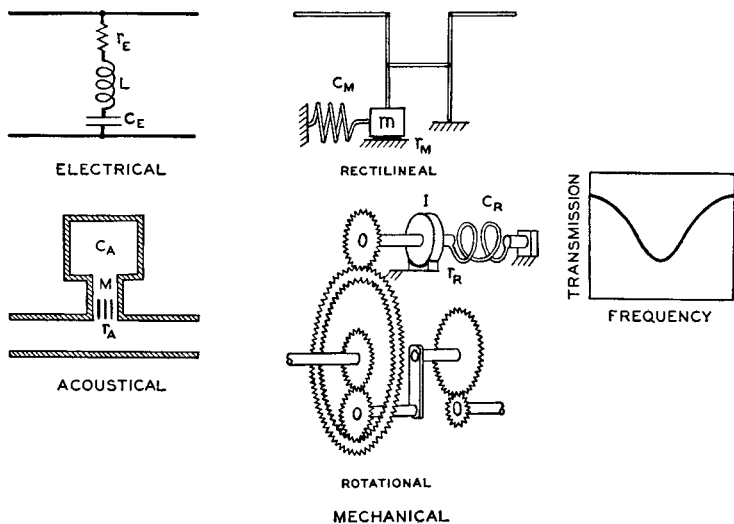

FIG. 5.6. Electrical resistance, inductance and electrical capacitance in series, in shunt with a line and the mechanical rectilinear, mechanical rotational and acoustical analogies. The graph depicts the transmission frequency characteristic.

ical rotational and acoustical analogies are also shown in Fig. 5.6. The electrical impedance of the electrical network is

$$z_{E2} = r_E + j\omega L + \frac{1}{j\omega C_E} \tag{5.31}$$

where r_E = electrical resistance, in abohms,
 L = inductance, in abhenries, and
 C_E = electrical capacitance, in abfarads.

The output current can be obtained from equations 5.11 and 5.31.

The mechanical rectilinear impedance of the mechanical rectilinear system is

$$z_{M2} = r_M + j\omega m + \frac{1}{j\omega C_M} \quad 5.32$$

where r_M = mechanical rectilinear resistance, in mechanical ohms,
 m = mass, in grams,
 C_M = compliance, in centimeters per dyne.

The output velocity can be obtained from equations 5.12 and 5.32.

The mechanical rotational impedance of the mechanical rotational system is

$$z_{R2} = r_R + j\omega I + \frac{1}{j\omega C_R} \quad 5.33$$

where r_R = mechanical rotational resistance, in rotational ohms,
 I = moment of inertia, in gram (centimeter)², and
 C_R = rotational compliance, in radians per dyne per centimeter.

The output rotational velocity can be obtained from equations 5.13 and 5.33.

The acoustical impedance of the acoustical system is

$$z_{A2} = r_A + j\omega M + \frac{1}{j\omega C_A} \quad 5.34$$

where r_A = acoustical resistance, in acoustical ohms,
 M = inertance, in grams per (centimeter)⁴, and
 C_A = acoustical capacitance, in (centimeter)⁵ per dyne.

The output volume current can be obtained from equations 5.14 and 5.34.

At low frequencies the systems behave the same as those of Fig. 5.3 and there is very little attenuation. At high frequencies the systems behave the same as those of Fig. 5.2 and there is very little attenuation. At the resonant frequency of the inductance and electrical capacitance the electrical reactance is zero. Therefore, from equations 5.11 and 5.31 the transmission as influenced by the network is governed by the electrical resistance. At the resonant frequency of the mass and compliance the mechanical rectilinear reactance is zero. Therefore, from equations 5.12 and 5.32 the transmission as influenced by the mechanical rectilinear

system is governed by the mechanical rectilinear resistance. At the resonant frequency of the moment of inertia and rotational compliance the mechanical rotational reactance is zero. Therefore, from equations 5.13 and 5.33 the transmission as influenced by the mechanical rotational system is governed by the mechanical rotational resistance. At the resonant frequency of the inertance and acoustical capacitance the acoustical reactance is zero. Therefore, from equations 5.14 and 5.34 the transmission as influenced by the acoustical system is governed by the acoustical resistance. The transmission characteristic of these systems is shown in Fig. 5.6. This characteristic at the high and low frequencies is the same as that of Fig. 5.4. However, in the region of resonance the resistance in each of the four systems decreases the attenuation as depicted by the transmission characteristic of Fig. 5.6.

5.9. Electrical Resistance, Inductance and Electrical Capacitance in Parallel, in Shunt with a Line and the Mechanical Rectilinear, Mechanical Rotational and Acoustical Analogies

Fig. 5.7 shows an electrical resistance, inductance and electrical capacitance connected in parallel across a line. The mechanical rectilinear, mechanical rotational and acoustical analogies are also shown in Fig. 5.7. The electrical impedance of the electrical network is

$$z_{E2} = \frac{j\omega r_E L}{r_E - \omega^2 r_E L C_E + j\omega L} \quad 5.35$$

where r_E = electrical resistance, in abohms,
 L = inductance, in abhenries, and
 C_E = electrical capacitance, in abfarads.

The output current can be obtained from equations 5.11 and 5.35. The mechanical rectilinear impedance of the mechanical system is

$$z_{M2} = \frac{j\omega r_M m}{r_M - \omega^2 r_M m C_M + j\omega m} \quad 5.36$$

where r_M = mechanical rectilinear resistance, in mechanical ohms,
 m = mass, in grams, and
 C_M = compliance, in centimeters per dyne.

The output velocity can be obtained from equations 5.12 and 5.36.

The mechanical rotational impedance of the rotational system is

$$z_{R2} = \frac{j\omega r_R I}{r_R - \omega^2 r_R I C_R + j\omega I} \quad 5.37$$

where r_R = mechanical rotational resistance, in rotational ohms,

I = moment of inertia, in gram (centimeter)², and

C_R = rotational compliance, in radians per dyne per centimeter.

The output rotational velocity can be obtained from equations 5.13 and 5.37.

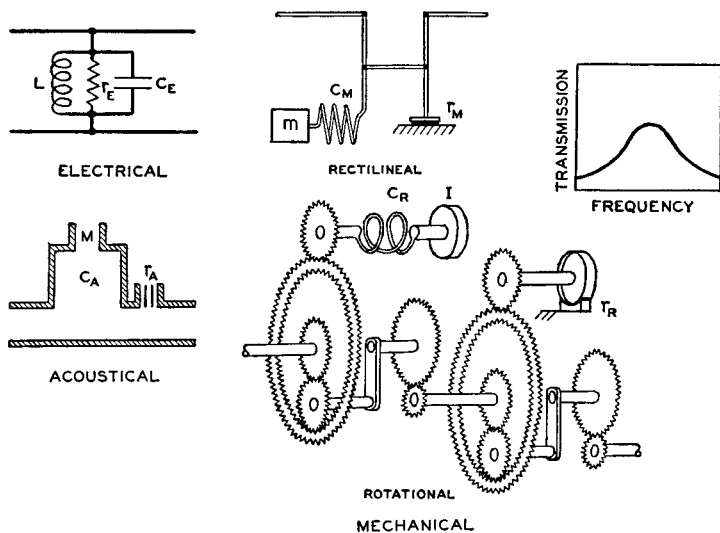

FIG. 5.7. Electrical resistance, inductance and electrical capacitance in parallel, in shunt with a line and the mechanical rectilinear, mechanical rotational and acoustical analogies. The graph depicts the transmission frequency characteristic.

The acoustical impedance of the acoustical system is

$$z_{A2} = \frac{j\omega r_A M}{r_A - \omega^2 r_A M C_A + j\omega M} \quad 5.38$$

where r_A = acoustical resistance, in acoustical ohms,

M = inertance, in grams per (centimeter)⁴, and

C_A = acoustical capacitance, in (centimeter)⁵ per dyne.

The output volume current can be obtained from equations 5.14 and 5.38.

At low frequencies the systems behave the same as those of Fig. 5.2 and the transmission is small. At high frequencies the systems behave the same as those of Fig. 5.3 and the transmission is again small. At the resonant frequency the electrical reactance is infinite and therefore from equations 5.11 and 5.35 the attenuation is due to the electrical resistance. At the resonant frequency of the mass and compliance, Fig. 5.7, the mechanical rectilinear reactance is infinite and therefore from equations 5.12 and 5.36 the attenuation is due to the mechanical rectilinear resistance. At the resonant frequency of the moment of inertia and rotational compliance, Fig. 5.7, the mechanical rotational reactance is infinite and from equations 5.13 and 5.37 the attenuation is due to the mechanical rotational resistance. At the resonant frequency of the inertance and acoustical capacitance, Fig. 5.7, the acoustical reactance is infinite and from equations 5.14 and 5.38 the attenuation is due to the acoustical resistance. The transmission characteristic of these systems is shown in Fig. 5.7. This characteristic at the low and high frequencies is the same as that of Fig. 5.5. However, in the region of resonance the resistance in each of the four systems introduces attenuation as depicted by the transmission characteristic of Fig. 5.7.

5.10. Series Corrective Networks

In a series electrical network an electrical resistance, inductance, electrical capacitance or a combination of these elements is connected in series with a line.⁵

The output current i_3 of a line containing a series electrical network is given by

$$i_3 = \frac{e}{z_{E1} + z_{E2} + z_{E3}} \quad 5.39$$

where z_{E1} = input electrical impedance,

z_{E2} = electrical impedance of the corrective electrical network,

z_{E3} = output electrical impedance, and

e = electromotive force in series with the three electrical impedances.

⁵ The term "line" is used to designate an electrical network which prior to the introduction of the corrective electrical network consisted of a generator in series with two electrical impedances z_{E1} and z_{E3} , termed the input and output electrical impedances. The series corrective electrical network z_{E2} is connected in series with the input and output electrical impedances z_{E1} and z_{E3} .

The output velocity \dot{x}_3 of a mechanical rectilinear network which is analogous to the series electrical network is given by

$$\dot{x}_3 = \frac{f_M}{z_{M1} + z_{M2} + z_{M3}} \quad 5.40$$

where z_{M1} = input mechanical rectilinear impedance,

z_{M2} = mechanical rectilinear impedance of the corrective mechanical rectilinear network,

z_{M3} = output mechanical rectilinear impedance, and

f_M = mechanical driving force in series with mechanical impedances.

The output angular velocity $\dot{\phi}_3$ of a mechanical rotational network which is analogous to the series electrical network is given by

$$\dot{\phi}_3 = \frac{f_R}{z_{R1} + z_{R2} + z_{R3}} \quad 5.41$$

where z_{R1} = input mechanical rotational impedance,

z_{R2} = mechanical rotational impedance of the corrective mechanical rotational network,

z_{R3} = output mechanical rotational impedance, and

f_R = rotational driving torque in series with the mechanical impedances.

The output volume current \dot{X}_3 of an acoustical network which is analogous to the series electrical network is given by

$$\dot{X}_3 = \frac{p}{z_{A1} + z_{A2} + z_{A3}} \quad 5.42$$

where z_{A1} = input acoustical impedance,

z_{A2} = acoustical impedance of the corrective acoustical network,

z_{A3} = output acoustical impedance, and

p = driving pressure in series with the acoustical impedances.

5.11. Inductance in Series with a Line and the Mechanical Rectilinear, Mechanical Rotational and Acoustical Analogies

In Fig. 5.8 an inductance is connected in series with a line. The electrical impedance of the inductance is

$$z_{E2} = j\omega L \quad 5.43$$

where L = inductance, in abhenries.

Equations 5.39 and 5.43 show that if the electrical impedance of the inductance is small compared to the input and output electrical impedances the attenuation introduced by the inductance will be small. If the electrical impedance of the inductance is large compared to the input and output electrical impedances the current transmission will be small. Since the electrical impedance of an inductance is proportional to the frequency, the transmission will decrease with frequency as shown in Fig. 5.8.

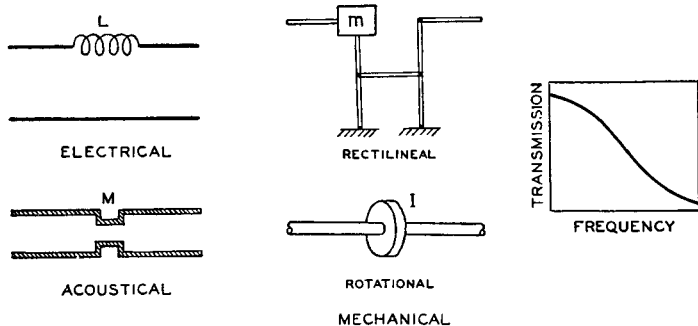

FIG. 5.8. Inductance in series with a line and the mechanical rectilinear, mechanical rotational and acoustical analogies. The graph depicts the transmission frequency characteristic.

The mechanical rectilinear impedance of the mass in Fig. 5.8 is

$$z_{M2} = j\omega m \quad 5.44$$

where m = mass, in grams.

In the mechanical rectilinear system of Fig. 5.8 equations 5.40 and 5.44 show that if the mass reactance is small compared to the load or driving mechanical rectilinear impedance the addition of the mass will cause very little reduction in the velocity transmitted to the load. If the mass reactance is comparatively large the mass will remain practically stationary and the velocity transmitted to the load will be small. Since the mechanical rectilinear impedance of a mass is proportional to the frequency, the transmission will decrease with frequency as shown by the characteristic of Fig. 5.8.

The mechanical rotational impedance of the flywheel in Fig. 5.8 is

$$z_{R2} = j\omega I \quad 5.45$$

where I = moment of inertia, in gram (centimeters)².

In the mechanical rotational system of Fig. 5.8 equations 5.41 and 5.45 show that if the moment of inertia reactance is small compared to the load or driving mechanical rectilinear impedance the addition of the moment of inertia will cause very little reduction in the angular velocity transmitted to the load. If the moment of inertia reactance is comparatively large the flywheel will remain practically stationary and the velocity transmitted to the load will be small. Since the mechanical rotational impedance of a moment of inertia is proportional to the frequency, the transmission will decrease with frequency as shown by the characteristic of Fig. 5.48.

The acoustical system of Fig. 5.8 consists of a pipe with a constriction which forms an inertance. The acoustical impedance of the inertance in Fig. 5.8 is

$$z_{A2} = j\omega M \quad 5.46$$

where M = inertance, in grams per (centimeter)⁴.

Equations 5.42 and 5.46 show that at the low frequencies where the acoustical impedance of an inertance is small compared to input and output acoustical impedances the attenuation introduced by the inertance is small. At the high frequencies the acoustical impedance of the inertance is large and the transmission is small. Since the acoustical impedance of an inertance is proportional to the frequency the transmission will decrease with frequency as shown by the characteristic of Fig. 5.8.

5.12. Electrical Capacitance in Series with a Line and the Mechanical Rectilinear, Mechanical Rotational and Acoustical Analogies

In Fig. 5.9 an electrical capacitance is connected in series with a line. The electrical impedance of the electrical capacitance of Fig. 5.9 is

$$z_{E2} = \frac{1}{j\omega C_E} \quad 5.47$$

where C_E = electrical capacitance, in abfarads.

Equation 5.39 shows that if the electrical impedance of the electrical capacitance is large compared to the input or output electrical impedances, the attenuation introduced by the electrical capacitance will be large. If the electrical impedance of the electrical capacitance is small compared to the input and output electrical impedances the attenuation

will be small. Since the electrical impedance of an electrical capacitance is inversely proportional to the frequency, as shown by equation 5.47, the transmission will increase with frequency as shown in Fig. 5.9.

The mechanical rectilinear impedance of Fig. 5.9 is

$$z_{M2} = \frac{1}{j\omega C_M} \quad 5.48$$

where C_M = compliance, in centimeters per dyne.

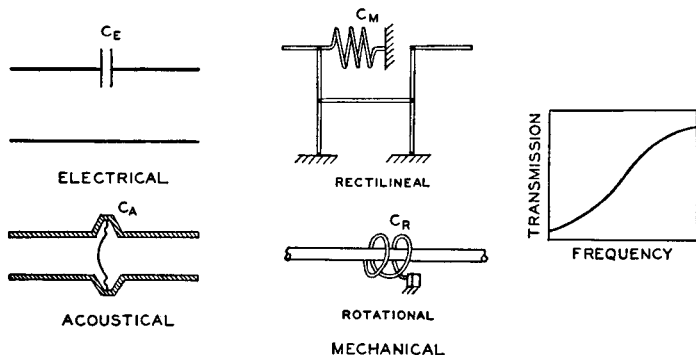

FIG. 5.9. Electrical capacitance in series with a line and the mechanical rectilinear, mechanical rotational and acoustical analogies. The graph depicts the transmission frequency characteristic.

Equation 5.48 shows that the mechanical impedance of the compliance of the mechanical rectilinear system of Fig. 5.9 is inversely proportional to the frequency. Equations 5.40 and 5.48 show that at low frequencies the input velocity to the compliance is relatively small and there will be little transmission. At high frequencies the input velocity to the compliance is relatively large and therefore it introduces very little impedance to motion. Therefore the transmission characteristic will be shown in Fig. 5.9.

The mechanical rotational impedance of Fig. 5.9 is

$$z_{R2} = \frac{1}{j\omega C_R} \quad 5.49$$

where C_R = rotational compliance, in radians per dyne per centimeter.

Equation 5.49 shows that the mechanical rotational impedance of the rotational compliance of the mechanical rotational system of Fig. 5.9 is inversely proportional to the frequency. Equations 5.41 and 5.48 show that at the low frequencies the input angular velocity to the rotational compliance is relatively small and the transmission is low. At the high frequencies the angular velocity of the rotational compliance is relatively large and it introduces very little impedance to motion. Therefore the transmission characteristic will be as shown in Fig. 5.9.

There is no simple purely acoustical system which is analogous to an electrical capacitance in series with a line. The analogy shown in Fig. 5.9 consists of a stiffness controlled diaphragm, that is, the mass of the diaphragm is small and the stiffness high so that the frequency range under consideration is well below the natural resonant frequency of the diaphragm and suspension. The acoustical capacitance of this system is

$$C_A = C_M S^2 \quad 5.50$$

where C_A = acoustical capacitance, in (centimeter)⁵ per dyne,

C_M = compliance of the suspension system, in centimeters per dyne, and

S = area of the diaphragm, in square centimeters.

The acoustical impedance of Fig. 5.9 is

$$z_{A2} = \frac{1}{j\omega C_A} \quad 5.51$$

where C_A = acoustical capacitance of equation 5.50.

It will be seen that this system will not transmit a steady flow of a gas in the same way that the electrical circuit of Fig. 5.9 will not transmit direct current. Equation 5.51 shows that the acoustical impedance of an acoustical capacitance is inversely proportional to the frequency. Equations 5.42 and 5.51 show that the transmission will increase with increase of the frequency as shown by the characteristic of Fig. 5.9.

5.13. Inductance and Electrical Capacitance in Series with a Line and the Mechanical Rectilinear, Mechanical Rotational, and Acoustical Analogies

Fig. 5.10 shows an inductance and acoustical capacitance connected in series with a line. The mechanical rectilinear, mechanical rotational and acoustical analogies are also shown in Fig. 5.10.

The electrical impedance of the electrical network of Fig. 5.10 is

$$z_{E2} = j\omega L + \frac{1}{j\omega C_E} \quad 5.52$$

where L = inductance, in abhenries, and
 C_E = electrical capacitance, in abfarads.

The output current can be obtained from equations 5.39 and 5.52.

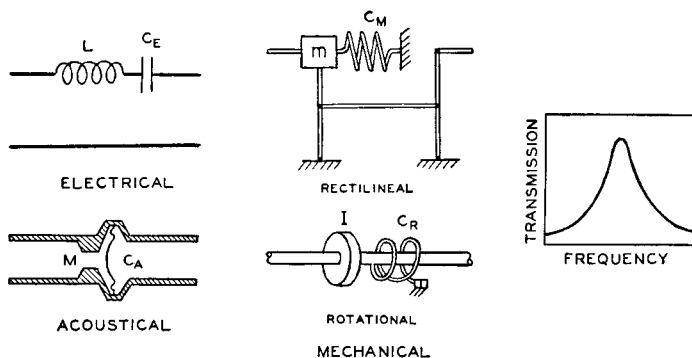

FIG. 5.10. Inductance and electrical capacitance in series with a line and the mechanical rectilinear, mechanical rotational and acoustical analogies. The graph depicts the transmission frequency characteristic.

The mechanical rectilinear impedance of the mechanical rectilinear system of Fig. 5.10 is

$$z_{M2} = j\omega m + \frac{1}{j\omega C_M} \quad 5.53$$

where m = mass, in grams, and
 C_M = compliance, in centimeters per dyne.

The output velocity can be obtained from equations 5.40 and 5.53.

The mechanical rotational impedance of the mechanical rotational system of Fig. 5.10 is

$$z_{R2} = j\omega I + \frac{1}{j\omega C_R} \quad 5.54$$

where I = moment of inertia, in gram (centimeter)², and
 C_R = rotational compliance, in radians per dyne per centimeter.

The output angular velocity can be obtained from equations 5.41 and 5.54.

The acoustical impedance of the acoustical system of Fig. 5.10 is

$$z_{A2} = j\omega M + \frac{1}{j\omega C_A} \quad 5.55$$

where M = inertance, in grams per (centimeter)⁴, and
 C_A = acoustical capacitance, in (centimeter)⁵ per dyne.

The expression for the acoustical capacitance is given by equation 5.50.

The output volume current can be obtained from equations 5.42 and 5.55.

At low frequencies the four systems behave the same as those of Fig. 5.9 and the transmission is small. At high frequencies the systems behave the same as those of Fig. 5.8, and again the transmission is small. At the resonant frequency of the inductance and electrical capacitance the electrical impedance of these two elements in series is zero and equations 5.39 and 5.52 show that the series circuit introduces no attenuation. At the resonant frequency of the mass and compliance the force required to drive the resonant system is zero and therefore the attenuation introduced by the system is zero. Equations 5.40 and 5.53 also show that the attenuation is zero at the resonant frequency of the mass and compliance. At the resonant frequency of the moment of inertia and rotational compliance the torque required to drive the resonant system is zero and therefore the attenuation introduced by the system is zero. Equations 5.41 and 5.54 also show that the attenuation is zero at the resonant frequency of the moment of inertia and rotational compliance. At the resonant frequency of the inertance and acoustical capacitance the pressure required to actuate the resonant system is zero. Equations 5.42 and 5.55 also show that the attenuation introduced by the system is zero. The transmission characteristics of the four systems are shown in Fig. 5.10.

5.14. Inductance and Electrical Capacitance in Parallel, in Series with a Line and the Mechanical Rectilinear, Mechanical Rotational and Acoustical Analogies

Fig. 5.11 shows an inductance and electrical capacitance in parallel connected in series with a line. The mechanical rectilinear, mechanical rotational and acoustical analogies are also shown in Fig. 5.11.

The electrical impedance of the electrical network of Fig. 5.11 is

$$z_{E2} = \frac{j\omega L}{1 - \omega^2 LC_E} \quad 5.56$$

where L = inductance, in abhenries, and
 C_E = electrical capacitance, in abfarads.

The output current can be obtained from equations 5.39 and 5.56.

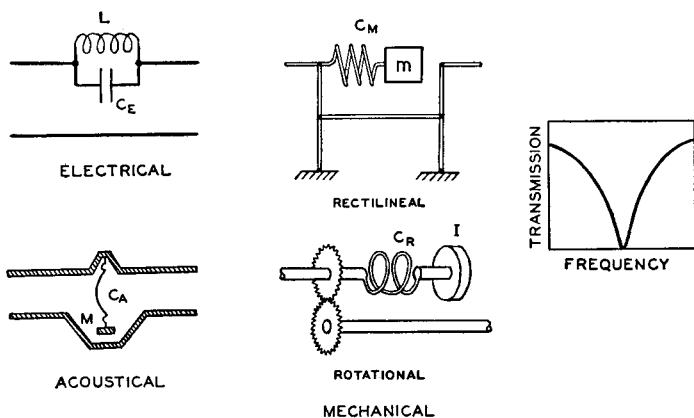

FIG. 5.11. Inductance and electrical capacitance in parallel, in series with a line and the mechanical rectilinear, mechanical rotational and acoustical analogies. The graph depicts the transmission frequency characteristic.

The mechanical rectilinear impedance of the mechanical rectilinear system of Fig. 5.11 is

$$z_{M2} = \frac{j\omega m}{1 - \omega^2 m C_M} \quad 5.57$$

where m = mass, in grams, and
 C_M = compliance, in centimeters per dyne.

The output velocity can be obtained from equations 5.40 and 5.57.

The mechanical rotational impedance of the mechanical rotational system of Fig. 5.11 is

$$z_{R2} = \frac{j\omega I}{1 - \omega^2 I C_R} \quad 5.58$$

where I = moment of inertia, in grams (centimeter)², and
 C_R = rotational compliance, in radians per dyne per centimeter.

The output angular velocity can be obtained from equations 5.41 and 5.58.

The acoustical impedance of the acoustical system of Fig. 5.11 is

$$z_{A2} = \frac{j\omega M}{1 - \omega^2 M C_A} \quad 5.59$$

where M = inertance, in grams per (centimeter)⁴, and
 C_A = acoustical capacitance, in (centimeter)⁵ per dyne.

The output volume current can be obtained from equations 5.42 and 5.59.

At low frequencies the systems behave the same as those of Fig. 5.8 and the attenuation is small. At high frequencies the systems behave the same as those of Fig. 5.9 and again the attenuation is small. At the resonant frequency of the inductance and electrical capacitance the electrical impedance is infinite and equations 5.39 and 5.56 show that there is no transmission. At the resonant frequency of the mass and compliance of Fig. 5.11 the mechanical rectilinear impedance is infinite and the input to the spring does not move. Equations 5.40 and 5.57 show that there is no transmission at this frequency. At the resonant frequency of the moment of inertia and rotational compliance of Fig. 5.11 the mechanical rotational impedance is infinite and the input to the spring does not rotate. Equations 5.41 and 5.58 show that there is no transmission at this frequency. At the resonant frequency of the inertance and acoustical capacitance of Fig. 5.11 equation 5.59 shows that the acoustical impedance is infinite. Equation 5.42 shows that there is no transmission at this frequency. The transmission characteristics of the four systems are shown in Fig. 5.11.

5.15. Electrical Resistance, Inductance and Electrical Capacitance in Series with a Line and the Mechanical Rectilinear, Mechanical Rotational and Acoustical Analogies

Fig. 5.12 shows an electrical resistance, inductance and electrical capacitance in series with a line. The mechanical rectilinear, mechanical rotational and acoustical analogies are also shown in Fig. 5.12.

The electrical impedance of the electrical network of Fig. 5.12 is

$$z_{E2} = r_E + j\omega L + \frac{1}{j\omega C_E} \tag{5.60}$$

where r_E = electrical resistance, in abohms,
 L = inductance, in abhenries, and
 C_E = capacitance, in abfarads.

The output current can be obtained from equations 5.39 and 5.60.

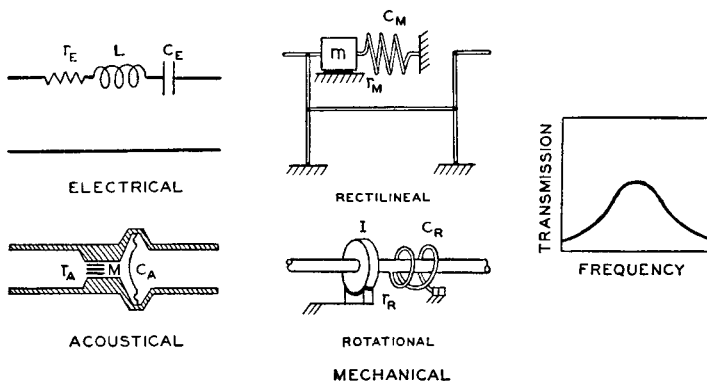

FIG. 5.12. Electrical resistance, inductance and electrical capacitance in series with a line and the mechanical rectilinear, mechanical rotational and acoustical analogies. The graph depicts the transmission frequency characteristic.

The mechanical rectilinear impedance of the mechanical system of Fig. 5.12 is

$$z_{M2} = r_M + j\omega m + \frac{1}{j\omega C_M} \tag{5.61}$$

where r_M = mechanical rectilinear resistance, in mechanical ohms,
 m = mass, in grams,
 C_M = compliance, in centimeters per dyne.

The output velocity can be obtained from equations 5.40 and 5.61.

The mechanical rotational impedance of the mechanical rotational system is

$$z_{R2} = r_R + j\omega I + \frac{1}{j\omega C_R} \tag{5.62}$$

where r_R = mechanical rotational resistance, in rotational ohms,
 I = moment of inertia, in gram (centimeter)², and
 C_R = rotational compliance, in radians per dyne per centimeter.

The output rotational velocity can be obtained from equations 5.41 and 5.62.

The acoustical impedance of the acoustical system of Fig. 5.12 is

$$z_{A2} = r_A + j\omega M + \frac{1}{j\omega C_A} \quad 5.63$$

where r_A = acoustical resistance, in acoustical ohms,
 M = inertance, in grams per (centimeter)⁴, and
 C_A = acoustical capacitance, in (centimeter)⁵ per dyne.

The output volume current can be obtained from equations 5.42 and 5.63.

At low frequencies the four systems behave the same as those of Fig. 5.9 and the transmission is small. At high frequencies the systems behave the same as those of Fig. 5.8, and again the transmission is small. At the resonant frequency of the inductance and electrical capacitance the series electrical reactance is zero. Therefore, from equations 5.39 and 5.60 the attenuation is due to the electrical resistance. At the resonant frequency of the mass and compliance, Fig. 5.12, the mechanical rectilinear reactance is zero. Therefore, from equations 5.40 and 5.61 the attenuation is due to the mechanical resistance. At the resonant frequency of the moment of inertia and the rotational compliance, Fig. 5.12, the mechanical rotational reactance is zero. Therefore, from equations 5.41 and 5.62 the attenuation is due to the mechanical rotational resistance. At the resonant frequency of the inertance and acoustical capacitance, Fig. 5.12, the acoustical reactance is zero. Therefore, from equations 5.42 and 5.63 the attenuation is due to the acoustical resistance. The transmission characteristic of these systems is shown in Fig. 5.12. This characteristic at the low and high frequencies is the same as that of Fig. 5.10. However, in the region of resonance the resistance in each of the four systems introduces attenuation as depicted by the transmission characteristic of Fig. 5.12.

5.16. Electrical Resistance, Inductance and Electrical Capacitance in Parallel, in Series with a Line and the Mechanical Rectilinear, Mechanical Rotational and Acoustical Analogies

Fig. 5.13 shows an electrical resistance, inductance and electrical capacitance in parallel in series with a line. The mechanical rectilinear,

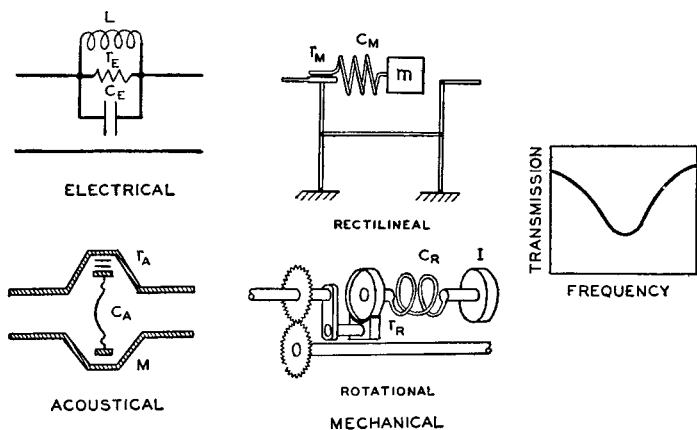

FIG. 5.13. Electrical resistance, inductance and electrical capacitance in parallel, in series with a line and the mechanical rectilinear, mechanical rotational and acoustical analogies. The graph depicts the transmission frequency characteristic.

mechanical rotational and acoustical analogies are also shown in Fig. 5.13. The electrical impedance of the electrical network of Fig. 5.13 is

$$z_{E2} = \frac{j\omega r_E L}{r_E - \omega^2 r_E L C_E + j\omega L} \tag{5.64}$$

where r_E = electrical resistance, in abohms,
 L = inductance, in abhenries, and
 C_E = electrical capacitance, in abfarads.

The output current can be obtained from equations 5.39 and 5.64.

The mechanical rectilinear impedance of the mechanical rectilinear system of Fig. 5.13 is

$$z_{M2} = \frac{j\omega r_M m}{r_M - \omega^2 r_M C_M + j\omega m} \tag{5.65}$$

where r_M = mechanical rectilinear resistance, in mechanical ohms,
 m = mass, in grams, and
 C_M = compliance, in centimeters per dyne.

The output velocity can be obtained from equations 5.40 and 5.65.

The mechanical rotational impedance of the mechanical rotational system of Fig. 5.13 is

$$z_{R2} = \frac{j\omega r_R I}{r_R - \omega^2 r_R I C_R + j\omega I} \quad 5.66$$

where r_R = mechanical rotational resistance, in rotational ohms,
 I = moment of inertia in gram (centimeter)², and
 C_R = rotational compliance, in radians per dyne per centimeter.

The output rotational velocity can be obtained from equations 5.41 and 5.66.

The acoustical impedance of the acoustical system of Fig. 5.13 is

$$z_{A2} = \frac{j\omega r_A M}{r_A - \omega^2 r_A M C_A + j\omega M} \quad 5.67$$

where r_A = acoustical resistance, in acoustical ohms,
 M = inertance, in grams per (centimeter)⁴, and
 C_A = acoustical capacitance, in (centimeter)⁵ per dyne.

The output volume current can be obtained from equations 5.42 and 5.67.

At low frequencies the systems behave the same as those of Fig. 5.8 and the attenuation is small. At high frequencies the systems behave the same as those of Fig. 5.9 and the attenuation is small. At the resonant frequency of the inductance and electrical capacitance the electrical reactance is infinite and, therefore, from equations 5.39 and 5.64 the attenuation is due to the electrical resistance. At the resonant frequency of the mass and compliance, Fig. 5.13, the mechanical rectilinear reactance is infinite. Therefore, from equations 5.40 and 5.65 the attenuation is due to the mechanical rectilinear resistance. At the resonant frequency of the moment of inertia and the rotational compliance, Fig. 5.13, the mechanical rotational impedance is infinite. Therefore, from equations 5.41 and 5.66 the attenuation is due to the mechanical rotational resistance. At the resonant frequency of the inertance and acoustical capacitance, Fig. 5.13, the acoustical reactance is infinite. Therefore, from

equations 5.42 and 5.67 the attenuation is due to the acoustical resistance. The transmission characteristic of these systems is shown in Fig. 5.13. This characteristic at the low and high frequencies is the same as that of Fig. 5.11. However, in the region of resonance the resistance in each of the four systems decreases the attenuation as depicted by the transmission characteristic of Fig. 5.13.

5.17. Resistance Networks

The use of resistance networks in electrical circuits is well known. Series and shunt networks are employed to introduce dissipation or attenuation in the electrical circuits. In the same way mechanical and acoustical resistance may be used in these systems to introduce dissipation, damping or attenuation. "T" and " π " networks are a combination of series and shunt elements usually employed to introduce attenuation without mismatching impedances or for matching dissimilar impedances.

5.18. Electrical Resistance in Series with a Line and the Mechanical Rectilinear, Mechanical Rotational, and Acoustical Analogies

Fig. 5.14 shows an electrical resistance in series with a line. Referring to equation 5.39 it will be seen that the attenuation will be greater as the

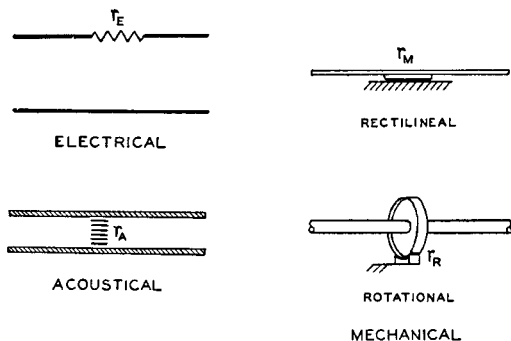

FIG. 5.14. Electrical resistance in series with a line and the mechanical rectilinear, mechanical rotational and acoustical analogies.

resistance is made larger. Equation 5.40 shows that in the same way the attenuation in the mechanical rectilinear system of Fig. 5.14 will be greater as the sliding resistance is made larger. Equation 5.41 shows that the attenuation in the mechanical rotational system of Fig. 5.14 will be

greater as the sliding resistance on the brake wheel is made larger. The acoustical system of Fig. 5.14 shows a system of slits in series with input and output acoustical impedances. Equation 5.42 shows that the attenuation in this system will increase as the acoustic resistance is made larger.

5.19. Electrical Resistance in Shunt with a Line and the Mechanical Rectilinear, Mechanical Rotational and Acoustical Analogies

Fig. 5.15 shows an electrical resistance in shunt with a line. Referring to equation 5.11 it will be seen that the attenuation in this case will be

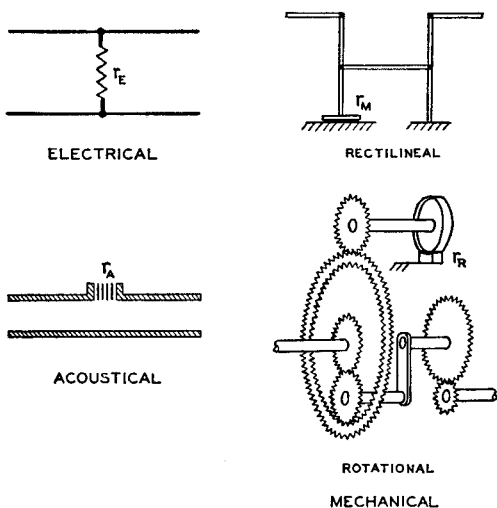

FIG. 5.15. Electrical resistance in shunt with a line and the mechanical rectilinear, mechanical rotational and acoustical analogies.

greater as the electrical resistance is made smaller. Equation 5.12 shows that in the same way the attenuation in the mechanical rectilinear system of Fig. 5.15 will be greater as the sliding resistance is made smaller. Equation 5.13 shows that the attenuation in the mechanical rotational system of Fig. 5.15 will be greater as the sliding resistance on the brake wheel is made smaller. Equation 5.14 shows that in the acoustical system of Fig. 5.15 the attenuation will increase as the shunt acoustical resistance is made smaller.

5.20. “T” Type Electrical Resistance Network and the Mechanical Rectilinear, Mechanical Rotational and Acoustical Analogies

A “T” type electrical network is shown in Fig. 5.16. Equation 5.11 is applicable by considering r_{E1} to be added to z_{E1} and r_{E1} to be added to z_{E3} . r_{E2} is z_{E2} in equation 5.11. In the same way equations 5.12, 5.13 and 5.14 apply to the mechanical rectilinear, mechanical rotational, and

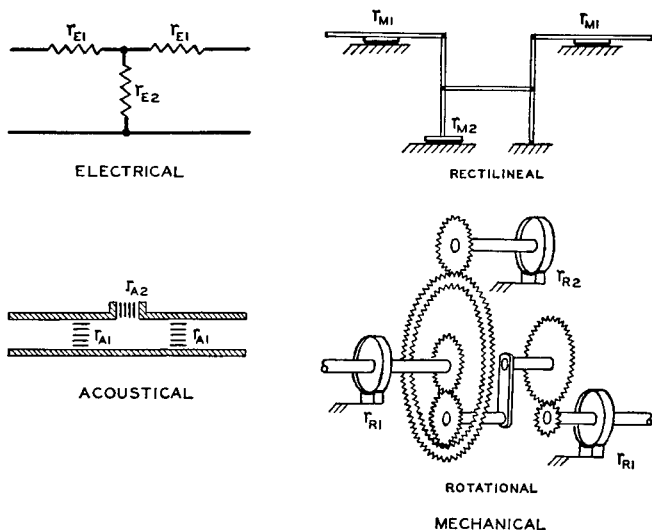

FIG. 5.16. “T” type electrical resistance network and the mechanical rectilinear, mechanical rotational and acoustical analogies.

acoustical systems of Fig. 5.16, wherein z_{M1} , z_{R1} , and z_{A1} is the sum of r_{M1} , r_{R1} , and r_{A1} and the input impedances, respectively, and z_{M3} , z_{R3} , and z_{A3} is the sum of r_{M1} , r_{R1} , and r_{A1} and the output impedances, respectively.

5.21. “ π ” Type Electrical Resistance Network and the Mechanical Rectilinear, Mechanical Rotational and Acoustical Analogies

A “ π ” type electrical network is shown in Fig. 5.17. The “ π ” type of electrical network may be used for the same purpose as the “T” network of the preceding section. The mechanical rectilinear, mechanical rotational, and acoustical resistance systems equivalent to the electrical “ π ”

network are shown in Fig. 5.17. Equation 5.11 may be used to predict the performance of the electrical system. In this case z_{E1} is the input impedance, z_{E2} is r_{E2} , and z_{E3} is r_{E1} in series with r_{E2} in parallel with the output impedance. This of course determines only the current in z_{E3} . This current is equal to the vector sum of the current in r_{E2} and the

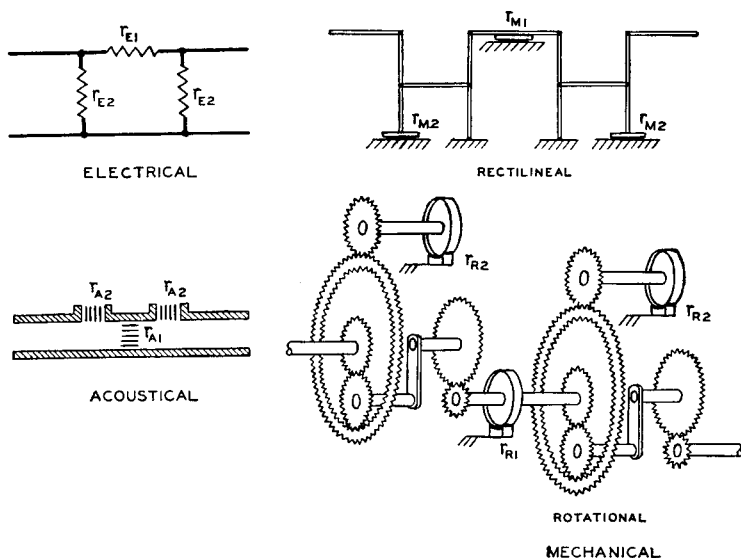

FIG. 5.17. " π " type electrical resistance network and the mechanical rectilinear, mechanical rotational and acoustical analogies.

output impedance. The performance of the mechanical rectilinear, mechanical rotational, and acoustical systems may be obtained by similar considerations employing equations 5.12, 5.13 and 5.14.

5.22. Electrical, Mechanical Rectilinear, Mechanical Rotational and Acoustical Transformers

A transformer is a transducer used for transferring between two impedances of different values without appreciable reflection loss. Electrical, mechanical rectilinear, mechanical rotational and acoustical transformers are shown in Fig. 5.18.

In the ideal electrical transformer of Fig. 5.18 the electromotive force, current and electrical impedance ratios on the two sides of the transformer are

$$e_2 = \frac{N_2}{N_1} e_1 \tag{5.68}$$

$$i_2 = \frac{N_1}{N_2} i_1 \tag{5.69}$$

$$z_{E2} = \left(\frac{N_2}{N_1}\right)^2 z_{E1} \tag{5.70}$$

where N_1 = number of turns in the primary, and
 N_2 = number of turns on the secondary.

e_1 , i_1 , and z_{E1} represent the electromotive force, current and electrical impedance on the primary side and e_2 , i_2 and z_{E2} represent the electromotive force current and electrical impedance on the secondary side.

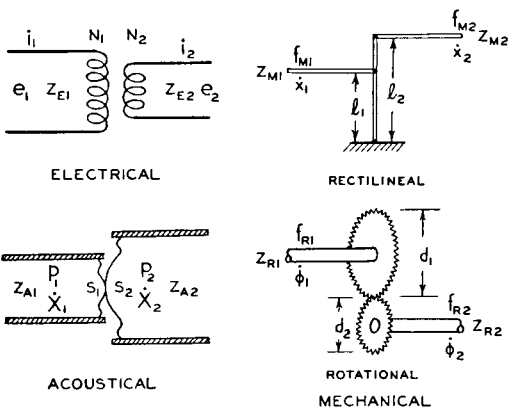

FIG. 5.18. Electrical, mechanical rectilinear, mechanical rotational and acoustical transformers.

The mechanical rectilinear transformer of Fig. 5.18 consists of a rigid massless lever with frictionless bearings. The force, velocity and

mechanical rectilinear impedance ratios on the two sides of the lever are

$$f_{M2} = \frac{l_1}{l_2} f_{M1} \quad 5.71$$

$$\dot{x}_2 = \frac{l_2}{l_1} \dot{x}_1 \quad 5.72$$

$$z_{M2} = \left(\frac{l_1}{l_2}\right)^2 z_{M1} \quad 5.73$$

l_1 and l_2 are the lengths of the lever arms depicted in Fig. 5.18. f_{M1} , \dot{x}_1 and z_{M1} and f_{M2} , \dot{x}_2 and z_{M2} represents the force, velocity and mechanical rectilinear impedance on the two sides of the mechanical transformer.

The mechanical rotational transformer, of Fig. 5.18, consists of a massless rigid gear train. The torque, angular velocity and mechanical rotational impedance on the two sides of the gear train are

$$f_{R2} = \frac{d_2}{d_1} f_{R1} \quad 5.74$$

$$\dot{\phi}_2 = \frac{d_1}{d_2} \dot{\phi}_1 \quad 5.75$$

$$z_{R2} = \left(\frac{d_2}{d_1}\right)^2 z_{R1} \quad 5.76$$

d_1 and d_2 are the diameters of the gears depicted in Fig. 5.18. f_{R1} , $\dot{\phi}_1$ and z_{R1} and f_{R2} , $\dot{\phi}_2$ and z_{R2} represents the torque, angular velocity and mechanical rotational impedance on the two sides of the rotational transformer.

The acoustical transformer consists of two rigid massless diaphragms with negligible suspension stiffness coupled together as shown in Fig. 5.18. The pressure, volume current and acoustical impedance on the two sides of the diaphragm combination are

$$p_2 = \frac{S_1}{S_2} p_1 \quad 5.77$$

$$\dot{X}_2 = \frac{S_2}{S_1} \dot{X}_1 \quad 5.78$$

$$z_{A2} = \left(\frac{S_1}{S_2}\right)^2 z_{A1} \quad 5.79$$

S_1 and S_2 are the areas of the two diaphragms. p_1 , \dot{X}_1 and z_{A1} and p_2 , \dot{X}_2 and z_{A2} represents the pressure, volume current and acoustical impedance on the two sides of the acoustical transformer.

The acoustical transformer of Fig. 5.18 is not purely an acoustical system since it uses mechanical elements in the form of diaphragms. In an acoustical system a horn may be used to transfer from one impedance to another impedance of a different value without appreciable reflection loss. As a matter of fact a horn⁶ may be looked upon as an acoustical transformer, transforming large pressures and small volume currents to small pressures and large volume currents or the reverse process.

⁶ For these and other properties of horns see Olson, "Elements of Acoustical Engineering," D. Van Nostrand Co., New York, 1940.

CHAPTER VI

WAVE FILTERS

6.1. Introduction

The essential function of a wave filter is to let pass desired frequency bands and to highly attenuate neighboring undesired frequency bands. An electrical filter is a general type of electrical network in which a number of recurrent electrical impedance elements are assembled to form a recurrent structure. Electrical networks of this sort are called electrical wave filters,¹ as they pass certain frequencies freely and stop others. Wave filters analogous to electrical wave filters may be developed and employed in any wave motion system. Acoustical² and mechanical wave filters are becoming very important for use in noise reduction and control of vibrations in all types of vibrating systems. A number of books and numerous articles have been published on electrical wave filters. Therefore it is important to establish the analogies between electrical, mechanical and acoustical wave filters so that the information on electrical wave filters may be used to solve filter problems in mechanical and acoustical systems. It is the purpose of this chapter to illustrate and describe the different types of electrical, mechanical rectilinear, mechanical rotational and acoustical wave filters.

6.2. Types of Wave Filters

The response characteristics of wave filters are widely different. The more frequently used types are designated as follows:

- Low Pass Wave Filters
- High Pass Wave Filters
- Band Pass Wave Filters
- Band Elimination Wave Filters

¹ Campbell, G. A., *Bell System Tech. Jour.*, Vol. I, No. 2, 1922.

² Stewart, G. W., *Phys. Rev.*, Vol. 20, No. 6, p. 528, 1922.

A low pass wave filter is a system which passes currents, velocities, angular velocities or volume currents of all frequencies from zero up to a certain frequency termed the cutoff frequency f_c and which bars currents, velocities, angular velocities and volume currents of all higher frequencies.

A high pass wave filter is a system which passes currents, velocities, angular velocities or volume currents of all frequencies from infinity down to a certain frequency termed the cutoff frequency f_c and which bars currents, velocities, angular velocities and volume currents of all lower frequencies.

A band pass wave filter is a system which passes currents, velocities, angular velocities or volume currents that lie between two cutoff frequencies f_{c1} and f_{c2} and bars currents, velocities, angular velocities and volume currents of all frequencies outside this range.

A band elimination wave filter is a system which bars currents, velocities, angular velocities or volume currents that lie between the two cutoff frequencies f_{c1} and f_{c2} and passes currents, velocities, angular velocities and volume currents of all frequencies outside this range.

6.3. Response Characteristics of Wave Filters^{3, 4}

The ideal or non-dissipative filters consist entirely of pure reactances. The primary object is the determination of those combinations of reactances which will give a single or double transmitted band of frequencies. The most important type of structure is the ladder type, that is, a certain combination of reactances in series with the line and another combination in shunt with the line. The series reactance and shunt reactance are designated by z_1 and z_2 , respectively. It has been shown in treatises on wave filters that attenuation occurs when z_1/z_2 is positive and when z_1/z_2 is negative and no greater in absolute magnitude than four. Non-attenuation occurs when z_1/z_2 is negative and is less in absolute magnitude than four. Therefore, a non-dissipative recurrent structure of the ladder type having series impedances z_1 and shunt impedances z_2 will pass readily only currents of such frequencies as will make the ratio z_1/z_2 lie between 0 and -4 .

³ Johnson, "Transmission Circuits for Telephonic Communication," D. Van Nostrand Co., New York.

⁴ Shea, "Transmission Networks and Wave Filters," D. Van Nostrand Co., New York.

6.4. Low Pass Wave Filters

Electrical, mechanical rectilinear, mechanical rotational and acoustical low pass filters are shown in Fig. 6.1.

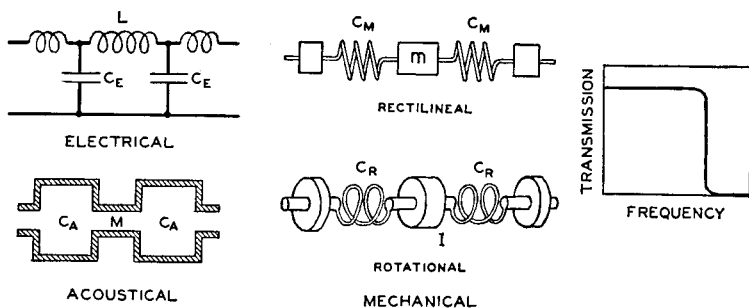

FIG. 6.1. Electrical, mechanical rectilinear, mechanical rotational and acoustical low pass wave filters.

The impedance of the series arm in the four systems is

$$z_{E1} = j\omega L \quad 6.1$$

$$z_{M1} = j\omega m \quad 6.2$$

$$z_{R1} = j\omega I \quad 6.3$$

$$z_{A1} = j\omega M \quad 6.4$$

The impedance of the shunt arm in the four systems is

$$z_{E2} = \frac{1}{j\omega C_E} \quad 6.5$$

$$z_{M2} = \frac{1}{j\omega C_M} \quad 6.6$$

$$z_{R2} = \frac{1}{j\omega C_R} \quad 6.7$$

$$z_{A2} = \frac{1}{j\omega C_A} \quad 6.8$$

The limiting frequencies are given by

$$\frac{z_1}{z_2} = 0 \quad \text{and} \quad \frac{z_1}{z_2} = -4 \quad 6.9$$

From the constants of the systems,

$$\frac{z_{E1}}{z_{E2}} = LC_E \omega_C^2 = 0, \quad \text{when } \omega_C = 0 \quad 6.10$$

$$\frac{z_{M1}}{z_{M2}} = mC_M \omega_C^2 = 0, \quad \text{when } \omega_C = 0 \quad 6.11$$

$$\frac{z_{R1}}{z_{R2}} = IC_R \omega_C^2 = 0, \quad \text{when } \omega_C = 0 \quad 6.12$$

$$\frac{z_{A1}}{z_{A2}} = MC_A \omega_C^2 = 0, \quad \text{when } \omega_C = 0 \quad 6.13$$

$$\frac{z_{E1}}{z_{E2}} = -LC_E \omega_C^2 = -4, \quad \text{when } \omega_C = \frac{2}{\sqrt{LC_E}} \quad 6.14$$

$$\frac{z_{M1}}{z_{M2}} = -mC_M \omega_C^2 = -4, \quad \text{when } \omega_C = \frac{2}{\sqrt{mC_M}} \quad 6.15$$

$$\frac{z_{R1}}{z_{R2}} = -IC_R \omega_C^2 = -4, \quad \text{when } \omega_C = \frac{2}{\sqrt{IC_R}} \quad 6.16$$

$$\frac{z_{A1}}{z_{A2}} = -MC_A \omega_C^2 = -4, \quad \text{when } \omega_C = \frac{2}{\sqrt{MC_A}} \quad 6.17$$

Equations 6.10 and 6.17, inclusive, show that the systems of Fig. 6.1 are low pass filters transmitting currents, linear velocities, angular velocities or volume currents of all frequencies lying between 0 and the cutoff frequency f_C where $f_C = \omega_C/2\pi$.

6.5. High Pass Wave Filters

Electrical, mechanical rectilinear, mechanical rotational, and acoustical high pass wave filters are shown in Fig. 6.2.

The impedance of the series arm in the four systems is

$$z_{E1} = \frac{1}{j\omega C_E} \quad 6.18$$

$$z_{M1} = \frac{1}{j\omega C_M} \quad 6.19$$

$$z_{R1} = \frac{1}{j\omega C_R} \quad 6.20$$

$$z_{A1} = \frac{1}{j\omega C_A} \quad 6.21$$

For a description of the acoustical capacitance C_A see Sec. 5.12.

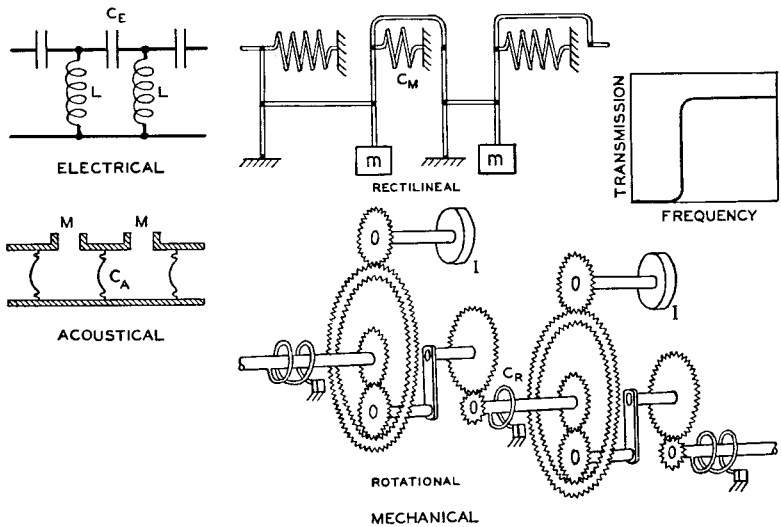

FIG. 6.2. Electrical, mechanical rectilinear, mechanical rotational and acoustical high pass wave filters.

The impedance of the shunt arm in the four systems is

$$z_{E2} = j\omega L \quad 6.22$$

$$z_{M2} = j\omega m \quad 6.23$$

$$z_{R2} = j\omega I \quad 6.24$$

$$z_{A2} = j\omega M \quad 6.25$$

The limiting frequencies are given by

$$\frac{z_1}{z_2} = 0 \quad \text{and} \quad \frac{z_1}{z_2} = -4 \quad 6.26$$

From the constants of the systems,

$$\frac{z_{E1}}{z_{E2}} = -\frac{1}{LC_E\omega_C^2} = 0, \quad \text{when } \omega_C = \infty \quad 6.27$$

$$\frac{z_{M1}}{z_{M2}} = -\frac{1}{mC_M\omega_C^2} = 0, \quad \text{when } \omega_C = \infty \quad 6.28$$

$$\frac{z_{R1}}{z_{R2}} = -\frac{1}{IC_R\omega_C^2} = 0, \quad \text{when } \omega_C = \infty \quad 6.29$$

$$\frac{z_{A1}}{z_{A2}} = -\frac{1}{MC_A\omega_C^2} = 0, \quad \text{when } \omega_C = \infty \quad 6.30$$

$$\frac{z_{E1}}{z_{E2}} = -\frac{1}{LC_E\omega_C^2} = -4, \quad \text{when } \omega_C = \frac{1}{2\sqrt{LC_E}} \quad 6.31$$

$$\frac{z_{M1}}{z_{M2}} = -\frac{1}{mC_M\omega_C^2} = -4, \quad \text{when } \omega_C = \frac{1}{2\sqrt{mC_M}} \quad 6.32$$

$$\frac{z_{R1}}{z_{R2}} = -\frac{1}{IC_R\omega_C^2} = -4, \quad \text{when } \omega_C = \frac{1}{2\sqrt{IC_R}} \quad 6.33$$

$$\frac{z_{A1}}{z_{A2}} = -\frac{1}{MC_A\omega_C^2} = -4, \quad \text{when } \omega_C = \frac{1}{2\sqrt{MC_A}} \quad 6.34$$

Equations 6.27 and 6.34, inclusive, show the systems of Fig. 6.2 are high pass wave filters transmitting currents, linear velocities, angular velocities or volume currents of all frequencies lying between the cutoff frequency f_C where $f_C = \omega_C/2\pi$, and infinity.

6.6 Band Pass Wave Filters

Electrical, mechanical rectilinear, mechanical rotational, and acoustical band pass wave filters are shown in Fig. 6.3.

The impedance of the series arm in the four systems is

$$z_{E1} = j\omega L_1 + \frac{1}{j\omega C_{E1}} \quad 6.35$$

$$z_{M1} = j\omega m_1 + \frac{1}{j\omega C_{M1}} \quad 6.36$$

$$z_{R1} = j\omega I_1 + \frac{1}{j\omega C_{R1}} \quad 6.37$$

$$z_{A1} = j\omega M_1 + \frac{1}{j\omega C_{A1}} \quad 6.38$$

For a description of the acoustical capacitance C_{A1} see Sec. 5.12.

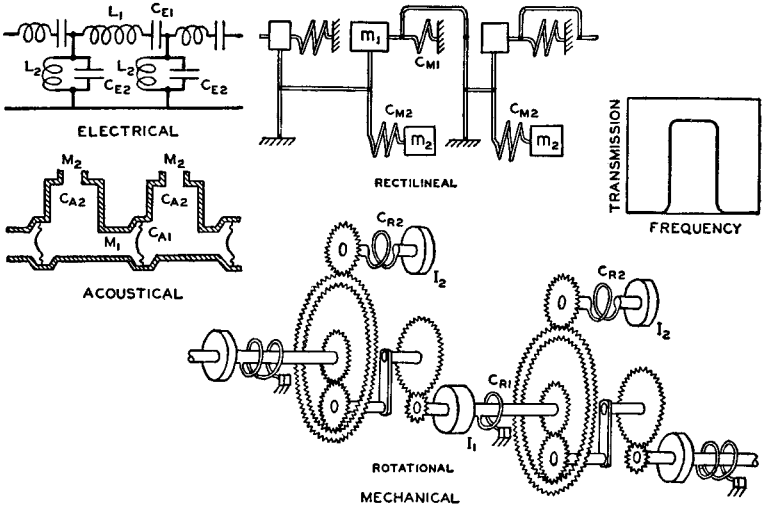

FIG. 6.3. Electrical, mechanical rectilinear, mechanical rotational and acoustical band pass wave filters.

The impedance of the shunt arm in the four systems is

$$z_{E2} = \frac{j\omega L_2}{1 - \omega^2 C_{E2} L_2} \quad 6.39$$

$$z_{M2} = \frac{j\omega m_2}{1 - \omega^2 C_{M2} m_2} \quad 6.40$$

$$z_{R2} = \frac{j\omega I_2}{1 - \omega^2 C_{R2} I_2} \quad 6.41$$

$$z_{A2} = \frac{j\omega M_2}{1 - \omega^2 C_{A2} M_2} \quad 6.42$$

The limiting frequencies are given by

$$\frac{z_1}{z_2} = 0 \quad \text{and} \quad \frac{z_1}{z_2} = -4 \quad 6.43$$

Let

$$L_1 C_{E1} = L_2 C_{E2} \quad 6.44$$

$$m_1 C_{M1} = m_2 C_{M2} \quad 6.45$$

$$I_1 C_{R1} = I_2 C_{R2} \quad 6.46$$

$$M_1 C_{A1} = M_2 C_{A2} \quad 6.47$$

$$\frac{z_{E1}}{z_{E2}} = 0, \quad \text{when } \omega_{C1} = \frac{1}{\sqrt{L_1 C_{E1}}} = \frac{1}{\sqrt{L_2 C_{E2}}} \quad 6.48$$

$$\frac{z_{M1}}{z_{M2}} = 0, \quad \text{when } \omega_{C1} = \frac{1}{\sqrt{m_1 C_{M1}}} = \frac{1}{\sqrt{m_2 C_{M2}}} \quad 6.49$$

$$\frac{z_{R1}}{z_{R2}} = 0, \quad \text{when } \omega_{C1} = \frac{1}{\sqrt{I_1 C_{R1}}} = \frac{1}{\sqrt{I_2 C_{R2}}} \quad 6.50$$

$$\frac{z_{A1}}{z_{A2}} = 0, \quad \text{when } \omega_{C1} = \frac{1}{\sqrt{M_1 C_{A1}}} = \frac{1}{\sqrt{M_2 C_{A2}}} \quad 6.51$$

$$\frac{z_{E1}}{z_{E2}} = -4, \quad \text{when } \frac{(1 - \omega_{C2}^2 L_1 C_{E1})^2}{\omega_{C2}^2 L_2 C_{E1}} = 4,$$

or

$$\omega_{C2} = \left[\sqrt{\frac{1}{L_1 C_{E2}} + \frac{1}{L_1 C_{E1}} \pm \frac{1}{\sqrt{L_1 C_{E2}}}} \right] \quad 6.52$$

$$\frac{z_{M1}}{z_{M2}} = -4, \quad \text{when } \frac{(1 - \omega_{C2}^2 m_1 C_{M1})^2}{\omega_{C2}^2 m_2 C_{M1}} = 4,$$

or

$$\omega_{C2} = \left[\sqrt{\frac{1}{m_1 C_{M2}} + \frac{1}{m_1 C_{M1}}} \pm \frac{1}{\sqrt{m_1 C_{M2}}} \right] \quad 6.53$$

$$\frac{z_{R1}}{z_{R2}} = -4, \quad \text{when} \quad \frac{(1 - \omega_{C2}^2 I_1 C_{R1})^2}{\omega_{C2}^2 I_2 C_{R1}} = 4,$$

or

$$\omega_{C2} = \left[\sqrt{\frac{1}{I_1 C_{R2}} + \frac{1}{I_1 C_{R1}}} \pm \frac{1}{\sqrt{I_1 C_{R2}}} \right] \quad 6.54$$

$$\frac{z_{A1}}{z_{A2}} = -4, \quad \text{when} \quad \frac{(1 - \omega_{C2}^2 M_1 C_{A1})^2}{\omega_{C2}^2 M_2 C_{A1}} = 4,$$

or

$$\omega_{C2} = \left[\sqrt{\frac{1}{M_1 C_{A2}} + \frac{1}{M_1 C_{A1}}} \pm \frac{1}{\sqrt{M_1 C_{A2}}} \right] \quad 6.55$$

It will be noted that ω_{C2} has two values, one greater than ω_{C1} and one less than ω_{C1} . Therefore, the upper and lower cutoff frequencies are given by

$$\omega_{C2}' = \left[\sqrt{\frac{1}{L_1 C_{E2}} + \frac{1}{L_1 C_{E1}}} - \frac{1}{\sqrt{L_1 C_{E2}}} \right], \quad 6.56$$

and

$$\omega_{C2}'' = \left[\sqrt{\frac{1}{L_1 C_{E2}} + \frac{1}{L_1 C_{E1}}} + \frac{1}{\sqrt{L_1 C_{E2}}} \right] \quad 6.57$$

$$\omega_{C2}' = \left[\sqrt{\frac{1}{m_1 C_{M2}} + \frac{1}{m_1 C_{M1}}} - \frac{1}{\sqrt{m_1 C_{M2}}} \right], \quad 6.58$$

and

$$\omega_{C2}'' = \left[\sqrt{\frac{1}{m_1 C_{M2}} + \frac{1}{m_1 C_{M1}}} + \frac{1}{\sqrt{m_1 C_{M2}}} \right] \quad 6.59$$

$$\omega_{C2}' = \left[\sqrt{\frac{1}{I_1 C_{R2}} + \frac{1}{I_1 C_{R1}}} - \frac{1}{\sqrt{I_1 C_{R2}}} \right], \quad 6.60$$

and

$$\omega_{C2''} = \left[\sqrt{\frac{1}{I_1 C_{R2}} + \frac{1}{I_1 C_{R1}} + \frac{1}{\sqrt{I_1 C_{R2}}}} \right] \quad 6.61$$

$$\omega_{C2'} = \left[\sqrt{\frac{1}{M_1 C_{A2}} + \frac{1}{M_1 C_{A1}} - \frac{1}{\sqrt{M_1 C_{A2}}}} \right], \quad 6.62$$

and

$$\omega_{C2''} = \left[\sqrt{\frac{1}{M_1 C_{A2}} + \frac{1}{M_1 C_{A1}} + \frac{1}{\sqrt{M_1 C_{A2}}}} \right] \quad 6.63$$

Equations 6.56 to 6.63, inclusive, show that the systems of Fig. 6.3 are band pass filters transmitting currents, linear velocities, angular velocities or volume currents of all frequencies lying between two cutoff frequencies $f_{C2'}$ and $f_{C2''}$, where $f_{C2'} = \omega_{C2'}/2\pi$ and $f_{C2''} = \omega_{C2''}/2\pi$.

6.7. Band Elimination Wave Filters

Electrical, mechanical rectilinear, mechanical rotational and acoustical band elimination wave filters are shown in Fig. 6.4.

The impedance of the series arm in the four systems is

$$z_{E1} = \frac{j\omega L_1}{1 - \omega^2 C_{E1} L_1} \quad 6.64$$

$$z_{M1} = \frac{j\omega m_1}{1 - \omega^2 C_{M1} m_1} \quad 6.65$$

$$z_{R1} = \frac{j\omega I_1}{1 - \omega^2 C_{R1} I_1} \quad 6.66$$

$$z_{A1} = \frac{j\omega M_1}{1 - \omega^2 C_{A1} M_1} \quad 6.67$$

The impedance of the shunt arm in the four systems is

$$z_{E2} = j\omega L_2 - \frac{j}{\omega C_{E2}} \quad 6.68$$

$$z_{M2} = j\omega m_2 - \frac{j}{\omega C_{M2}} \quad 6.69$$

$$z_{R2} = j\omega I_2 - \frac{j}{\omega C_{R2}} \tag{6.70}$$

$$z_{A2} = j\omega M_2 - \frac{j}{\omega C_{A2}} \tag{6.71}$$

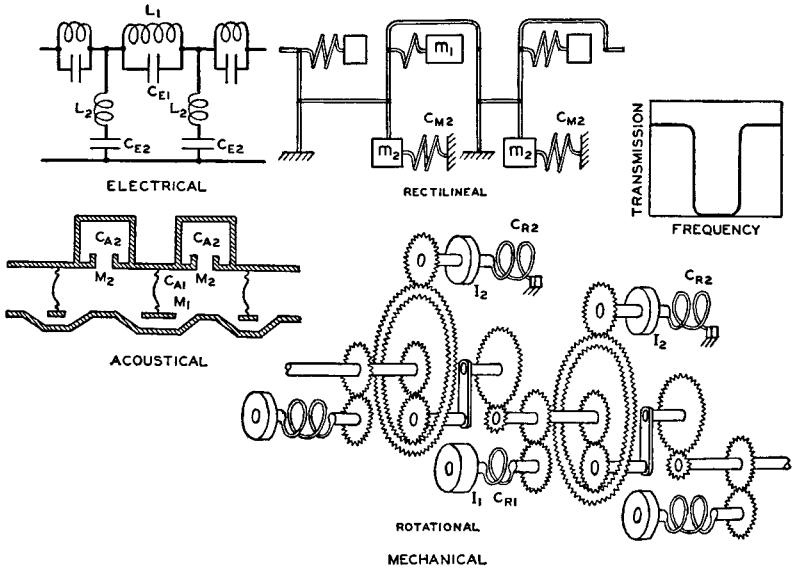

FIG. 6.4. Electrical, mechanical rectilinear, mechanical rotational and acoustical band elimination wave filters.

The limiting frequencies are given by

$$\frac{z_1}{z_2} = 0 \quad \text{and} \quad \frac{z_1}{z_2} = -4 \tag{6.72}$$

Let

$$L_1 C_{E1} = L_2 C_{E2} \tag{6.73}$$

$$m_1 C_{M1} = m_2 C_{M2} \tag{6.74}$$

$$I_1 C_{R1} = I_2 C_{R2} \tag{6.75}$$

$$M_1 C_{A1} = M_2 C_{A2} \tag{6.76}$$

$$\frac{z_{E1}}{z_{E2}} = 0, \quad \text{when } \omega_{C1} = 0 \quad \text{and} \quad \omega_{C4} = \infty \quad 6.77$$

$$\frac{z_{M1}}{z_{M2}} = 0, \quad \text{when } \omega_{C1} = 0 \quad \text{and} \quad \omega_{C4} = \infty \quad 6.78$$

$$\frac{z_{R1}}{z_{R2}} = 0, \quad \text{when } \omega_{C1} = 0 \quad \text{and} \quad \omega_{C4} = \infty \quad 6.79$$

$$\frac{z_{A1}}{z_{A2}} = 0, \quad \text{when } \omega_{C1} = 0 \quad \text{and} \quad \omega_{C4} = \infty \quad 6.80$$

Two of the limiting frequencies are determined by ω_{C1} and ω_{C4} above.

$$\frac{z_{E1}}{z_{E2}} = -4, \quad \text{when } \frac{L_1 C_{E2}}{(1 - \omega_C^2 L_1 C_{E1})^2} = 4,$$

or

$$\omega_C = \frac{\sqrt{L_1 C_{E2} + 16 L_1 C_{E1}} \pm \sqrt{L_1 C_{E2}}}{4 L_1 C_{E1}} \quad 6.81$$

$$\frac{z_{M1}}{z_{M2}} = -4, \quad \text{when } \frac{m_1 C_{M2}}{(1 - \omega_C^2 m_1 C_{M1})} = 4,$$

or

$$\omega_C = \frac{\sqrt{m_1 C_{M2} + 16 m_1 C_{M1}} \pm \sqrt{m_1 C_{M2}}}{4 m_1 C_{M1}} \quad 6.82$$

$$\frac{z_{R1}}{z_{R2}} = -4, \quad \text{when } \frac{I_1 C_{R2}}{(1 - \omega_C^2 I_1 C_{R1})} = 4,$$

or

$$\omega_C = \frac{\sqrt{I_1 C_{R2} + 16 I_1 C_{R1}} \pm \sqrt{I_1 C_{R2}}}{4 I_1 C_{R1}} \quad 6.83$$

$$\frac{z_{A1}}{z_{A2}} = -4, \quad \text{when } \frac{M_1 C_{A2}}{(1 - \omega_C^2 M_1 C_{A1})} = 4,$$

or

$$\omega_C = \frac{\sqrt{M_1 C_{A2} + 16 M_1 C_{A1}} \pm \sqrt{M_1 C_{A2}}}{4 M_1 C_{A1}} \quad 6.84$$

The other two limiting frequencies are

$$\omega_{C2} = \frac{\sqrt{L_1 C_{E2} + 16L_1 C_{E1}} - \sqrt{L_1 C_{E2}}}{4L_1 C_{E1}}, \quad 6.85$$

and

$$\omega_{C3} = \frac{\sqrt{L_1 C_{E2} + 16L_1 C_{E1}} + \sqrt{L_1 C_{E2}}}{4L_1 C_{E1}} \quad 6.86$$

$$\omega_{C2} = \frac{\sqrt{m_1 C_{M2} + 16m_1 C_{M1}} - \sqrt{m_1 C_{M2}}}{4m_1 C_{M1}}, \quad 6.87$$

and

$$\omega_{C3} = \frac{\sqrt{m_1 C_{M2} + 16m_1 C_{M1}} + \sqrt{m_1 C_{M2}}}{4m_1 C_{M1}} \quad 6.88$$

$$\omega_{C2} = \frac{\sqrt{I_1 C_{R2} + 16I_1 C_{R1}} - \sqrt{I_1 C_{R2}}}{4I_1 C_{R1}}, \quad 6.89$$

and

$$\omega_{C3} = \frac{\sqrt{I_1 C_{R2} + 16I_1 C_{R1}} + \sqrt{I_1 C_{R2}}}{4I_1 C_{R1}} \quad 6.90$$

$$\omega_{C2} = \frac{\sqrt{M_1 C_{A2} + 16M_1 C_{A1}} - \sqrt{M_1 C_{A2}}}{4M_1 C_{A1}}, \quad 6.91$$

and

$$\omega_{C3} = \frac{\sqrt{M_1 C_{A2} + 16M_1 C_{A1}} + \sqrt{M_1 C_{A2}}}{4M_1 C_{A1}} \quad 6.92$$

From equations 6.72 to 6.92, inclusive, it will be seen that the filters of Fig. 6.4 are band elimination filters transmitting currents, linear velocities, angular velocities or volume currents between the frequencies $f_{C1} = 0$ and $f_{C2} = \omega_{C2}/2\pi$, attenuating currents, linear velocities, angular velocities or volume currents between the frequencies $f_{C2} = \omega_{C2}/2\pi$ and $f_{C3} = \omega_{C3}/2\pi$, and transmitting currents, linear velocities, angular velocities or volume currents between the frequencies $f_{C3} = \omega_{C3}/2\pi$ and $f_{C4} = \infty$.

CHAPTER VII

TRANSIENTS

7.1. Introduction

Transients embrace a wide variety of physical phenomena. An electrical transient is the current which flows in a circuit following an electrical disturbance in the system. A mechanical transient is the rectilinear or angular velocity which occurs in a mechanism following a mechanical disturbance in the system. An acoustical transient is the volume current which flows in an acoustical system following an acoustical disturbance in the system. The preceding sections have been concerned with electrical, mechanical and acoustical systems in a steady state condition. The formulas and expressions assume that the systems are in a steady state condition of operation which means that the currents, linear velocities, angular velocities or volume currents have become constant direct or periodic functions of time. The steady state solution is only one part of the solution because immediately after some change in the system the currents or velocities have not settled into a steady state condition. Electrical, mechanical and acoustical systems are subjected to all types of varying and impulsive forces. Therefore, it is important to examine the behavior of these systems when subjected to impulsive forces as contrasted to steady state conditions.

The behavior of a vibrating system may be analyzed by solving the differential equations of the dynamical system. In other words find the currents or velocities of the elements which when substituted in the differential equations will satisfy the initial and final conditions. The solution of the differential equation may be divided ¹ into the steady state term and the transient term. The operational calculus is of great value in obtaining the transient response of an electrical, mechanical or acoustical system to a suddenly impressed voltage, force or pressure.

¹ Usually these parts are obtained by solving the differential equation for a particular integral and a complementary function.

The general analysis used by Heaviside is applicable to any type of vibrating system whether electrical, mechanical or acoustical. The response of a system to a unit force can be obtained with the Heaviside calculus. It is the purpose of this section to determine the response of electrical, mechanical rectilinear, mechanical rotational and acoustical systems to a suddenly applied unit electromotive force, force, torque or pressure respectively.

7.2. The Heaviside Operational Calculus ^{2, 3, 4}

Heaviside's unextended problem is as follows: given a linear dynamical system of n degrees of freedom in a state of equilibrium, find its response when a unit force is applied at any point. The unit function, **1**, depicted in Fig. 7.1, is defined to be a force which is zero for $t < 0$ and unity for $t \geq 0$.

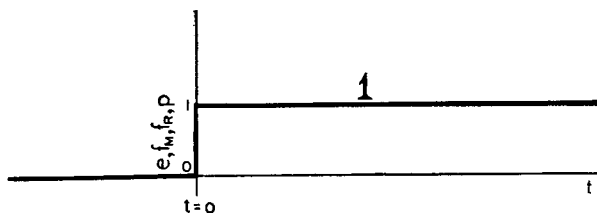

FIG. 7.1. The unit function. The electromotive force, force, torque or pressure is zero before and unity after $t = 0$.

The response of a dynamical system to a unit force is called the indicial admittance of the system. It is denoted by $A(t)$. $A(t)$ represents the current, linear velocity, angular velocity, or volume current when a unit electromotive force, force, torque or pressure is suddenly applied in a system which was initially at rest.

In the Heaviside calculus the differential equations are reduced to an algebraic form by replacing the operator d/dt by the operator p and the operation $\int dt$ by $1/p$. Tables of operational formulas have been compiled which serve for operational calculus the same purpose that tables

² Carson, "Electric Circuit Theory and Operational Calculus," McGraw-Hill Book Co., New York.

³ Bush, "Operational Circuit Analysis," John Wiley and Sons, New York.

⁴ Berg, "Heaviside's Operational Calculus," McGraw-Hill Book Co., New York.

of integrals serve the integral calculus. Operational formulas may be modified, divided or combined by various transformation schemes. This is similar to integration by parts or change of variable in the integral calculus.

The procedure in the Direct Heaviside Operational Method to be followed in obtaining an operational solution of an ordinary differential equation is as follows: Indicate differentiation with respect to the independent variable by means of the operator p . Indicate integration by means of $1/p$. Manipulate p algebraically and solve for the dependent variable in terms of p . Interpret and evaluate the solution in terms of known operators.

7.3. Transient Response of an Inductance and Electrical Resistance in Series and the Mechanical Rectilinear, Mechanical Rotational and Acoustical Analogies

The differential equation of an electromotive force, electrical resistance and inductance connected in series, as shown in Fig. 7.2, is

$$L \frac{di}{dt} + r_E i = e \quad 7.1$$

where L = inductance, in abhenries,
 r_E = electrical resistance, in abohms,
 i = current, in abamperes, and
 e = electromotive force, in abvolts.

Let the symbol p stand for the operator d/dt , then equation 7.1 becomes

$$L p i + r_E i = e \quad 7.2$$

The electrical admittance is

$$\frac{i}{e} = \frac{1}{r_E + L p} \quad 7.3$$

If $e = 0$ for $t < 0$ and unity for $t \geq 0$, then the ratio i/e is called the electrical indicial admittance designated as $A_E(t)$. The electrical indicial admittance is

$$A_E(t) = \frac{1}{r_E + L p} \mathbf{1} \quad 7.4$$

Equation 7.4 may be written

$$A_E(t) = \frac{1}{(\alpha_E + p)L} \mathbf{1} \quad 7.5$$

where $\alpha_E = r_E/L$.

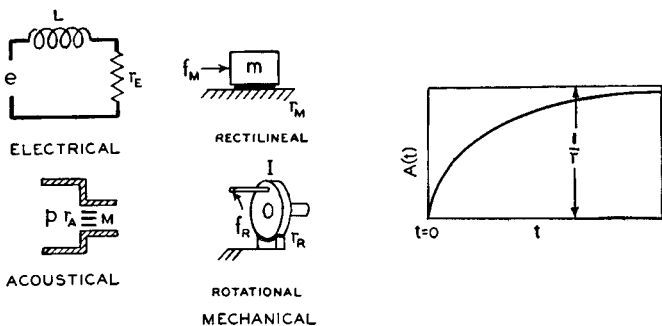

FIG. 7.2. Response of an electrical resistance and inductance in series and the analogous mechanical rectilinear, mechanical rotational and acoustical systems to a unit electromotive force, unit force, unit torque and unit pressure, respectively. The graph depicts the current, velocity, angular velocity or volume current as a function of the time for unit excitation.

From the tables of operational formulas the solution of equation 7.5 is

$$A_E(t) = \frac{1}{L\alpha_E} (1 - e^{-\alpha_E t}) \quad 7.6$$

or

$$A_E(t) = \frac{1}{r_E} (1 - e^{-\frac{r_E}{L}t}) \quad 7.7$$

The response characteristic is shown in Fig. 7.2. The current is zero for $t = 0$. The current increases for values of $t > 0$ and approaches the value $1/r_E$.

The differential equation of a force driving a mechanical rectilinear resistance and mass, as shown in Fig. 7.2, is

$$m \frac{dv}{dt} + r_M v = f_M \quad 7.8$$

where m = mass, in grams,

r_M = mechanical rectilinear resistance, in mechanical ohms,

v = linear velocity, in centimeters per second, and

f_M = driving force, in dynes.

The operational equation becomes

$$m\mathfrak{p}v + r_M v = f_M \quad 7.9$$

If $f_M = 0$ for $t = 0$ and unity for $t \geq 0$ then the ratio v/f_M is called the mechanical rectilinear indicial admittance designated as $A_M(t)$. The mechanical rectilinear indicial admittance is

$$A_M(t) = \frac{1}{r_M + m\mathfrak{p}} \mathbf{1} \quad 7.10$$

Equation 7.10 may be written

$$A_M(t) = \frac{1}{(\alpha_M + \mathfrak{p})m} \mathbf{1} \quad 7.11$$

where $\alpha_M = r_M/m$.

From the tables of operational formulas the solution is

$$A_M(t) = \frac{1}{m\alpha_M} (1 - e^{-\alpha_M t}) \quad 7.12$$

or

$$A_M(t) = \frac{1}{r_M} (1 - e^{-\frac{r_M}{m}t}) \quad 7.13$$

The response characteristic is shown in Fig. 7.2. The velocity is zero for $t = 0$. The velocity increases for values of $t > 0$ and approaches the value $1/r_M$.

The differential equation of a torque driving a mechanical rotational resistance and moment of inertia, as shown in Fig. 7.2, is

$$I \frac{d\theta}{dt} + r_R \theta = f_R \quad 7.14$$

where I = moment of inertia, in gram (centimeter)²,

r_R = mechanical rotational resistance, in rotational ohms,

θ = angular velocity, in radians per second, and

f_R = torque, in dyne centimeters.

The operational equation becomes

$$I\mathfrak{p}\theta + r_R \theta = f_R \quad 7.15$$

If $f_R = 0$ for $t < 0$ and unity for $t \geq 0$ then the ratio θ/f_R is called the mechanical rotational indicial admittance designated as $A_R(t)$.

The mechanical rotational indicial admittance is

$$A_R(t) = \frac{1}{r_R + I\dot{p}} \mathbf{1} \quad 7.16$$

Equation 7.16 may be written

$$A_R(t) = \frac{1}{(\alpha_R + \dot{p})I} \mathbf{1} \quad 7.17$$

where $\alpha_R = r_R/I$.

From the tables of operational formulas, the solution of equation 7.17 is

$$A_R(t) = \frac{1}{I\alpha_R} (1 - \epsilon^{-\alpha_R t}) \quad 7.18$$

or

$$A_R(t) = \frac{1}{r_R} (1 - \epsilon^{-\frac{r_R}{I}t}) \quad 7.19$$

The response characteristic is shown in Fig. 7.2. The angular velocity is zero for $t = 0$. The angular velocity increases for values of $t > 0$ and approaches the value $1/r_R$.

The differential equation of a sound pressure driving an acoustical resistance and inertance, as shown in Fig. 7.2, is

$$M \frac{dU}{dt} + r_A U = p \quad 7.20$$

where M = inertance, in grams per (centimeter)⁴,

r_A = acoustical resistance, in acoustical ohms,

U = volume current, in cubic centimeters, and

p = sound pressure, in dynes per square centimeter.

The operational equation becomes

$$M\dot{p}U + r_A U = p \quad 7.21$$

If $p = 0$ for $t < 0$ and unity for $t \geq 0$, then the ratio U/p is called the acoustical indicial admittance designated as $A_A(t)$.

The acoustical indicial admittance is

$$A_A(t) = \frac{1}{r_A + M\dot{p}} \mathbf{1} \quad 7.22$$

Equation 7.22 may be written,

$$A_A(t) = \frac{1}{(\alpha_A + p)M} \mathbf{1} \quad 7.23$$

where $\alpha_A = r_A/M$.

From the tables of operational formulas, the solution of equation 7.23 is

$$A_A(t) = \frac{1}{M\alpha_A} (1 - \epsilon^{-\alpha_A t}) \quad 7.24$$

or

$$A_A(t) = \frac{1}{r_A} (1 - \epsilon^{-\frac{r_A}{M}t}) \quad 7.25$$

The response characteristic is shown in Fig. 7.2. The volume current is zero for $t = 0$. The volume current increases for values of $t > 0$ and approaches the value $1/r_A$.

7.4. Transient Response of an Electrical Resistance and Electrical Capacitance in Series and the Mechanical Rectilinear, Mechanical Rotational and Acoustical Analogies

The differential equation of an electromotive force, electrical resistance and electrical capacitance connected in series, as shown in Fig. 7.3, is

$$e = r_E i + \frac{1}{C_E} \int i dt \quad 7.26$$

where $C_E =$ electrical capacitance, in abfarads,

$r_E =$ electrical resistance, in abohms,

$i =$ current, in abamperes, and

$e =$ electromotive force, in abvolts.

The electrical indicial admittance is

$$A_E(t) = \frac{pC_E}{1 + pr_EC_E} \mathbf{1} = \frac{p}{(\alpha_E + p)r_E} \mathbf{1} \quad 7.27$$

where $\alpha_E = 1/r_EC_E$.

From the table of operational formulas, the solution of equation 7.27 is

$$A_E(t) = \frac{\epsilon^{-\alpha_E t}}{r_E} = \frac{\epsilon^{-\frac{t}{r_EC_E}}}{r_E} \quad 7.28$$

The response characteristic is shown in Fig. 7.3. The current is $1/r_E$ for $t = 0$. The current decreases for values of $t > 0$ and approaches the value zero as a limit.

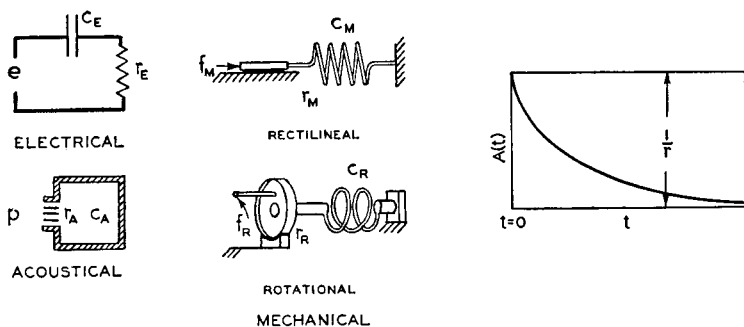

FIG. 7.3. Response of an electrical resistance and electrical capacitance in series and the analogous mechanical rectilinear, mechanical rotational and acoustical systems to a unit electromotive force, unit force, unit torque and unit pressure, respectively. The graph depicts the current, velocity, angular velocity or volume current as a function of the time for unit excitation.

The differential equation of a force driving a mechanical rectilinear resistance and compliance, as shown in Fig. 7.3, is

$$f_M = r_M v + \frac{1}{C_M} \int v dt \quad 7.29$$

where C_M = compliance, in centimeters per dyne,
 r_M = mechanical rectilinear resistance, in mechanical ohms,
 v = linear velocity, in centimeters, and
 f_M = force, in dynes.

The mechanical rectilinear admittance is

$$A_M(t) = \frac{\dot{p} C_M}{1 + \dot{p} r_M C_M} \mathbf{1} = \frac{\dot{p}}{(\alpha_M + \dot{p}) r_M} \mathbf{1} \quad 7.30$$

where $\alpha_M = 1/r_M C_M$.

From the tables of operational formulas, the solution of equation 7.30 is

$$A_M(t) = \frac{\epsilon^{-\alpha_M t}}{r_M} = \frac{\epsilon^{-\frac{t}{r_M C_M}}}{r_M} \quad 7.31$$

The response characteristic is shown in Fig. 7.3. The linear velocity is $1/r_M$ for $t = 0$. The velocity decreases for values of $t > 0$ and approaches the value zero as a limit.

The differential equation of a torque driving a mechanical rotational resistance and rotational compliance, as shown in Fig. 7.3, is

$$f_R = r_R \theta + \frac{1}{C_R} \int \theta dt \quad 7.32$$

where C_R = rotational compliance, in radians per dyne per centimeter,
 r_R = mechanical rotational resistance, in rotational ohms,
 θ = angular velocity, in radians per second, and
 f_R = torque, in dyne centimeters.

The mechanical rotational indicial admittance is

$$A_R(t) = \frac{\dot{p} C_R}{1 + \dot{p} r_R C_R} \mathbf{1} = \frac{\dot{p}}{(\alpha_R + \dot{p}) r_R} \mathbf{1} \quad 7.33$$

where $\alpha_R = 1/r_R C_R$.

From the tables of operational formulas the solution of equation 7.33 is

$$A_R(t) = \frac{\epsilon^{-\alpha_R t}}{r_R} = \frac{\epsilon^{-\frac{t}{r_R C_R}}}{r_R} \quad 7.34$$

The response characteristic is shown in Fig. 7.3. The angular velocity is $1/r_R$ for $t = 0$. The angular velocity decreases for values of $t > 0$ and approaches the value zero as a limit.

The differential equation of a sound pressure driving an acoustical resistance and an acoustical capacitance, as shown in Fig. 7.3, is

$$p = r_A U + \frac{1}{C_A} \int U dt \quad 7.35$$

where C_A = acoustical capacitance, in (centimeter)⁵ per dyne,
 r_A = acoustical resistance, in acoustical ohms,
 U = volume current, in cubic centimeters per second, and
 p = sound pressure, in dynes per square centimeter.

The acoustical indicial admittance is

$$A_A(t) = \frac{\dot{p}C_A}{1 + \dot{p}r_A C_A} \mathbf{1} = \frac{\dot{p}}{(\alpha + \dot{p})r_A} \mathbf{1} \quad 7.36$$

where $\alpha_A = 1/r_A C_A$.

From the tables of operational formulas the solution of equation 7.36 is

$$A_A(t) = \frac{\epsilon^{-\alpha_A t}}{r_A} = \frac{\epsilon^{-\frac{t}{r_A C_A}}}{r_A} \quad 7.37$$

The response characteristic is shown in Fig. 7.3. The volume current is $1/r_A$ for $t = 0$. The volume current decreases for values of $t > 0$ and approaches the value zero as a limit.

7.5. Transient Response of an Electrical Resistance, Inductance and Electrical Capacitance in Series and the Mechanical Rectilinear, Mechanical Rotational and Acoustical Analogies

The differential equation of an electromotive force, electrical resistance, inductance and electrical capacitance connected in series, as shown in Fig. 7.4, is

$$L \frac{di}{dt} + r_E i + \frac{1}{C_E} \int i dt = e \quad 7.38$$

where L = inductance, in abhenries,

r_E = electrical resistance, in abohms,

C_E = electrical capacitance, in abohms,

i = current, in abamperes, and

e = electromotive force, in abvolts.

The electrical indicial admittance is

$$A_E(t) = \frac{\dot{p}}{L\dot{p}^2 + r_E\dot{p} + \frac{1}{C_E}} \mathbf{1} \quad 7.39$$

Let

$$\alpha_E = \frac{r_E}{2L}$$

$$\omega_E = \sqrt{\frac{1}{LC_E} - \alpha_E^2}$$

The electrical indicial admittance is

$$A_E(t) = \frac{1}{L\omega_E} \frac{p\omega_E}{(p + \alpha_E)^2 + \omega_E^2} \mathbf{1} \tag{7.40}$$

From the tables of operational formulas, the solution of equation 7.40 is

$$A_E(t) = \frac{1}{L\omega_E} \epsilon^{-\alpha_E t} \sin \omega_E t \tag{7.41}$$

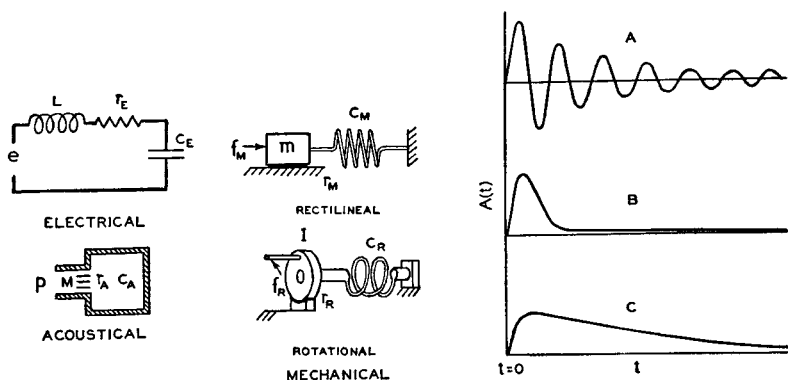

FIG. 7.4. Response of an electrical resistance, inductance and electrical capacitance in series and the analogous mechanical rectilinear, mechanical rotational and acoustical systems to a unit electromotive force, unit force, unit torque or unit pressure, respectively. The graph depicts the current, velocity, angular velocity or volume current as a function of the time for unit excitation.

The response for $r_E^2 < 4L/C_E$ is shown in Fig. 7.4A. It is a damped sinusoid.

If $r_E^2 > 4L/C_E$, then the solution becomes

$$A_E(t) = \frac{1}{L\beta_E} \epsilon^{-\alpha_E t} \sinh \beta_E t \tag{7.42}$$

where $\beta_E = \sqrt{\alpha_E^2 - \frac{1}{LC_E}}$.

The response for this condition is shown in Fig. 7.4B.

If $r_E^2 = 4L/C_E$, then $\sin \omega_E t$ approaches $\omega_E t$ and the solution is

$$A_E(t) = \frac{t}{L} \epsilon^{-\alpha_E t} \quad 7.43$$

The response for this condition is shown in Fig. 7.4C.

The differential equation of a force driving a mass, mechanical rectilinear resistance and compliance is shown in Fig. 7.4 as

$$m\ddot{x} + r_M\dot{x} + \frac{x}{C_M} = f_M \quad 7.44$$

where m = mass, in grams,

r_M = mechanical rectilinear resistance, in mechanical ohms,

C_M = compliance, in centimeters per dyne,

\ddot{x} = acceleration, in centimeters per second per second,

\dot{x} = velocity, in centimeters per second,

x = displacement, in centimeters, and

f_M = driving force, in dynes.

Substituting v for \dot{x} , equation 7.44 may be written

$$m \frac{dv}{dt} + r_M v + \frac{1}{C_M} \int v dt = f_M \quad 7.45$$

The mechanical rectilinear indicial admittance is

$$A_M(t) = \frac{p}{m p^2 + r_M p + \frac{1}{C_M}} \mathbf{1} \quad 7.46$$

Let

$$\alpha_M = \frac{r_M}{m}$$

$$\omega_M = \sqrt{\frac{1}{m C_M} - \alpha_M^2}$$

The mechanical rectilinear indicial admittance is

$$A_M(t) = \frac{1}{m \omega_M} \frac{p \omega_M}{(p + \alpha_M)^2 + \omega_M^2} \mathbf{1} \quad 7.47$$

From the tables of operational formulas the solution is

$$A_M(t) = \frac{1}{m\omega_M} \epsilon^{-\alpha_M t} \sin \omega_M t \quad 7.48$$

The response for $r_M^2 < 4m/C_M$ is shown in Fig. 7.4A. It is a damped sinusoid.

If $r_M^2 > 4m/C_M$, then the solution becomes

$$A_M(t) \frac{1}{m\beta_M} \epsilon^{-\alpha_M t} \sinh \beta_M t \quad 7.49$$

where $\beta_M = \sqrt{\beta_M^2 - \frac{1}{mC_M}}$.

The response of this condition is shown in Fig. 7.4B.

If $r_M^2 = 4m/C_M$ then $\sin \omega_M t$ approaches $\omega_M t$ and the solution is

$$A_M(t) = \frac{t}{m} \epsilon^{-\alpha_M t} \quad 7.50$$

The response for this condition is shown in Fig. 7.4C.

The differential equations of a torque driving a moment of inertia, mechanical rotational resistance and rotational compliance, as shown in Fig. 7.4, is

$$I\ddot{\phi} + r_R\dot{\phi} + \frac{\phi}{C_R} = f_R \quad 7.51$$

where I = moment of inertia, in grams (centimeter),
 r_R = mechanical rotational resistance, in rotational ohms,
 C_R = rotational compliance, in radians per dyne per centimeter,
 $\ddot{\phi}$ = angular acceleration, in radians per second per second,
 $\dot{\phi}$ = angular velocity, in radians per second,
 ϕ = angular displacement, in radians, and
 f_R = driving torque, in dyne centimeters.

Substituting θ for ϕ , equation 7.51 may be written

$$\frac{d\theta}{dt} + r_R\theta + \frac{1}{C_R} \int \theta dt = f_R \quad 7.52$$

The mechanical rotational indicial admittance is

$$A_R(t) = \frac{p}{I p^2 + r_R p + \frac{1}{C_R}} \mathbf{1} \quad 7.53$$

Let

$$\alpha_R = \frac{r_R}{I}$$

$$\omega_R = \sqrt{\frac{1}{I C_R} + \alpha_R^2}$$

The mechanical rotational indicial admittance is

$$A_R(t) = \frac{1}{I \omega_R} \frac{p \omega_R}{(p + \alpha_R)^2 + \omega_R^2} \mathbf{1} \quad 7.54$$

From the tables of operational formulas the solution is

$$A_R(t) = \frac{1}{I \omega_R} \epsilon^{-\alpha_R t} \sin \omega_R t \quad 7.55$$

The response for $r_R^2 < 4I/C_R$ is shown in Fig. 7.4*A*. It is a damped sinusoid.

If $r_R^2 > 4I/C_R$, then the solution becomes

$$A_R(t) = \frac{1}{I \beta_R} \epsilon^{-\alpha_R t} \sinh \beta_R t \quad 7.56$$

where $\beta_R = \sqrt{\alpha_R^2 - \frac{1}{I C_R}}$.

The response for this condition is shown in Fig. 7.4*B*.

If $r_R^2 = 4I/C_R$, then $\sin \omega_R t$ approaches $\omega_R t$ and the solution is

$$A_R(t) = \frac{t}{I} \epsilon^{-\alpha_R t} \quad 7.57$$

The response for this condition is shown in Fig. 7.4*C*.

The differential equation of a sound pressure driving an acoustical resistance and an inductance connected to an acoustical capacitance, as shown in Fig. 7.4, is

$$M\ddot{X} + r_A\dot{X} + \frac{X}{C_A} = p \quad 7.58$$

where M = inductance, in grams per (centimeter)⁴,
 r_A = acoustical resistance, in acoustical ohms,
 C_A = acoustical capacitance, in (centimeter)⁵ per dyne,
 \dot{X} = volume current, in cubic centimeters per second, and
 p = pressure, in dynes per square centimeter.

Substituting U for \dot{X} , equation 7.58 may be written

$$M \frac{dU}{dt} + r_A U + \frac{1}{C_A} \int U dt = p \quad 7.59$$

The acoustical indicial admittance is

$$A_A(t) = \frac{p}{Mp^2 + r_A p + \frac{1}{C_A}} \mathbf{1} \quad 7.60$$

Let

$$\alpha_A = \frac{r_A}{2M}$$

$$\omega_A = \sqrt{\frac{1}{MC_A} - \alpha_A^2}$$

The acoustical indicial admittance is

$$A_A(t) = \frac{1}{M\omega_A} \frac{p\omega_A}{(p + \alpha_A)^2 + \omega_A^2} \mathbf{1} \quad 7.61$$

From the tables of operational formulas, the solution of equation 7.61 is

$$A_A(t) = \frac{1}{M\omega_A} \epsilon^{-\alpha_A t} \sin \omega_A t \quad 7.62$$

The response for $r_A^2 < 4M/C_A$ is shown in Fig. 7.4A. It is a damped sinusoid.

If $r_A^2 > 4M/C_A$, then the solution becomes

$$A_A(t) = \frac{1}{L\beta_A} \epsilon^{-\alpha_A t} \sinh \beta_A t \quad 7.63$$

where $\beta_A = \sqrt{\alpha_A^2 - \frac{1}{MC_A}}$.

The response for this condition is shown in Fig. 7.4B.

If $r_A^2 = 4M/C_A$, then $\sin \omega_A t$ approaches $\omega_A t$ and the solution is

$$A_A(t) = \frac{t}{M} \epsilon^{-\alpha_A t} \quad 7.64$$

The response for this condition is shown in Fig. 7.4C.

7.6. Arbitrary Force

In the preceding sections the response of various combinations of elements to a unit force has been obtained. The value of the unit force

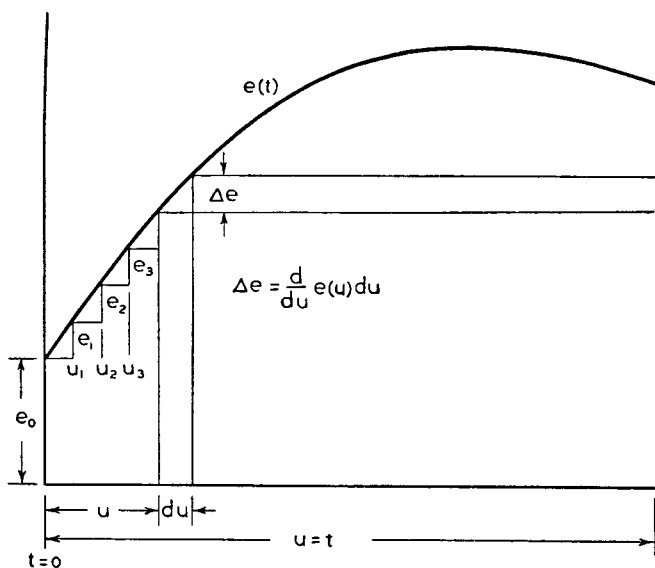

FIG. 7.5. Step function approximation.

solution is that the response to any arbitrary force can be obtained from the unit force solution by a single integration of Duhamel's integral.

It is the purpose of this section to illustrate the proof and use of this integral.

The discussion will be confined to the electrical system. This proof, as in the case of the preceding sections, can be extended to apply to mechanical and acoustical systems. Let the arbitrary electromotive force be represented by the curve of Fig. 7.5. The curve can be assumed to be made up of a series of unit type electromotive forces, as shown in Fig. 7.5. At $t = 0$ an electromotive force e_0 is impressed upon the system. A time u_1 later, an electromotive force e_1 is added, a time u_2 later, an electromotive force e_2 is added, etc., all being of the unit type. The current at a time t is then the sum of the currents due to e_0 at $t = 0$, e_1 at $t = u_1$, etc. The current due to e_0 is $e_0 A_E(t)$, where $A_E(t)$ is the indicial electrical admittance. The current due to the electromotive force Δe , which begins at time u , is obviously $\Delta e A_E(t - u)$, $t - u$ being the time elapsed since the unit electromotive force Δe was turned on. Therefore, the total current at the time $u = t$ is

$$i = e_0 A_E(t) + \sum_{u=0}^{u=t} \Delta e A_E(t - u) \quad 7.65$$

$$e = \frac{d}{du} e(u) du$$

$$i = e_0 A_E(t) + \int_0^t A_E(t - u) \frac{d}{du} e(u) du \quad 7.66$$

The above expression may be transformed into different forms. The integral may be transformed by integrating as follows:

$$\int_0^t U dV = UV \Big|_0^t - \int_0^t V dU \quad 7.67$$

$$U = A(t - u)$$

$$dV = de(u)$$

$$V = e(u)$$

Making the above substitutions, a new expression for the current follows:

$$i = e(t) A_E(0) + \int_0^t e(u) \frac{\partial}{\partial u} A_E(t - u) du \quad 7.68$$

Equation 7.68 is a fundamental formula which shows the mathematical relation between the current and the type of electromotive force and the constants of the system.

The important conclusions regarding Duhamel's integral are as follows: The indicial admittance of an electrical network determines within a single integration the behavior of a network to any type of electromotive force. In other words a knowledge of the indicial admittance is the only information necessary to completely predict the performance of a system including the steady state.

The velocity, angular velocity and volume current in the mechanical rectilinear, mechanical rotational and acoustical systems are analogous to the equation for the current in the electrical system. Therefore Duhamel's integrals in the mechanical rectilinear, mechanical rotational and acoustical systems are as follows:

$$v = f_M(t)A_M(0) + \int_0^t f_M(u) \frac{\partial}{\partial u} A_M(t-u) du \quad 7.69$$

$$\theta = f_R(t)A_R(0) + \int_0^t f_R(u) \frac{\partial}{\partial u} A_R(t-u) du \quad 7.70$$

$$U = p(t)A_A(0) + \int_0^t p(u) \frac{\partial}{\partial u} A_A(t-u) du \quad 7.71$$

The following general conclusion can be stated as follows: The indicial admittance of any vibrating system determines within a single integration the behavior of the system to any type of applied force.

The Heaviside calculus then becomes an important tool in the solution of transient problems in mechanical and acoustical systems. Since a great number of problems in these fields involve impulsive forces the use of analogies makes it possible to use the tremendous storehouse of information on electrical systems for the solution of problems in mechanical and acoustical systems.

As an example illustrating the use of Duhamel's integral consider an electromotive force $E\epsilon^{-\beta t}$ impressed on the electrical circuit of Fig. 7.3 consisting of an electrical resistance and electrical capacitance in series.

The indicial electrical admittance from equation 7.28 is

$$A_E(t) = \frac{1}{r_E} \epsilon^{-\frac{1}{C_{FE}} t} \quad 7.72$$

It follows from equation 7.72 that

$$A_E(t - u) = \frac{1}{r_E} \epsilon^{-\frac{1}{C_{E\tau E}}(t-u)}$$

$$\frac{\partial}{\partial t} A_E(t - u) = -\frac{1}{C_{E\tau E}^2} \epsilon^{-\frac{1}{C_{E\tau E}}(t-u)}$$

$$e(u) = E \epsilon^{-\beta u}$$

$$e(t) = E \epsilon^{-\beta t}$$

$$A_E(0) = \frac{1}{r_E}$$

Substituting the above expression in equation 7.68, the current is given by

$$i = E \frac{\epsilon^{-\beta t}}{r_E} + \int_0^t -E \frac{\epsilon^{-\beta u}}{C_{E\tau E}^2} \epsilon^{-\frac{1}{C_{E\tau E}}(t-u)} du \quad 7.73$$

$$i = \frac{EC_E}{1 - C_{E\tau E}\beta} \left[\frac{\epsilon^{-\frac{1}{C_{E\tau E}}t}}{C_{E\tau E}} - \beta \epsilon^{-\beta t} \right] \quad 7.74$$

Similar analysis and analogous equations may be obtained for a combination of a mechanical rectilinear resistance and a compliance, a mechanical rotational resistance and a rotational compliance, and an acoustical resistance and an acoustical capacitance.

CHAPTER VIII

DRIVING SYSTEMS

8.1. Introduction

An electromechanical or electroacoustic transducer or driving system is a system for converting electrical vibrations into the corresponding mechanical or acoustical vibrations. The most common driving systems in use to-day for converting electrical variations into mechanical vibrations are the electrodynamic, the electromagnetic, the electrostatic, the magnetostrictive and the piezoelectric. It is the purpose of this chapter to consider the electrical and mechanical characteristics of these driving systems.

8.2. Electrodynamic Driving System

A moving coil or dynamic driving system is a driving system in which the mechanical forces are developed by the interaction of currents

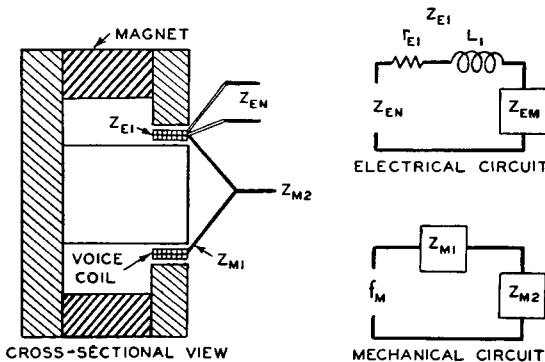

FIG. 8.1. Electrodynamic driving system. In the electrical circuit: z_{EN} , the normal electrical impedance of the voice coil. z_{EM} , the motional electrical impedance of the voice coil. z_{E1} , the damped electrical impedance of the voice coil. $z_{E1} = r_{E1} + j\omega L_1$. L_1 and r_{E1} , the damped inductance and electrical resistance of the voice coil. In the mechanical circuit: f_M , the driving force. z_{M1} , the mechanical rectilinear impedance of the voice coil. z_{M2} , the mechanical rectilinear impedance of the load.

in a conductor and the magnetic field in which it is located. The system is depicted in Fig. 8.1. The force, in dynes, due to the interaction of the current in the voice coil and the polarizing field is

$$f_M = Bli \quad 8.1$$

where B = flux density, in gaussses,
 l = length of the conductor, in centimeters, and
 i = current, in abamperes.

The electromotive force, in abvolts, developed by the motion of the conductor is

$$e = Bl\dot{x} \quad 8.2$$

where \dot{x} = velocity, in centimeters per second.

From equations 8.1 and 8.2

$$\frac{e}{i} = (Bl)^2 \frac{\dot{x}}{f_M} \quad 8.3$$

$$\frac{e}{i} = z_{EM} \quad 8.4$$

where z_{EM} = electrical impedance, in abohms, due to motion, termed motional electrical impedance.

From the mechanical circuit ¹ of Fig. 8.1, the mechanical rectilinear impedance of the vibrating system at the voice coil is

$$z_M = z_{M1} + z_{M2} \quad 8.5$$

¹ In the illustrations in the preceding chapters the elements in the electrical network have been labeled r_E , L and C_E . However, in using analogies in actual practice, the conventional procedure is to label the elements in the analogous electrical network with r_M , m and C_M for a mechanical rectilinear system, with r_R , I and C_R for a mechanical rotational system and with r_A , M and C_A for an acoustical system. This procedure will be followed in this chapter in labeling the elements of the analogous electrical circuit. It is customary to label this network with the caption "analogous electrical network of the mechanical system" (or of the rotational system or of the acoustical system) or with the caption "mechanical network" (or rotational network or acoustical network). The latter convention will be used in this chapter. When there is only one path, circuit will be used instead of network.

where z_M = the total mechanical rectilinear impedance at the conductor, in mechanical ohms,

z_{M1} = the mechanical rectilinear impedance of the voice coil and suspension system, in mechanical ohms, and

z_{M2} = the mechanical rectilinear impedance of the load, in mechanical ohms.

The mechanical rectilinear impedance at the voice coil is

$$z_M = \frac{f_M}{\dot{x}} \quad 8.6$$

The electrical impedance due to motion from equations 8.3, 8.4 and 8.6 is

$$z_{EM} = \frac{(Bl)^2}{z_M} \quad 8.7$$

The motional electrical impedance of a transducer is the vector difference between its normal and blocked electrical impedance.

The normal electrical impedance of a transducer is the electrical impedance measured at the input to the transducer when the output is connected to its normal load.

The blocked electrical impedance of a transducer is the electrical impedance measured at the input when the mechanical rectilinear system is blocked, that is, in the absence of motion.

The normal electrical impedance z_{EN} , in abohms, of the voice coil is

$$z_{EN} = z_{E1} + z_{EM} \quad 8.8$$

where z_{E1} = damped electrical impedance of the voice coil, in abohms, and

z_{EM} = motional impedance of the voice coil, in abohms.

The motional electrical impedance as given by equation 8.8 may be represented as in series with the blocked or damped electrical impedance of the conductor, as depicted by the electrical circuit in Fig. 8.1.

The dynamic driving system is almost universally used for all types of direct radiator and horn loud speakers.

8.3. Electromagnetic Driving Systems

A magnetic driving system is a driving system in which the mechanical forces result from magnetic reactions. There are three general types of

magnetic driving systems, namely, the unpolarized armature type, the polarized reed type and the polarized balanced armature type.

A. Unpolarized Armature Type.—The unpolarized armature driving system consists of an electromagnet operating directly upon an armature. The armature is spaced at a small distance from the pole piece wound with insulated wire carrying the alternating current. Since there is no polarizing flux, the driving force frequency is twice the frequency of the impressed current to the coil.

Consider the system shown in Fig. 8.2. Assume that all the reluctance

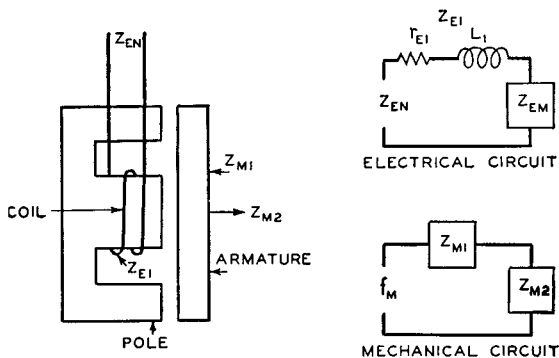

FIG. 8.2. Unpolarized armature electromagnetic driving system. In the electrical circuit: z_{EN} , the normal electrical impedance of the coil. z_{EM} , the motional electrical impedance of the coil. z_{E1} , the damped impedance of the coil. $z_{E1} = r_{E1} + j\omega L_1$. L_1 and r_{E1} , the damped inductance and electrical resistance of the coil. In the mechanical circuit: f_M , the driving force. z_{M1} , the mechanical rectilinear impedance of the armature. z_{M2} , the mechanical rectilinear impedance of the load.

resides in the air gap. The total flux, in maxwells, through the middle pole, in the absence of motion is

$$\phi_T = \frac{2\pi n A i}{a} = \frac{C i}{a} \quad 8.9$$

where n = number of turns,

A = area of the middle pole, in square centimeters, it is assumed that the combined area of the two outside poles is equal to the area of the middle pole

a = spacing between the armature and pole, in centimeters,

i = current, in abamperes, and

$C = 2\pi n A$.

Assume that the armature is displaced from its normal position a distance Δx centimeters towards the pole; the total flux is

$$\phi_T + \Delta\phi_T = \frac{Ci}{a - \Delta x} \quad 8.10$$

Now let the armature be displaced a distance Δx centimeters away from the pole; the total flux is

$$\phi_T - \Delta\phi_T = \frac{Ci}{a + \Delta x} \quad 8.11$$

The difference in flux for these two conditions is

$$2\Delta\phi_T = \frac{2Ci\Delta x}{a^2 - (\Delta x)^2} \quad 8.12$$

The change in flux with respect to time is

$$\frac{\Delta\phi_T}{\Delta t} = \frac{Ci}{a^2 - (\Delta x)^2} \frac{\Delta x}{\Delta t} \quad 8.13$$

The voltage, in abvolts, generated due to motion is

$$e = n \frac{d\phi}{dt} \quad 8.14$$

If Δx is small compared to a , then from equations 8.13 and 8.14

$$e = \frac{nCi}{a^2} \dot{x} \quad 8.15$$

The force on the armature, in dynes, is

$$f_M = \frac{(2\phi_T)^2}{16\pi A} = \frac{C^2 i^2}{4\pi A a^2} \quad 8.16$$

where i = current in the coil, in abamperes,

$C = 2\pi nA$,

A = area of the center pole, in square centimeters,

n = number of turns, and

a = normal spacing, in centimeters.

If the current in the coil is sinusoidal, then the expression for the current can be written

$$i = i_{\max} \sin \omega t \quad 8.17$$

where i_{\max} = amplitude of the current in abamperes,

$$\omega = 2\pi f$$

f = frequency in cycles per second, and

t = time, in seconds.

Substituting equation 8.17 for the current in 8.16, the force on the armature is

$$\begin{aligned} f_M &= \frac{C^2}{4\pi Aa^2} i_{\max}^2 \sin^2 \omega t \\ &= \frac{C^2}{4\pi Aa^2} i_{\max}^2 \left(\frac{1}{2} - \frac{1}{2} \cos 2\omega t \right) \end{aligned} \quad 8.18$$

Equation 8.18 shows that there is a steady force and an alternating driving force of twice the frequency of the impressed current.

From the mechanical circuit of Fig. 8.2, the mechanical rectilinear impedance of the vibrating system is

$$z_M = z_{M1} + z_{M2} \quad 8.19$$

where z_M = total mechanical rectilinear impedance at the armature, in mechanical ohms,

z_{M1} = mechanical rectilinear impedance of the armature, in mechanical ohms, and

z_{M2} = mechanical rectilinear impedance of the load, in mechanical ohms.

The mechanical rectilinear impedance at the armature is

$$z_M = \frac{f_M}{\dot{x}} \quad 8.20$$

From equations 8.15 and 8.16

$$\frac{e}{i} = \frac{nC^3 i^2 \dot{x}}{4\pi Aa^4 f_M} \quad 8.21$$

From equations 8.19, 8.20 and 8.21

$$z_{EM} = \frac{2\pi^2 n^4 A^2 i^2}{a^4 z_M} \quad 8.22$$

where z_{EM} = motional electrical impedance, in abohms,

n = number of turns,

A = area of center pole, in square centimeters,

i = current, in abamperes,

a = spacing, in centimeters, and

z_M = mechanical rectilinear impedance of the load including the armature, in mechanical ohms.

The normal electrical impedance z_{EN} , in abohms, of the coil is

$$z_{EN} = z_{E1} + z_{EM} \quad 8.23$$

where z_{E1} = damped electrical impedance of the coil, in abohms, and

z_{EM} = motional electrical impedance of the coil, in abohms.

The motional electrical impedance as given by equation 8.23 may be represented as in series with the blocked or damped electrical impedance of the coil as depicted by the electrical circuit in Fig. 8.2.

The frequency of vibration of the armature is twice the frequency of the impressed electrical current. Therefore, this system cannot be used for the reproduction of sound. It is, however, a simple driving system for converting electrical variations into mechanical vibrations of double frequency. The unpolarized driving system is used for low frequency supersonic generators, saws, filing machines, vibrators and clippers.

B. Polarized Reed Armature Type.—A reed armature driving system consists of an electromagnet operating directly upon an armature of steel as in Fig. 8.3. The steel armature is spaced at a small distance from a pole piece wound with insulated wire carrying the alternating current and supplied with steady flux from the poles of a permanent magnet.

The flux, in maxwells, due to the permanent magnet is given by

$$\phi_1 = \frac{M}{R_1} \quad 8.24$$

where M = magnetomotive force of the magnet, in gilberts, and

R_1 = reluctance of the magnetic circuit, in oersteds.

The flux, in maxwells, due to the sinusoidal current $i_{\max} \sin \omega t$ in the coils is given by

$$\phi_2 = \frac{4\pi N i_{\max} \sin \omega t}{R_2} \quad 8.25$$

where N = number of turns in the coil,

i = current in the coil, in abamperes,

R_2 = reluctance of the alternating magnetic circuit, in oersteds,

$\omega = 2\pi f$,

f = frequency, and

t = time.

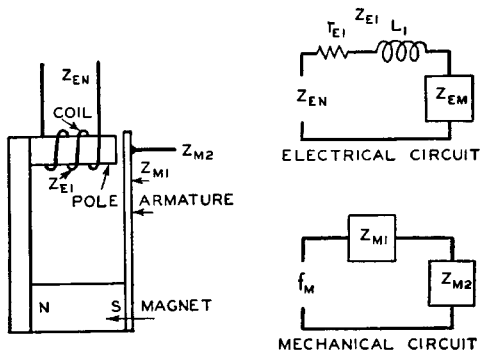

FIG. 8.3. Polarized reed armature electromagnetic driving system. In the electrical circuit: z_{EN} , the normal electrical impedance of the coil. z_{EM} , the motional electrical impedance of the coil. z_{E1} , the damped impedance of the coil. $z_{E1} = r_{E1} + j\omega L_1$. L_1 and r_{E1} , the damped inductance and electrical resistance of the coil. In the mechanical circuit: f_M , the driving force. z_{M1} , the mechanical rectilinear impedance of the armature system. z_{M2} , the mechanical rectilinear impedance of the load.

The force, in dynes, on the armature is

$$f_M = \frac{(\phi_1 + \phi_2)^2}{8\pi A} = \frac{M^2}{8\pi R_1^2 A} + \frac{MN i_{\max} \sin \omega t}{R_1 R_2 A} + \frac{\pi N^2 i_{\max}^2}{R_2^2 A} - \frac{\pi N^2 i_{\max}^2 \cos 2\omega t}{R_2^2 A} \quad 8.26$$

where A = effective area of the pole in square centimeters.

The first and third terms of the right hand side of equation 8.26 represent a steady force, the second term represents a force of the same fre-

quency as the alternating current and the last term represents a force of twice the frequency of the alternating current. Referring to equation 8.26 it will be seen that the driving force is proportional to the steady flux ϕ_1 . Also ϕ_1 must be large compared to ϕ_2 , in order to reduce second harmonic distortion. For these reasons the polarizing flux should be made as large as possible.

The motional electrical impedance of this system will now be considered. If all the reluctance is assumed to reside in the air gap, the flux, in maxwells, through the armature is

$$\phi_1 = \frac{MA}{a} \quad 8.27$$

where M = magnetomotive force, in gilberts, due to the steady field,
 a = spacing between the armature and pole, in centimeters, and
 A = area of the pole, in square centimeters.

Let the armature be deflected a distance Δx towards the pole; the flux will now be

$$\phi_1 + \Delta\phi_1 = \frac{MA}{a - \Delta x} \quad 8.28$$

Now let the armature be pulled away from the normal position a distance of Δx ; the flux will be

$$\phi_1 - \Delta\phi_1 = \frac{MA}{a + \Delta x} \quad 8.29$$

The difference in flux through the armature for these two conditions is

$$2\Delta\phi_1 = \frac{MA}{a - \Delta x} - \frac{MA}{a + \Delta x} = \frac{2MA\Delta x}{a^2 - (\Delta x)^2} \doteq \frac{2MA\Delta x}{a^2} \quad 8.30$$

This change in flux with respect to the time is

$$\frac{d\phi_1}{dt} = \frac{MA}{a^2} \frac{dx}{dt} \quad 8.31$$

The electromotive force, in abvolts, generated in the coil due to this deflection of the armature is

$$e = N \frac{d\phi_1}{dt} = \frac{NMA}{a^2} \dot{x} \quad 8.32$$

Leaving out the steady force and the force of twice the frequency, equation 8.26 becomes

$$f_M = \frac{MNi}{R_1R_2A} \quad 8.33$$

From the mechanical circuit of Fig. 8.3, the mechanical rectilinear impedance of the vibrating system is

$$z_M = z_{M1} + z_{M2} \quad 8.34$$

where z_M = total mechanical rectilinear impedance at the armature directly above the pole piece, in mechanical ohms,
 z_{M1} = mechanical rectilinear impedance of the armature, in mechanical ohms, and
 z_{M2} = mechanical rectilinear impedance of the load in mechanical ohms.

The mechanical rectilinear impedances z_M , z_{M1} , and z_{M2} are referred to a point on the armature directly over the pole piece.

The mechanical rectilinear impedance of the armature directly above the pole piece is

$$z_M = \frac{f_M}{\dot{x}} \quad 8.35$$

Combining equations 8.32 and 8.33,

$$\frac{e}{i} = \frac{\dot{x}}{f_M} \frac{M^2N^2}{R_1R_2a^2} \quad 8.36$$

From equations 8.34, 8.35 and 8.36

$$z_{EM} = \frac{M^2N^2}{R_1R_2a^2z_M} \quad 8.37$$

where z_{EM} = motional impedance, in abohms,

z_M = total mechanical impedance with reference to a point on the armature directly over the pole piece.

From equations 8.24 and 8.37, assuming $R_1 = R_2$

$$z_{EM} = \frac{\phi_1^2N^2}{a^2z_M} \quad 8.38$$

Equation 8.38 is similar to equation 8.7 for the electrodynamic system. The normal electrical impedance z_{EN} , in abohms, of the coil is

$$z_{EN} = z_{E1} + z_{EM} \quad 8.39$$

where z_{E1} = damped electrical impedance of the coil, in abohms, and z_{EM} = motional electrical impedance of the coil, in abohms.

The motional electrical impedance as given by equation 8.38 may be represented as in series with the blocked or damped electrical impedance of the coil as depicted by the electrical circuit in Fig. 8.3.

This driving system is not generally used in loud speakers. The most common example of this driving system is the bipolar telephone receiver where the diaphragm is the armature.

C. Polarized Balanced Armature Type.—There are innumerable possibilities in the design of a magnetic driving system. The preceding

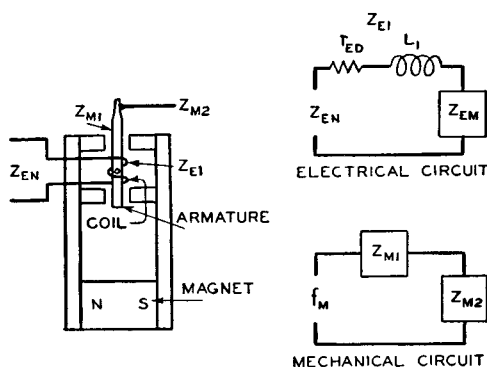

FIG. 8.4. Polarized balanced armature electromagnetic driving system. In the electrical circuit: z_{EN} , the normal electrical impedance of the coil. z_{EM} , the motional electrical impedance of the coil. z_{E1} , the damped electrical impedance of the coil. $z_{E1} = r_{E1} + j\omega L_1$. L_1 and r_{E1} , the damped inductance and electrical resistance of the coil. In the mechanical circuit: f_M , the driving force. z_{M1} , the mechanical rectilinear impedance of the armature. z_{M2} , the mechanical rectilinear impedance of the load. z_{M1} and z_{M2} are referred to a point on the armature directly over a pole piece.

section considered the simplest magnetic driving system in which both the steady flux and the alternating flux flow through the armature. It is the purpose of this section to consider the balanced armature type of driving system in which only the alternating flux flows through the armature.

A typical balanced armature driving system is shown in Fig. 8.4. The steady field is usually supplied by a permanent magnet. The armature is located so that it is in the equilibrium with the steady forces. The alternating current winding is wound around the armature. The steady force, in dynes, at the poles (Fig. 8.4) due to the magnetic field is

$$f_M = \frac{\phi_1^2}{8\pi A} \quad 8.40$$

where ϕ_1 = total flux, in maxwells, at each pole due to the permanent magnet, and
 A = effective area, in square centimeters, of the pole piece.

The flux, in maxwells, at the poles due to a current in the coil is

$$\phi_2 = \frac{4\pi Ni}{R_2} \quad 8.41$$

where N = number of turns in the coil,
 i = current in the coil, in amperes, and
 R_2 = reluctance of the magnetic circuit, in oersteds, which the coil energizes.

The sum of the forces, in dynes, at the four poles acting upon the armature due to a current in the coil is

$$f_M = \frac{2(\phi_1 + \phi_2)^2}{8\pi A} - \frac{2(\phi_1 - \phi_2)^2}{8\pi A} = \frac{\phi_1\phi_2}{\pi A} \quad 8.42$$

or

$$f_M = \frac{4\phi_1 Ni}{R_2 A} \quad 8.43$$

In the case of the simple reed driving system a second harmonic term appeared in the force when a sinusoidal current was passed through the coil. It is interesting to note that in the case of the balanced armature the second harmonic term cancels out due to the push pull arrangement.

The motional impedance of this system will now be considered. Let the armature be deflected clockwise a distance of Δx from the poles. The

flux, in maxwells, through the armature to the right and upward, assuming that the entire reluctance exists in the air gap, is

$$\phi_1 + \Delta\phi_1 = \frac{MA}{2(a - \Delta x)} \quad 8.44$$

where M = magnetomotive force, in gilberts, of the steady field,
 a = spacing between the armature and pole, in centimeters, and
 A = effective area of a pole piece, in square centimeters.

The flux through the armature to the left and downward is

$$\phi_1 - \Delta\phi_1 = \frac{MA}{2(a + \Delta x)} \quad 8.45$$

The flux through the armature is the difference between equations 8.44 and 8.45.

$$\Delta\phi_1 = \frac{MA\Delta x}{a^2 - (\Delta x)^2} \doteq \frac{MA\Delta x}{a^2} \quad 8.46$$

The change in flux with respect to the time is

$$\frac{d\phi}{dt} = \frac{M}{a^2} \frac{dx}{dt} = \frac{MA}{a^2} \dot{x} \quad 8.47$$

The electromotive force, in abvolts, generated in the coil is

$$e = N \frac{d\phi}{dt} = \frac{NMA}{a^2} \dot{x} \quad 8.48$$

From the mechanical circuit of Fig. 8.4, the mechanical rectilinear impedance of the vibrating system is

$$z_M = z_{M1} + z_{M2} \quad 8.49$$

where z_M = total mechanical rectilinear impedance, in mechanical ohms,
 z_{M1} = mechanical rectilinear impedance of the armature, in mechanical ohms, and
 z_{M2} = mechanical rectilinear impedance of the load, in mechanical ohms.

The mechanical rectilinear impedances z_M , z_{M1} , and z_{M2} are referred to a point on the armature directly above a pole piece.

The mechanical rectilinear impedance at the armature directly over a pole piece is

$$z_M = \frac{f_M}{\dot{x}} \quad 8.50$$

Combining equations 8.43 and 8.50,

$$\frac{e}{i} = \frac{4N^2\phi_1 M}{a^2 R_2} \frac{\dot{x}}{f_M} \quad 8.51$$

From equations 8.49, 8.50 and 8.51

$$z_{EM} = \frac{4N^2\phi_1 M}{a^2 R_2 z_M} \quad 8.52$$

where z_{EM} = motional electrical impedance, in abohms, and
 z_M = total mechanical rectilinear impedance including the armature with reference to a point on the armature directly over one of the pole pieces.

If the entire reluctance is assumed to reside in the air gap, equation 8.52 may be written

$$z_{EM} = \frac{4N^2\phi_1^2}{a^2 z_M} \quad 8.53$$

Equation 8.53 is essentially the same as equation 8.38 for the reed armature type and is similar to equation 8.7 for the electrodynamic system. The normal electrical impedance z_{EN} , in abohms, of the coil is

$$z_{EN} = z_{E1} + z_{EM} \quad 8.54$$

where z_{E1} = damped electrical impedance of the coil, in abohms, and
 z_{EM} = motional electrical impedance of the coil, in abohms.

The motional electrical impedance as given by equation 8.53 may be represented as in series with the blocked or damped electrical impedance of the coil as depicted by the electrical circuit in the Fig. 8.4.

When the armature is displaced by the current, means must be provided for returning the armature to the equilibrium position. Due to

the large magnetic forces, the stiffness of the centering system must be relatively large.

This driving system is used for loud speakers, galvanometers, for motion picture film recording and for facsimile printers.

In actual practice it appears very difficult to reduce the stiffness sufficiently so that the resonance of the system will occur below 100 cycles. Therefore, when this driving system is used for a loud speaker the response will fall off quite rapidly below the resonance frequency.

8.4. Electrostatic Driving System

An electrostatic driving system is a driving system in which the mechanical forces result from electrostatic reactions. Consider the system of Fig. 8.5 consisting of a vibrating surface moving normal to

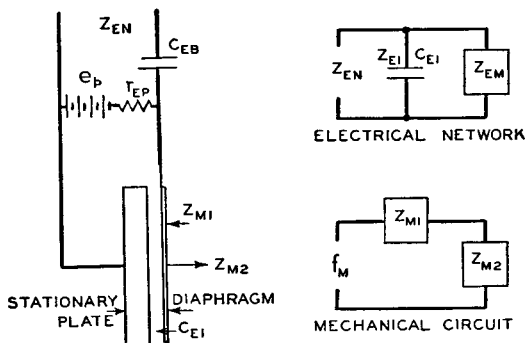

FIG. 8.5. Electrostatic driving system. In the electrical network: z_{EN} , the normal electrical impedance of the condenser. z_{EM} , the motional electrical impedance of the condenser. z_{E1} , the damped electrical impedance of the condenser. $z_{E1} = 1/j\omega C_{E1}$. C_{E1} , the damped electrical capacitance of the condenser. In the mechanical circuit: f_M , the driving force. z_{M1} , the mechanical rectilinear impedance of the movable plate. z_{M2} , the mechanical rectilinear impedance of the load.

its plane and separated from a fixed conductor. The force, in dynes, between the plates is

$$f_M = \frac{e^2 A}{8\pi a^2} \quad 8.55$$

where e = electromotive force between plates, in statvolts,
 a = normal distance between the plates, in centimeters, and
 A = area of the plate, in square centimeters.

Assume that the polarizing voltage is e_0 and that the alternating voltage is $e = e_{\max} \sin \omega t$. The force, in dynes, between the plates is

$$f_M = \frac{(e_0 + e_{\max} \sin \omega t)^2 A}{8\pi a^2} \quad 8.56$$

$$f_M = \frac{e_0^2 + 2e_0 e_{\max} \sin \omega t + \frac{1}{2}e_{\max}^2 - \frac{1}{2}e_{\max}^2 \cos 2\omega t}{8\pi a^2} A \quad 8.57$$

The first and third terms in the numerator of equation 8.57 represent steady forces. The fourth term is an alternating force of twice the frequency of the impressed voltage. The second term is an alternating force of the frequency of the impressed voltage. If the polarizing electromotive e_0 is large compared to the alternating electromotive force $e_{\max} \sin \omega t$, the fourth term will be negligible. The useful force, in dynes, then is the second term which causes the moving surface to vibrate with a velocity which corresponds to the impressed electromotive force.

$$f_M = \frac{e_0 e_{\max} \sin \omega t}{4\pi a^2} A = \frac{e_0 e}{4\pi a^2} A \quad 8.58$$

The motional impedance of this system will now be considered.

The charge, in statcoulombs, on the condenser is

$$q = C_E e_0 \quad 8.59$$

where e_0 = potential difference between the plates, in statvolts, and C_E = capacity per unit area, in statfarads.

The current, in statamperes, generated due to motion is

$$i = \frac{dq}{dt} \quad 8.60$$

From equations 8.59 and 8.60 the generated current is

$$i = e_0 \frac{dC_E}{dx} \frac{dx}{dt} \quad 8.61$$

The capacitance of the condenser, in statfarads, is

$$C_{E1} = \frac{A}{4\pi a} \quad 8.62$$

Let the movable plate be deflected a distance Δx away from the fixed plate. The capacitance is

$$C_{E1} - \Delta C_{E1} = \frac{A}{4\pi(a + \Delta x)} \quad 8.63$$

Now let the movable plate be deflected a distance Δx towards the fixed plate. The capacitance is

$$C_{E1} + \Delta C_{E1} = \frac{A}{4\pi(a - \Delta x)} \quad 8.64$$

The difference between the two conditions is

$$\Delta C_{E1} = \frac{A\Delta x}{4\pi[a^2 - (\Delta x)^2]} \doteq \frac{A\Delta x}{4\pi a^2} \quad 8.65$$

The change in capacitance with respect to x is

$$\frac{dC_{E1}}{dx} = \frac{1}{4\pi a^2} \quad 8.66$$

Substituting equation 8.66 in 8.61, the generated current, in statamperes, is

$$i = \frac{e_0 A}{4\pi a^2} \dot{x} \quad 8.67$$

From the mechanical circuit of Fig. 8.5, the mechanical rectilinear impedance of the vibrating system is

$$z_M = z_{M1} + z_{M2} \quad 8.68$$

where z_M = total mechanical rectilinear impedance of the vibrating system, in mechanical ohms,

z_{M1} = mechanical rectilinear impedance of the vibrating plate, in mechanical ohms, and

z_{M2} = mechanical rectilinear impedance of the load, in mechanical ohms.

The mechanical rectilinear impedance at the plate is

$$z_M = \frac{f_M}{\dot{x}} \quad 8.69$$

From equations 8.58 and 8.67

$$\frac{e}{i} = \frac{16\pi^2 a^4 f_M}{e_0^2 A^2 \dot{x}} \quad 8.70$$

From equations 8.68, 8.69 and 8.70

$$z_{EM} = \frac{16\pi^2 a^4}{e_0^2 A^2} z_M \quad 8.71$$

where z_{EM} = motional electrical impedance, in statohms, and
 z_M = total mechanical rectilinear impedance presented to the
vibrating surface including the vibrating surface.

The normal electrical impedance z_{EN} , in statohms, of the condenser is

$$z_{EN} = \frac{z_{E1} z_{EM}}{z_{E1} + z_{EM}} \quad 8.72$$

where z_{E1} = damped electrical impedance of the condenser, in statohms,
and
 z_{EM} = motional electrical impedance of the condenser, in statohms.

The motional electrical impedance as given by equation 8.72 may be represented as in parallel with the blocked or damped electrical impedance of the condenser as depicted by the electrical network in Fig. 8.5.

The condenser driving system has been employed as a loud speaker in which case the moving electrode radiates directly into the air. Means must be provided to keep the electrodes separated without, at the same time, adding a large stiffness. In a bilateral or push pull arrangement the movable electrode is placed between two stationary plates and the large steady forces are balanced out.

8.5. Magnetostriction Driving System

A magnetostriction driving system is a driving system in which the mechanical forces result from the deformation of a ferromagnetic mate-

rial having magnetostriction properties. The term "Joule effect" is applied to the phenomena in which a change in linear dimensions occurs when a magnetic field is applied along a specified direction. The term "Villari effect" is applied to the phenomena in which a change in magnetic induction occurs when a mechanical stress is applied along a specified direction.

Consider the system shown in Fig. 8.6. Assume that the rod is clamped so that no motion is possible and that a current is applied to

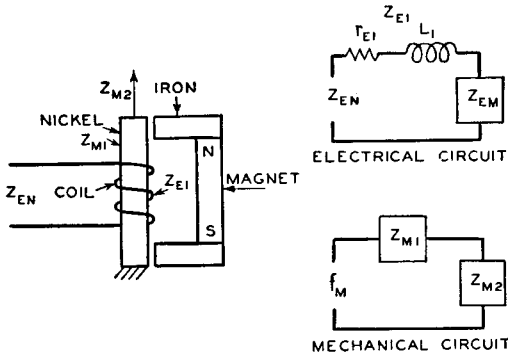

FIG. 8.6. Magnetostriction driving system. In the electrical circuit: z_{EN} , the normal electrical impedance of the coil. z_{EM} , the motional electrical impedance of the coil. z_{E1} , the damped electrical impedance of the coil. $z_{E1} = r_{E1} + j\omega L_1$. L_1 and r_{E1} , the damped inductance and electrical resistance of the coil. In the mechanical circuit: f_M , the driving force. z_{M1} , the mechanical rectilinear impedance of the rod. z_{M2} , the mechanical rectilinear impedance of the load.

the winding; then the mechanical stress, in dynes, due to the Joule effect, is

$$f_M = AKB \sin \omega t + AB_P K \quad 8.73$$

where K = constant representing the dynamical Joule magnetostriction effect,

A = cross-sectional area of the rod, in square centimeters,

B_P = polarizing flux, in gaussses,

B = amplitude of the alternating flux, in gaussses,

$\omega = 2\pi f$,

f = frequency, in cycles per second, and

t = time, in seconds.

The relation between flux and the current is

$$B = \frac{4\pi Ni}{RA} \quad 8.74$$

where N = number of turns,

i = current in the coil, in abamperes,

R = reluctance of the magnetic circuit, and

A = area of the rod, in square centimeters.

Combining equations 8.73 and 8.74 and eliminating the steady force,

$$f_M = \frac{4\pi NiK}{R} \sin \omega t \quad 8.75$$

where K = constant representing the dynamical Joule magnetostriction effect,

R = reluctance of the magnetic circuit,

N = number of turns in the coil,

i = current, in abamperes,

$\omega = 2\pi f$,

f = frequency, in cycles per second, and

t = time, in seconds.

If the rod is allowed to vibrate, this stress may be considered to be the driving force.

The electromotive force, in abvolts, induced in the winding, due to the Villari effect, is

$$e = NA \frac{dB}{dt} \quad 8.76$$

where N = number of turns,

A = cross-sectional area of the nickel rod, in square centimeters, and

B = magnetic induction, in gauss.

The magnetic induction is

$$B = \frac{4\pi K}{AR} x \quad 8.77$$

where x = total extension of deformation, in centimeters, and

K = constant representing the dynamical Villari magnetostriction effect.

The induced voltage, in abvolts, is

$$e = \frac{4\pi NK}{R} \dot{x} \quad 8.78$$

From equation 8.75

$$i = \frac{f_M R}{4\pi NK}$$

$$\frac{e}{i} = \frac{16\pi^2 N^2 K^2}{R^2} \frac{\dot{x}}{f_M} \quad 8.79$$

In the above consideration it has been assumed that the stress and driving force are uniform over the length of the rod. Under these conditions the rod is a compliance given by

$$C_{M1} = \frac{l}{EA} \quad 8.80$$

where A = cross-sectional area of the rod, in square centimeters,
 l = length of the rod, in centimeters, and
 E = Young's modulus.

The mechanical rectilinear impedance of the rod is

$$z_{M1} = \frac{1}{j\omega C_{M1}} \quad 8.81$$

For the conditions under consideration the mechanical rectilinear impedance of the vibrating system, from the mechanical circuit of Fig. 8.6, is

$$z_M = z_{M1} + z_{M2} \quad 8.82$$

where z_M = total mechanical rectilinear impedance, in mechanical ohms,
 z_{M1} = mechanical rectilinear impedance of the rod, in mechanical ohms, and
 z_{M2} = mechanical rectilinear impedance of the load, in mechanical ohms.

The mechanical rectilinear impedances z_M , z_{M1} and z_{M2} are referred to one end of the rod with the other end rigidly fixed. The dimensions of the rod are assumed to be small compared to the wavelength.

The mechanical rectilinear impedance at the end of the rod is

$$z_M = \frac{f_M}{\dot{x}} \quad 8.83$$

From equations 8.79, 8.82 and 8.83

$$z_{EM} = \frac{16\pi^2 N^2 K^2}{R^2 z_M} \quad 8.84$$

where z_{EM} = motional electrical impedance, in abohms, and
 z_M = total mechanical rectilinear impedance load upon the rod,
 including the effective mechanical rectilinear impedance
 of the rod, in mechanical ohms.

The normal impedance of the coil is

$$z_{EN} = z_{E1} + z_{EM} \quad 8.85$$

where z_{E1} = damped impedance of the voice coil, in abohms, and
 z_{EM} = motional impedance, in abohms—equation 8.84.

The damped impedance of the coil of most magnetostriction systems comprises a resistance in series with an inductance (Fig. 8.6). The damped impedance and the motional impedance are effectively in series, as shown by equation 8.85 and depicted by the electrical circuit in Fig. 8.6.

In the above considerations the length of the rod is assumed to be a small fraction of the wavelength. In general, magnetostriction driving systems² are operated at resonance. The three most common systems are as follows: a rod fixed on one end and loaded on the other, a rod free on one end and loaded on the other and a free rod. The lumped constant representations of the three systems depicted by the mechanical networks in Fig. 8.7 are valid near the resonant frequency of the rod.

The mass m_1 in Fig. 8.7 is given by

$$m_1 = \frac{\rho l A}{2} \quad 8.86$$

² Mason, "Electromechanical Transducers and Wave Filters," D. Van Nostrand Co., New York, 1942.

where ρ = density of the rod material, in grams per cubic centimeter,
 l = length of the rod, in centimeters, and
 A = cross section of the rod, in square centimeters.

The compliance C_{M1} , in Fig. 8.7, is given by

$$C_{M1} = \frac{8l}{\pi^2 EA} \quad 8.87$$

where A = cross-sectional area of the rod, in square centimeters,
 l = length of the rod, in centimeters, and
 E = Young's modulus.

The compliance given by equation 8.87 is $8/\pi^2$ times the static compliance given by equation 8.80.

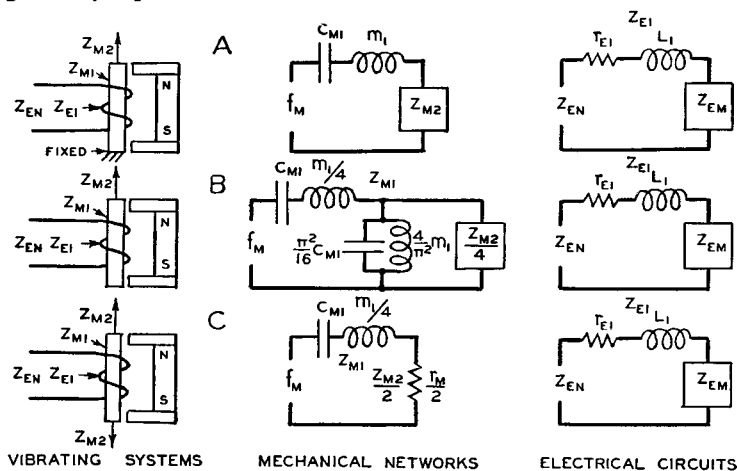

FIG. 8.7. Magnetostriction driving systems. A. Rod fixed on one end and loaded on the other. B. Rod free on one end and loaded on the other. C. Free rod, that is, a light load on both ends. In the electrical circuits: z_{EN} , the normal electrical impedance of the coil. z_{EM} , the motional electrical impedance of the coil. z_{E1} , the damped electrical impedance of the coil. $z_{E1} = r_{E1} + j\omega L_1$. L_1 and r_{E1} , the damped inductance and electrical resistance of the coil. In the mechanical networks: f_M , the driving force. z_{M2} , the mechanical rectilinear impedance of the mechanical load. z_{M1} , the mechanical rectilinear impedance of the rod. m_1 and C_{M1} the effective mass and compliance of the rod.

The load on the end of the rod is the mechanical rectilinear impedance z_{M2} . In the case of a free rod, Fig. 8.7C, the only load is the dissipation

due to resistance, that is, air load and support resistance. This load is designated as the mechanical rectilinear resistance r_M in Fig. 8.7C.

The vibrating systems A and B given in Fig. 8.7 are usually employed to produce sound waves in liquids or gases. The vibrating system of Fig. 8.7C is usually employed as an element in a filter or as a frequency standard. For the latter use it is important that the load be very small.

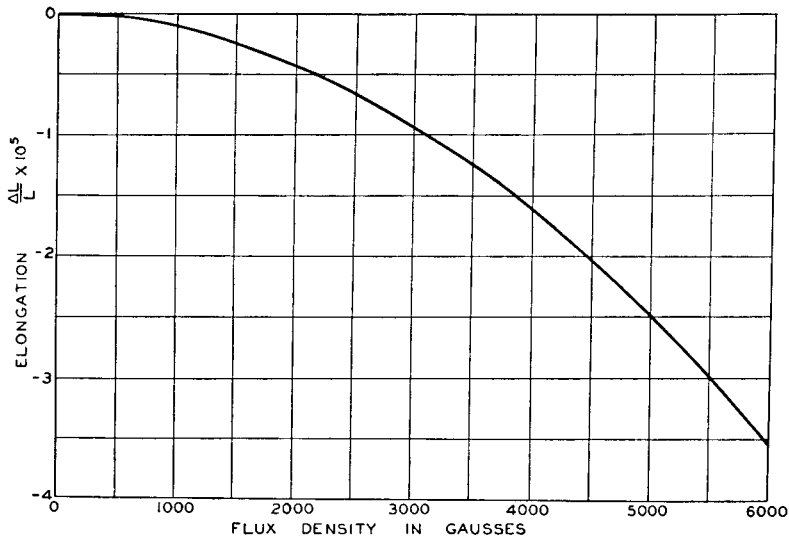

FIG. 8.8. Magnetostriction in nickel.

The mechanical rectilinear impedance z_M at f_M can be obtained from the mechanical networks of Fig. 8.7. The motional electrical impedance z_{EM} can be obtained from equation 8.84. The normal electrical impedance can then be determined from the electrical circuits of Fig. 8.7.

The magnetostrictive constant may be determined from the deformation-flux density characteristic. The elongation per unit length as a function of the flux density for nickel is shown in Fig. 8.8.

The deformation per unit length, due to a force, is

$$x = \frac{f_M}{EA} \quad 8.88$$

where f_M = total force, in dynes,

A = area, in square centimeters, and

E = Young's modulus.

The magnetostrictive force is

$$f_M = KAB \quad 8.89$$

where K = magnetostriction constant,
 B = flux density, and
 A = area, in square centimeters.

From equations 8.88 and 8.89 the deformation per unit length is

$$x = \frac{KB}{E} \quad 8.90$$

The magnetostrictive constant K can be determined from the above equation, the data of Fig. 8.8 and Young's modulus.

8.6. Piezoelectric Driving System

A piezoelectric driving system is a driving system in which the mechanical forces result from the deformation of a crystal having converse

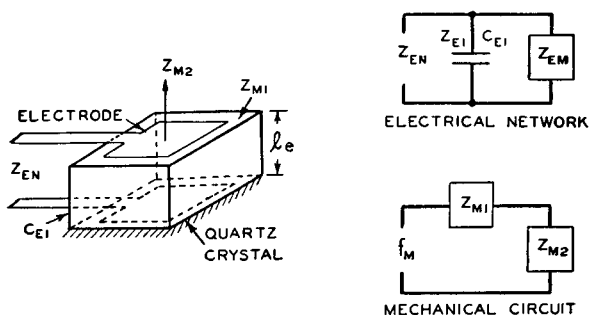

FIG. 8.9. Piezoelectric driving system. In the electrical network: z_{EN} , the normal electrical impedance of the crystal. z_{EM} , the motional electrical impedance of the crystal. z_{E1} , the damped electrical impedance of the crystal. $z_{E1} = 1/j\omega C_{E1}$. C_{E1} , the damped electrical capacitance of the crystal. In the mechanical circuit: f_M , the driving force. z_{M1} , the mechanical rectilinear impedance of the crystal. z_{M2} , the mechanical rectilinear impedance of the load.

piezoelectric properties. Among the crystals that exhibit piezoelectric phenomena are quartz, tourmaline, and Rochelle salt.

The consideration will be that of an X cut quartz crystal (Fig. 8.9).

The charge, in statcoulombs, due to the application of a force, is

$$q = Kf_M \quad 8.91$$

where K = constant of the crystal, 6.4×10^{-8} for quartz, and
 f_M = force, in dynes.

The displacement, in centimeters, due to an applied force, is

$$x = \frac{f_M l_e}{EA} \quad 8.92$$

where f_M = force, in dynes,
 l_e = length of the crystal, in centimeters,
 E = Young's modulus, and
 A = cross-sectional area, in square centimeters.

From equations 8.91 and 8.92

$$x = \frac{l_e q}{KEA} \quad 8.93$$

Differentiating equation 8.93,

$$\dot{x} = \frac{l_e \dot{q}}{KEA} \quad 8.94$$

The deflection, in centimeters, due to the application of a voltage, is

$$x = Ke \quad 8.95$$

where K = constant of the crystal, 6.4×10^{-8} for quartz, and
 e = applied voltage, in statvolts.

From equations 8.92 and 8.95

$$f_M = \frac{KEAe}{l_e} \quad 8.96$$

From equations 8.94 and 8.96

$$\frac{e}{i} = \frac{l_e^2 f_M}{K^2 E^2 A^2 \dot{x}} \quad 8.97$$

In the above consideration it has been assumed that the stress and driving force are uniform over the length l_e of the crystal. Under these conditions the crystal is a compliance given by

$$C_{M1} = \frac{l_e}{EA} \quad 8.98$$

where, A = cross-sectional area of the crystal, in square centimeters,
 l = length of the crystal, in centimeters, and
 E = Young's modulus.

The mechanical rectilinear impedance of the crystal is

$$z_{M1} = \frac{1}{j\omega C_{M1}} \quad 8.99$$

For the conditions under consideration the mechanical rectilinear impedance of the vibrating system, from the mechanical circuit of Fig. 8.9, is

$$z_M = z_{M1} + z_{M2} \quad 8.100$$

where z_M = total mechanical rectilinear impedance, in mechanical ohms,
 z_{M1} = mechanical rectilinear impedance of the crystal, in mechanical ohms, and
 z_{M2} = mechanical rectilinear impedance of the load, in mechanical ohms.

The mechanical rectilinear impedances z_M , z_{M1} and z_{M2} are referred to one end of the crystal with the other end rigidly fixed. The dimensions of the crystal are assumed to be small compared to the wavelength.

The mechanical rectilinear impedance at the end of the crystal is

$$z_M = \frac{f_M}{\dot{x}} \quad 8.101$$

From equations 8.97, 8.100 and 8.101

$$z_{EM} = \frac{l_e^2}{K^2 E^2 A^2} z_M \quad 8.102$$

where z_{EM} = motional electrical impedance, in statohms, and
 z_M = total mechanical rectilinear impedance including the crystal.

The normal electrical impedance of the crystal system is

$$z_{EN} = \frac{z_{EM}}{1 + j\omega C_{E1} z_{EM}} \quad 8.103$$

where z_{EM} = motional impedance, equation 8.102, and

C_{E1} = capacitance of the crystal in the absence of motion.

The damped impedance and the motional impedance are effectively in parallel as shown by equation 8.103 and depicted by the electrical circuit in Fig. 8.9.

In the above considerations the length of the crystal is assumed to be a small fraction of the wavelength. In general, piezoelectric driving systems are operated at resonance. The three most common systems³ are as follows: a crystal fixed on one end and loaded on the other, a crystal free on one end and loaded on the other and a free crystal. The lumped constant representations of the three systems depicted by the mechanical networks in Fig. 8.10 are valid near the resonant frequency of the crystal.

The mass m_1 , in Fig. 8.10, is given by

$$m_1 = \frac{\rho l_e A}{2} \quad 8.104$$

where ρ = density of the crystal, in grams per cubic centimeter,

l_e = length of the crystal, in centimeters, and

A = cross-sectional area of the crystal, in square centimeters.

The compliance C_{M1} , in Fig. 8.10, is given by

$$C_{M1} = \frac{8l_e}{\pi^2 EA} \quad 8.105$$

where A = cross-sectional area of the crystal, in square centimeters,

l_e = length of the crystal, in centimeters, and

E = Young's modulus.

The compliance given by equation 8.105 is $8/\pi^2$ times the static compliance given by equation 8.98.

³ Mason, "Electromechanical Transducers and Wave Filters," D. Van Nostrand Co., New York, 1942.

The load on the end of the crystal is the mechanical rectilinear impedance z_{M2} . In the case of a free crystal, Fig. 8.10C, the only load is the dissipation due to resistance, that is, air load and support resistance. This load is designated as the mechanical rectilinear resistance r_M in Fig. 8.10C.

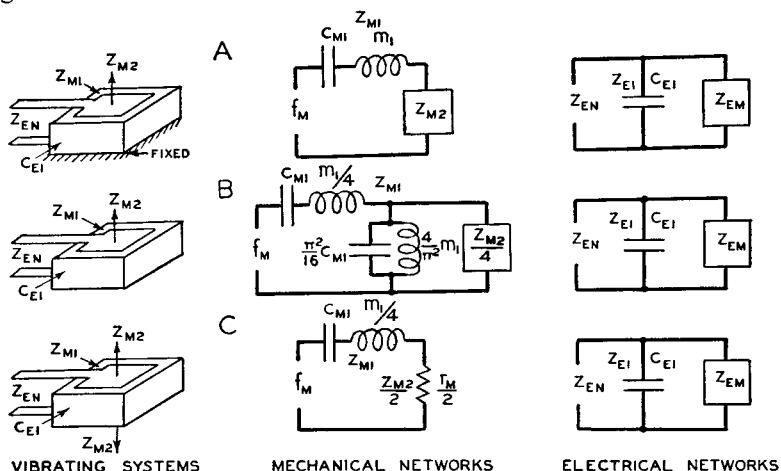

FIG. 8.10. Piezoelectric driving systems. A. Crystal fixed on one end and loaded on the other. B. Crystal free on one end and loaded on the other. C. Free crystal, that is, a light load on both ends. In the electrical networks: z_{EN} , the normal electrical impedance of the crystal. z_{EM} , the motional electrical impedance of the crystal. z_{E1} , the damped electrical impedance of the crystal. $z_{E1} = 1/j\omega C_{E1}$. C_{E1} , the damped electrical capacitance of the crystal. In the mechanical networks: f_M , the driving force. z_{M2} , the mechanical rectilinear impedance of the mechanical load. z_{M1} , the mechanical rectilinear impedance of the crystal. m_1 and C_{M1} , the effective mass and compliance of the crystal.

The vibrating systems *A* and *B* in Fig. 8.10 are usually employed to produce sound waves in liquids or gases. The vibrating system of Fig. 8.10C is usually employed as an element in a filter or as a frequency standard. For the latter use it is important that the load be very small.

The mechanical rectilinear impedance z_M at f_M can be obtained from the mechanical networks of Fig. 8.10. The motional electrical impedance z_{EM} can be obtained from equation 8.102. The normal electrical impedance can then be determined from the electrical networks of Fig. 8.10.

CHAPTER IX

GENERATING SYSTEMS

9.1. Introduction

A mechanical electrical generating system is a system for converting mechanical or acoustical vibrations into the corresponding electrical variations. The most common generating systems in use to-day for converting mechanical vibrations into the corresponding electrical variations are the electrodynamic, the electromagnetic, the electrostatic, the piezoelectric and the magnetostriction. It is the purpose of this chapter to describe the electrical and mechanical characteristics of these generating systems.

9.2. Electrodynamic Generating System

A moving conductor or a moving coil generating system is a generating system in which the electromotive force is developed by motion of a conductor through a magnetic field.

The voltage, in abvolts, due to the motion of the conductor in the magnetic field, Fig. 9.1, is

$$e = Bl\dot{x} \quad 9.1$$

where B = flux density, in gaussses,

l = length of the conductor, in centimeters, and

\dot{x} = velocity of the conductor, in centimeters per second.

The velocity of the conductor is governed by the mechanical driving force, the mechanical rectilinear impedance of the mechanical system, and the mechanical rectilinear impedance due to the electrical system. The vibrating system is shown in Fig. 9.1. In the mechanical circuit ¹ z_M represents the mechanical rectilinear impedance of the mechanical portion of the vibrating system actuated by f_M including the mechanical rectilinear impedance of the coil at the voice coil. f_M represents the

¹See footnote 1, page 125.

mechanomotive force at the voice coil. The mechanical rectilinear impedance due to the electrical system from equation 8.7 of the chapter on Driving Systems, is

$$z_{ME} = \frac{(Bl)^2}{z_E} \quad 9.2$$

where B = flux density, in gausses,

l = length of the conductor, in centimeters,

$$z_E = z_{E1} + z_{E2},$$

z_{E1} = electrical impedance of the voice coil, in abohms, and

z_{E2} = electrical impedance of the external load, in abohms.

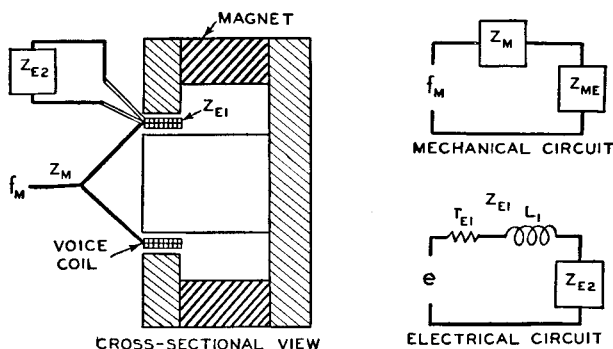

FIG. 9.1. Electrodynamic generating system. In the mechanical circuit: f_M , the external driving force. z_M , the total mechanical rectilinear impedance of the mechanical portion of the vibrating system actuated by f_M . z_{ME} , the mechanical rectilinear impedance due to the electrical circuit. In the electrical circuit: e , the internal electromotive force generated in the voice coil. $z_{E1} = r_{E1} + j\omega L_1$. L_1 and r_{E1} , the damped inductance and electrical resistance of the voice coil. z_{E2} , the electrical impedance of the external load.

The velocity of the voice coil is

$$\dot{x} = \frac{f_M}{z_M + z_{ME}} \quad 9.3$$

From equations 9.1 and 9.3 the generated electromotive force, in abvolts, is

$$e = Bl\dot{x} = \frac{Blf_M}{z_M + z_{ME}} \quad 9.4$$

The generated electromotive force is effectively in series with the electrical impedance z_{E1} of the voice coil and the electrical impedance z_{E2} of the external load, as depicted by the electrical circuit in Fig. 9.1.

9.3. Electromagnetic Generating Systems

A magnetic generating system is a generating system in which the electromotive force is developed by the change in magnetic flux through a stationary coil. There are two general types of magnetic generating systems; namely, the reed armature type and the balanced armature type.

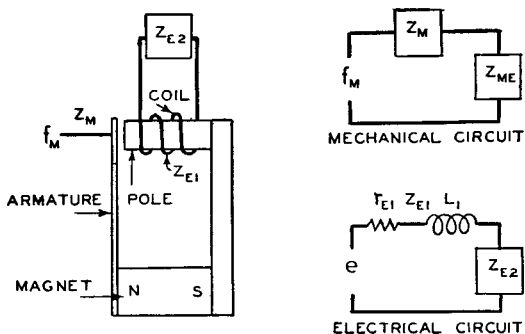

FIG. 9.2. Reed armature electromagnetic generating system. In the mechanical circuit: f_M , the external driving force. z_M , the total mechanical rectilinear impedance of the mechanical portion of the vibrating system actuated by f_M . z_{ME} , the mechanical rectilinear impedance due to the electrical circuit: In the electrical circuit: e , the internal electromotive force generated in the coil. $z_{E1} = r_{E1} + j\omega L_1$. L_1 and r_{E1} , the damped inductance and electrical resistance of the coil. z_{E2} , the electrical impedance of the external load.

A. *Reed Armature Generating System.*—The reed armature generating system, shown in Fig. 9.2, consists of a coil around a polarized magnetic field in which the reluctance is varied by an armature of steel. The variation of reluctance causes a corresponding change in magnetic flux through the coil and thereby leads to the induction of an electromotive force.

The electromotive force, in abvolts, generated in the coil due to motion of the armature from equation 8.32 of the chapter on Driving Systems, is

$$e = \frac{NMA}{a^2} \dot{x} \quad 9.5$$

where N = number of turns in the coil,
 M = magnetomotive force, in gilberts, due to the steady field,
 A = area of the pole, in square centimeters,
 a = spacing between the armature and pole, in centimeters, and
 \dot{x} = velocity of the armature, in centimeters per second.

The velocity of the armature is governed by the mechanical driving force, the mechanical rectilinear impedance of the mechanical system, and the mechanical rectilinear impedance due to the electrical system. The vibrating system is shown in Fig. 9.2. In the mechanical circuit z_M represents the mechanical rectilinear impedance of the mechanical portion of the vibrating system actuated by f_M including the mechanical rectilinear impedance of the armature. f_M represents the mechanomotive force at the armature. The mechanical rectilinear impedance due to the electrical system from equation 8.38 of the chapter on Driving Systems is

$$z_{ME} = \frac{\phi_1^2 N^2}{a^2 z_E} \quad 9.6$$

where ϕ_1 = total flux, in maxwells, through the armature,
 N = number of turns on the coil,
 a = spacing between the armature and pole, in centimeters, and
 $z_E = z_{E1} + z_{E2}$,
 z_{E1} = electrical impedance of the coil, in abohms, and
 z_{E2} = electrical impedance of the external load, in abohms.

The velocity of the armature, in centimeters per second, is

$$\dot{x} = \frac{f_M}{z_M + z_{ME}} \quad 9.7$$

From equations 9.5 and 9.7

$$e = \frac{NMA}{a^2} \dot{x} = \frac{NMAf_M}{a^2(z_M + z_{ME})} \quad 9.8$$

The generated electromotive force is effectively in series with the electrical impedance z_{E1} of the coil and the electrical impedance z_{E2} of the external load as depicted by the electrical circuit in Fig. 9.2.

B. *Balanced Armature Generating System.*—In the simple generating system of the preceding section both the steady magnetic flux and the change in flux, due to the deflection of the armature, flows through the armature. Consider a balanced armature type of generating system in which only the alternating flux flows longitudinally through the armature as shown in Fig. 9.3.

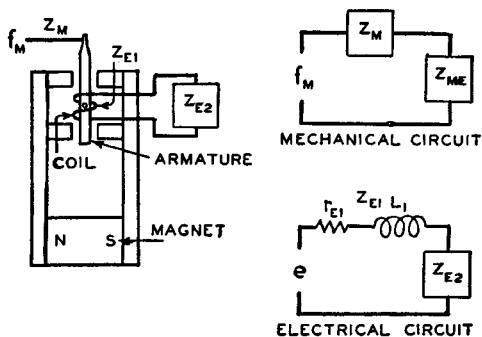

FIG. 9.3. Balanced armature electromagnetic generating system. In the mechanical circuit: z_M , the total mechanical rectilinear impedance of the mechanical portion of the vibrating system actuated by f_M . z_{ME} , the mechanical rectilinear impedance due to the electrical circuit. In the electrical circuit: e , the internal electromotive force generated in the coil. z_{E1} , the damped electrical impedance of the coil. $z_{E1} = r_{E1} + j\omega L_1$. L_1 and r_{E1} , the damped inductance and electrical resistance of the coil. z_{E2} , the electrical impedance of the external load.

The electromotive force, in abvolts, generated in the coil due to motion of the armature from equation 8.48 of the chapter on Driving Systems is

$$e = \frac{NMA}{a^2} \dot{x} \quad 9.9$$

where N = number of turns in the coil,

M = magnetomotive force, in gilberts, of the steady field,

A = area of a pole piece, in square centimeters,

a = spacing between the armature and pole, in centimeters, and

\dot{x} = velocity of the armature, in centimeters per second.

The velocity of the armature is governed by the mechanical driving force, the mechanical rectilinear impedance of the mechanical system, and the mechanical rectilinear impedance due to the electrical system.

The vibrating system is shown in Fig. 9.3. In the mechanical circuit z_M represents the mechanical rectilinear impedance of the mechanical portion of the vibrating system including the mechanical rectilinear impedance of the armature. f_M represents the mechanomotive force on the armature. The mechanical rectilinear impedance due to the electrical system from equation 8.52 of the chapter on Driving Systems is

$$z_{ME} = \frac{4N^2\phi M}{a^2 R_2 z_E} \quad 9.10$$

where N = number of turns in the coil,

ϕ = total flux in the air gap at one of the poles, in maxwells,

M = magnetomotive force, in gilberts, of the magnet,

a = spacing between armature and pole, in centimeters,

R_2 = reluctance, in oersteds, of the alternating magnetic circuit,

$z_E = z_{E1} + z_{E2}$,

z_{E1} = electrical impedance of the coil, in abohms, and

z_{E2} = electrical impedance of the external load, in abohms.

The velocity of the armature, in centimeters per second, is

$$\dot{x} = \frac{f_M}{z_M + z_{ME}} \quad 9.11$$

From equations 9.9 and 9.11

$$e = \frac{NMA}{a^2} \dot{x} = \frac{NMAf_M}{a^2(z_M + z_{ME})} \quad 9.12$$

The generated electromotive force is effectively in series with the electrical impedance z_{E1} of the coil and the electrical impedance z_{E2} of the external load, as depicted by the electrical circuit in Fig. 9.3.

9.4. Electrostatic Generating System

A condenser or electrostatic generating system is a generating system in which the electromotive force is developed by the relative motion between two differently electrostatically charged plates.

The current, in statamperes, generated by the motion of the movable plate of the condenser from equation 8.67 of the chapter on Driving Systems is

$$i_1 = \frac{e_0 A \dot{x}}{4\pi a^2} \quad 9.13$$

where e = polarizing voltage, in statvolts,
 A = area of the plate, in square centimeters,
 a = spacing between the plates, in centimeters, and
 \dot{x} = velocity of the movable plate, in centimeters per second.

The current, in statamperes, due to the electromotive force e across the electrical impedances z_{E1} and z_{E2} of Fig. 9.4 is

$$i_2 = -\frac{e}{z_E} \quad 9.14$$

where e = electromotive force, in statvolts,

$$z_E = \frac{z_{E1}z_{E2}}{z_{E1} + z_{E2}}$$

$$z_{E1} = \frac{1}{j\omega C_{E1}}$$

C_{E1} = electrical capacitance of the condenser, in statfarads, and
 z_{E2} = electrical impedance of the external load, in statohms.

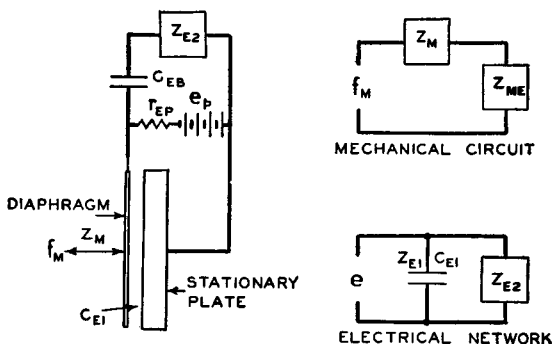

FIG. 9.4. Electrostatic generating system. In the mechanical circuit: z_M , the total mechanical rectilinear impedance of the mechanical portion of the vibrating system actuated by f_M . z_{ME} , the mechanical rectilinear impedance due to the electrical circuit. In the electrical network: e , the electromotive force generated across the condenser. z_{E1} , the damped electrical impedance of the condenser. $z_{E1} = 1/j\omega C_{E1}$. C_{E1} , damped electrical capacitance of the condenser. z_{E2} , the electrical impedance of the external load.

Since there is no external current applied on the electrical side of the system the sum of the currents i_1 and i_2 is zero. From equations 9.13

and 9.14 the generated electromotive force, e , in statvolts, across the electrical impedances z_{E1} and z_{E2} is

$$e = \frac{e_0 A \dot{x}}{4\pi a^2} z_E \quad 9.15$$

The velocity of the movable plate is governed by the mechanical driving force, the mechanical rectilinear impedance of the mechanical system and the mechanical rectilinear impedance due to the electrical system. The vibrating system is shown in Fig. 9.4. In the mechanical circuit z_M represents the mechanical rectilinear impedance of the mechanical portion of the vibrating system actuated by f_M including the mechanical impedance of the movable plate. f_M represents the mechano-motive force at the movable plate. The mechanical rectilinear impedance due to the electrical system from equation 8.71 of the chapter on Driving Systems is

$$z_{ME} = \frac{e_0^2 A^2}{16\pi^2 a^4} z_E \quad 9.16$$

where e_0 = polarizing voltage, in statvolts,
 a = spacing between plates, in centimeters,
 A = area of the plates, in square centimeters,

$$z_E = \frac{z_{E1} z_{E2}}{z_{E1} + z_{E2}}$$

$$z_{E1} = \frac{1}{j\omega C_{E1}}$$

C_{E1} = capacity of the generator, in statfarads,

z_{E2} = electrical impedance of the external load, in statohms.

The velocity of the movable plate, in centimeters per second, is

$$\dot{x} = \frac{f_M}{z_M + z_{ME}} \quad 9.17$$

From equations 9.15 and 9.17 the electromotive force e across z_{E1} and z_{E2} in parallel, depicted by the electrical network of Fig. 9.4, is

$$e = \frac{e A z_E f_M}{4\pi a^2 (z_M + z_{ME})} \quad 9.18$$

The electromotive force e_1 in series with z_{E1} and z_{E2} which will produce the electromotive force e across z_{E2} is of interest in the design of generating systems.

Equation 9.15 may be written

$$e = \frac{e_0 A \dot{x}}{4\pi a^2} \left(\frac{z_{E1} z_{E2}}{z_{E1} + z_{E2}} \right) \quad 9.19$$

The electrical capacitance of the condenser C_{E1} from equation 8.62 of the chapter on Driving Systems is

$$C_{E1} = \frac{A}{4\pi a} \quad 9.20$$

The electrical impedance z_{E1} is

$$z_{E1} = \frac{1}{j\omega C_{E1}} = \frac{4\pi a}{j\omega A} \quad 9.21$$

Substituting equation 9.21 in 9.19,

$$e = \frac{e_0 \dot{x}}{aj\omega} \left(\frac{z_{E2}}{z_{E1} + z_{E2}} \right) \quad 9.22$$

The amplitude in terms of the velocity is

$$x = \frac{\dot{x}}{j\omega} \quad 9.23$$

Substituting equation 9.23 in 9.22,

$$e = \frac{e_0 x}{a} \left(\frac{z_{E2}}{z_{E1} + z_{E2}} \right) \quad 9.24$$

The electromotive force e in terms of e_1 and the impedances z_{E1} and z_{E2} is

$$e = \frac{e_1 z_{E2}}{z_{E1} + z_{E2}} \quad 9.25$$

Comparing equations 9.24 and 9.25,

$$e_1 = \frac{e_0 x}{a} \quad 9.26$$

The electrostatic generating system may be considered to consist of a generator having an internal or open circuit electromotive force e_1 as given by equation 9.26 and an internal impedance z_{E1} . Equation 9.26 shows that this electromotive force is independent of the frequency if the amplitude is independent of the frequency. However, the voltage e across the load may vary with frequency depending upon the nature of load z_{E2} .

9.5. Magnetostriction Generating System

A magnetostriction generating system is a generating system in which the electromotive force is developed in a stationary coil by a change in

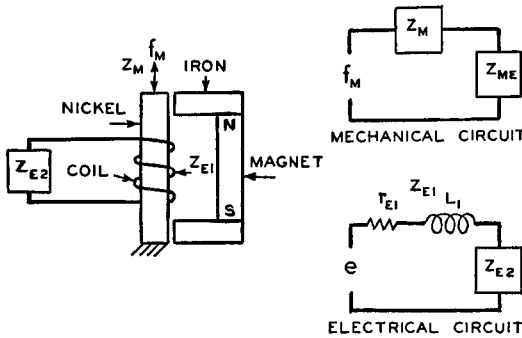

FIG. 9.5. Magnetostriction generating system. In the mechanical circuit: z_M , the total mechanical rectilinear impedance of the mechanical portion of the vibrating system actuated by f_M . z_{ME} , the mechanical rectilinear impedance due to the electrical circuit. In the electrical circuit: e , the internal electromotive force generated in the coil. z_{E1} , the damped electrical impedance of the coil. $z_{E1} = r_{E1} + j\omega L_1$. L_1 and r_{E1} , the damped inductance and electrical resistance of the coil. z_{E2} , the electrical impedance of the external load.

magnetic flux due to the deformation of a ferromagnetic material having magnetostriction properties. The magnetostriction generator, shown in Fig. 9.5, consists of a coil surrounding a magnetic circuit which includes a ferromagnetic material having magnetostriction properties. The voltage, in abvolts, developed in the coil due to deformation of the rod, from equation 8.78 of the chapter on Driving Systems, is

$$e = \frac{4\pi NK}{R} \dot{x} \quad 9.27$$

where N = number of turns in the coil,
 R = reluctance of the magnetic circuit,
 K = constant representing the dynamical Villari magnetostriction effect, and
 \dot{x} = velocity at the point of application of the driving force to the rod, in centimeters per second.

The velocity of the rod is governed by the mechanical driving force, the mechanical impedance of the mechanical system and the mechanical impedance due to the electrical system. The vibrating system is shown in Fig. 9.5. In the mechanical circuit z_M represents the mechanical rectilinear impedance of the mechanical portion of the vibrating system actuated by f_M including the mechanical rectilinear impedance of the magnetostriction rod. f_M represents the mechanomotive force on the rod. It is assumed that the force f_M is the same at all points along the length of the rod and that the phase of the amplitude is constant along the rod. The mechanical rectilinear impedance due to the electrical system from equation 8.79 or 8.84 of the chapter on Driving Systems is

$$z_{ME} = \frac{16\pi^2 N^2 K^2}{z_E R^2} \quad 9.28$$

where N = number of turns in the coil,
 K = magnetostriction constant,
 R = reluctance of the magnetic circuit, and
 $z_E = z_{E1} + z_{E2}$,
 z_{E1} = electrical impedance of the coil, in abohms, and
 z_{E2} = electrical impedance of the external circuit, in abohms.

The dimensions of the rod are assumed to be a small fraction of a wavelength. Under these conditions the rod is a compliance given by

$$C_{M1} = \frac{l}{EA} \quad 9.29$$

where A = cross-sectional area of the rod, in square centimeters,
 l = length of the rod, in centimeters, and
 E = Young's modulus.

The mechanical rectilinear impedance of the rod is

$$z_{M1} = \frac{1}{j\omega C_{M1}} \quad 9.30$$

For the conditions under consideration the mechanical rectilinear impedance of the vibrating system is

$$z_M = z_{M1} + z_{M2} \quad 9.31$$

where z_M = total mechanical rectilinear impedance, in mechanical ohms,
 z_{M1} = mechanical rectilinear impedance of the rod, in mechanical ohms, and
 z_{M2} = mechanical rectilinear impedance of the load, in mechanical ohms.

The velocity of the rod, in centimeters per second, at the driving point is

$$\dot{x} = \frac{f_M}{z_M + z_{ME}} \quad 9.32$$

From equations 9.27 and 9.32 the generated electromotive force, in abvolts, is

$$e = \frac{4\pi N K f_M}{(z_M + z_{ME})R} \quad 9.33$$

The generated electromotive force is effectively in series with the electrical impedance z_{E1} of the coil and the electrical impedance z_{E2} of the external load as depicted by the electrical circuit in Fig. 9.5.

In the above considerations the length of the rod is assumed to be a small fraction of the wavelength. In general, magnetostriction generating systems are operated at resonance. The two most common systems are as follows: a rod fixed on one end and driven on the other and a rod free on one end and driven on the other. The lumped constant representations of the two systems shown in Fig. 9.6, are valid near the resonant frequency of the rod. The mass m_1 and compliance C_{M1} , in Fig. 9.6, are given by equations 8.86 and 8.87 in the chapter on Driving Systems. The load on the end of the rod is the mechanical rectilinear impedance z_{M2} . The mechanical rectilinear impedance z_{ME} due to the electrical circuit is given by equation 9.28. From the above constants and the driving force f_M the velocity in the mechanical circuit can be

determined. The open circuit electromotive force e of the electrical circuit of Fig. 9.6 can be obtained from equation 9.27 and the velocity.

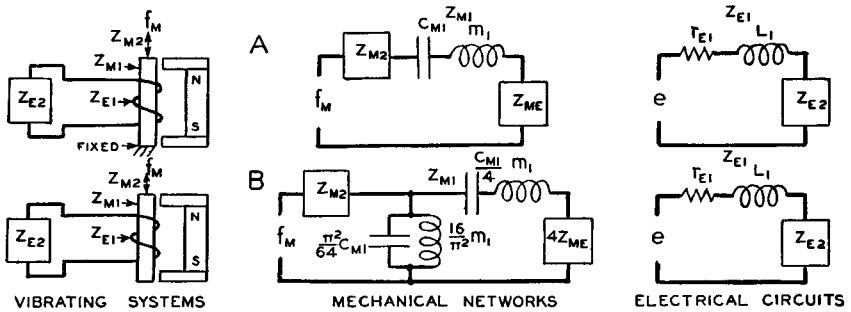

FIG. 9.6. Magnetostriction generating systems. A. Rod fixed on one end and driven on the other. B. Rod free on one end and driven on the other. In the mechanical networks: f_M , the driving force. z_{ME} , the mechanical rectilinear impedance due to the electrical circuit. z_{M2} , the mechanical rectilinear impedance of the external mechanical load. z_{M1} , the mechanical rectilinear impedance of the rod. m_1 and C_{M1} , the effective mass and compliance of the rod. In the electrical circuits: e , the internal electromotive force generated in the coil. z_{E1} , the damped electrical impedance of the coil. $z_{E2} = r_{E1} + j\omega L_1$. L_1 and r_{E1} , the damped inductance and electrical resistance of the coil, z_{E2} , the electrical impedance of the external electrical load.

9.6. Piezoelectric Generating System

A piezoelectric generating system is a generating system in which the electromotive force is developed by the deformation of a crystal having converse piezoelectric properties. The crystal generating system, shown in Fig. 9.7, consists of a suitably ground crystal having converse piezoelectric properties fitted with appropriate electrodes.

The current, in statamperes, generated by the motion of the crystal from equation 8.94 of the chapter on Driving Systems is

$$i_1 = \frac{KEA}{l_c} \dot{x} \tag{9.34}$$

- where K = constant of the crystal, 6.4×10^{-8} for quartz,
- E = Young's modulus,
- l_c = length of the crystal, in centimeters,
- A = cross-sectional area of the crystal, in square centimeters,
- length of the crystal, in centimeters, and
- \dot{x} = velocity of the crystal, in centimeters per second.

The current, in statamperes, due to the electromotive force e across the electrical impedances z_{E1} and z_{E2} is

$$i_2 = -\frac{e}{z_E} \quad 9.35$$

where e = electromotive force, in statvolts,

$$z_E = \frac{z_{E1}z_{E2}}{z_{E1} + z_{E2}}$$

$$z_{E1} = \frac{1}{j\omega C_{E1}}$$

C_{E1} = electrical capacitance of the crystal, in statfarads, and

z_{E2} = electrical impedance of the external load, in statohms.

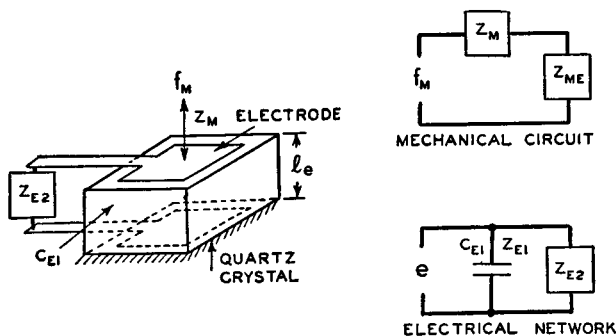

FIG. 9.7. Piezoelectric generating system. In the electrical circuit: z_M , the total mechanical rectilinear impedance of the mechanical portion of the vibrating system actuated by f_M . z_{ME} , the mechanical rectilinear impedance due to the electrical network. In the electrical circuit: e , the electromotive force generated across the crystal. z_{E1} , the damped electrical impedance of the crystal. $z_{E1} = 1/j\omega C_{E1}$. C_{E1} , the damped electrical capacitance of the crystal. z_{E2} , the electrical impedance of the external load.

Since there is no external current applied to the electrodes of the crystal the sum of the currents i_1 and i_2 is zero. From equations 9.34 and 9.35 the generated electromotive force e , in statvolts, across the electrical impedance z_{E1} and z_{E2} is

$$e = \frac{KEA\dot{x}}{l_e} z_E \quad 9.36$$

The velocity at the end of the crystal is governed by the mechanical driving force, the mechanical rectilinear impedance of the mechanical

system and the mechanical rectilinear impedance due to the electrical system. The vibrating system is shown in Fig. 9.7. In the mechanical circuit z_M represents the mechanical rectilinear impedance of the mechanical portion of the vibrating system actuated by f_M including the mechanical rectilinear impedance of the crystal. f_M represents the mechanomotive force at the end of the crystal. It is assumed that the force f_M is the same at all points along the length of the crystal and that the phase of the amplitude is constant along the crystal. The mechanical impedance due to the electrical system from equation 8.97 or 8.102 of the chapter on Driving Systems is

$$z_{ME} = \frac{K^2 E^2 A^2}{l_e^2} z_E \quad 9.37$$

where K = constant of the crystal 6.4×10^{-8} for quartz,

E = Young's modulus,

l_e = length of the crystal, in centimeters,

A = area of the electrode, in centimeters, length of the crystal, in centimeters, and

$$z_E = \frac{z_{E1} z_{E2}}{z_{E1} + z_{E2}} \quad 9.38$$

$$z_{E1} = \frac{1}{j\omega C_{E1}} \quad 9.39$$

C_{E1} = capacitance of the generator, in statfarads,

z_{E2} = electrical impedance of the external load, in statohms.

The dimensions of the crystal are assumed to be a small fraction of a wavelength. Under these conditions the crystal is a compliance given by

$$C_{M1} = \frac{l_e}{EA} \quad 9.40$$

where A = cross-sectional area of the crystal, in square centimeters,

l_e = length of the crystal, in centimeters, and

E = Young's modulus.

The mechanical rectilinear impedance of the crystal is

$$z_{M1} = \frac{1}{j\omega C_{M1}} \quad 9.41$$

For the conditions under consideration the mechanical rectilinear impedance of the vibrating system is

$$z_M = z_{M1} + z_{M2} \quad 9.42$$

where z_M = total mechanical rectilinear impedance, in mechanical ohms,
 z_{M1} = mechanical rectilinear impedance of the crystal, in mechanical ohms, and
 z_{M2} = mechanical rectilinear impedance of the load, in mechanical ohms.

The velocity at the end of crystal, in centimeters per second, is

$$\dot{x} = \frac{f_M}{z_M + z_{ME}} \quad 9.43$$

From equations 9.36 and 9.43 the electromotive force across z_{E1} and z_{E2} in parallel, depicted by the electrical network of Fig. 9.7, is

$$e = \frac{KEAz_E f_M}{l_e(z_M + z_{ME})} \quad 9.44$$

The electromotive force e_1 in series with z_{E1} and z_{E2} which will produce the electromotive force e across z_{E2} is of interest in the design of generating systems.

Equation 9.36 may be written

$$e = \frac{KEA\dot{x}}{l_e} \left(\frac{z_{E1}z_{E2}}{z_{E1} + z_{E2}} \right) \quad 9.45$$

The electrical capacitance of the crystal is

$$C_{E1} = \frac{AD}{4\pi l_e} \quad 9.46$$

where D = dielectric constant of the crystal.

The electrical impedance z_{E1} is

$$z_{E1} = \frac{1}{j\omega C_{E1}} = \frac{4\pi l_e}{j\omega AD} \quad 9.47$$

Substituting 9.47 in 9.45,

$$e = \frac{4\pi KE\dot{x}}{j\omega D} \left(\frac{z_{E2}}{z_{E1} + z_{E2}} \right) \quad 9.48$$

The amplitude in terms of the velocity is

$$x = \frac{\dot{x}}{j\omega} \quad 9.49$$

Substituting 9.49 in 9.48,

$$e = \frac{4\pi KE\dot{x}}{D} \left(\frac{z_{E2}}{z_{E1} + z_{E2}} \right) \quad 9.50$$

The electromotive force e in terms of e_1 is

$$e = \frac{e_1 z_{E2}}{z_{E1} + z_{E2}} \quad 9.51$$

Comparing equations 9.50 and 9.51,

$$e_1 = \frac{4\pi KE\dot{x}}{D} \quad 9.52$$

The piezoelectric generating system may be considered to consist of a generator having an internal or open circuit electromotive force e_1 as given by equation 9.52 and an internal impedance z_{E1} . Equation 9.52 shows that this electromotive force is independent of the frequency if the amplitude is independent of the frequency. However, the voltage e across the load may vary with frequency depending upon the nature of the load z_{E2} .

In the above considerations the length of the crystal is assumed to be a small fraction of the wavelength. In general piezoelectric generating systems are operated at resonance. The two most common systems are as follows: a crystal fixed on one end and driven on the other and a crystal free on one end and driven on the other. The lumped constant representations of the two systems shown in Fig. 9.8 are valid near the resonant frequency of the crystal. The mass m_1 and compliance C_{M1} , in Fig. 9.8, are given by equations 8.104 and 8.105 in the chapter on Driving Systems. The load on the end of the crystal is the mechanical rectilinear impedance z_{M2} . The mechanical rectilinear impedance z_{ME}

due to the electrical circuit is given by equation 9.37. From the above constants and the driving force f_M the velocity in the mechanical circuit can be determined. The electromotive e across the crystal of the

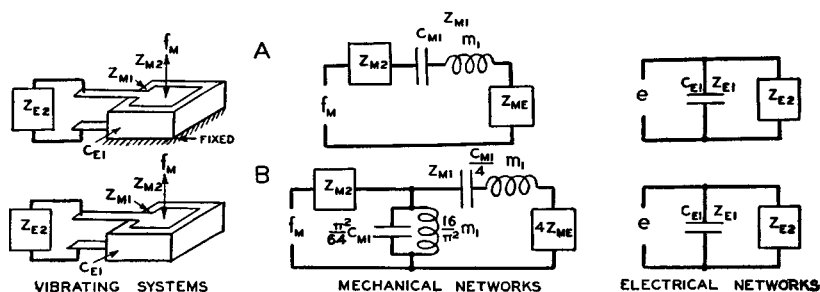

FIG. 9.8. Piezoelectric generating systems. A. Crystal fixed on one end and driven on the other. B. Crystal free on one end and driven on the other. In the mechanical networks: f_M , the driving force. z_{ME} , the mechanical rectilinear impedance due to the electrical circuit. z_{M2} , the mechanical rectilinear impedance of the external mechanical load. z_{M1} , the mechanical rectilinear impedance of the crystal. m_1 and C_{M1} , the effective mass and compliance of the crystal. In the electrical circuits: e , the electromotive force generated across the crystal. z_{E1} , the damped electrical impedance of the crystal. $z_{E1} = 1/j\omega C_{E1}$. C_{E1} , the damped electrical capacitance of the crystal. z_{E2} , the electrical impedance of the external load.

electrical network of Fig. 9.8 can be obtained from equation 9.45 and the velocity.

CHAPTER X

THEOREMS

10.1. Introduction

A number of dynamical laws common to electrical, mechanical rectilinear, mechanical rotational and acoustical systems have been described in this book. There are other dynamical laws that are well known in electrical circuit theory which can be applied to mechanical and acoustical systems. It is the purpose of this chapter to illustrate the application of reciprocity, Thevenin's and superposition theorems to electrical, mechanical rectilinear, mechanical rotational and acoustical systems.

10.2. Reciprocity Theorems ¹

A. *Electrical Reciprocity Theorem.*—In an electrical system composed of the electrical elements of inductance, electrical capacitance and electrical resistance, let a set of electromotive forces $e_1', e_2', e_3' \dots e_n'$ all harmonic of the same frequency acting in n points in the invariable network, produce a current distribution $i_1', i_2', i_3' \dots i_n'$, and let a second set of electromotive forces $e_1'', e_2'', e_3'' \dots e_n''$ of the same frequency as the first produce a second current distribution $i_1'', i_2'', i_3'' \dots i_n''$. Then

$$\sum_{j=1}^n e_j' i_j'' = \sum_{j=1}^n e_j'' i_j' \quad 10.1$$

This theorem is valid provided the electrical system is invariable, contains no internal source of energy or unilateral device, linearity in the relations between electromotive forces and currents and complete reversibility in the elements, and provided the electromotive forces $e_1, e_2, e_3 \dots e_n$ are all of the same frequency.

¹ Ballentine, S., *Proc. I.R.E.*, Vol. 17, No. 6, p. 929, 1929. "Reciprocity in Electromagnetic and Other Systems."

In the simple case in which there are only two electromotive forces, as illustrated in the electrical system of Fig. 10.1, equation 10.1 becomes

$$e' i'' = e'' i' \quad 10.2$$

where e' , e'' and i' , i'' are the electromotive forces and currents depicted in the electrical system of Fig. 10.1.

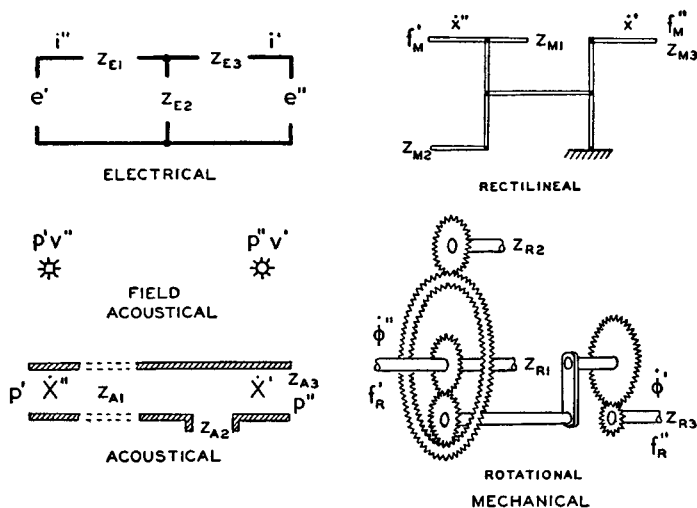

FIG. 10.1. Reciprocity in electrical, mechanical rectilinear, mechanical rotational and acoustical systems.

B. Mechanical Rectilinear Reciprocity Theorem.—In a mechanical rectilinear system composed of mechanical elements of mass, compliance and mechanical resistance, let a set of forces $f_{M1}', f_{M2}', f_{M3}' \dots f_{Mn}'$ all harmonic of the same frequency acting in n points in the system produce a velocity distribution $\dot{x}_1', \dot{x}_2', \dot{x}_3' \dots \dot{x}_n'$, and let a second set of forces $f_{M1}'', f_{M2}'', f_{M3}'' \dots f_{Mn}''$ of the same frequency as the first produce a second velocity distribution $\dot{x}_1'', \dot{x}_2'', \dot{x}_3'' \dots \dot{x}_n''$. Then

$$\sum_{j=1}^n f_{Mj}' \dot{x}_j'' = \sum_{j=1}^n f_{Mj}'' \dot{x}_j' \quad 10.3$$

This theorem is valid provided the mechanical system is invariable, contains no internal source of energy or unilateral device, linearity in the relations between forces and velocities and complete reversibility in

the elements, and provided the applied forces $f_{M1}, f_{M2}, f_{M3} \dots f_{Mn}$ are all of the same frequency.

In the simple case in which there are only two forces, as illustrated in the mechanical rectilinear system of Fig. 10.1, equation 10.3 becomes

$$f_M' \dot{x}'' = f_M'' \dot{x}' \tag{10.4}$$

where f_M', f_M'' and \dot{x}', \dot{x}'' are the forces and velocities depicted in the mechanical rectilinear system of Fig. 10.1.

C. Mechanical Rotational Reciprocity Theorem.—In a mechanical rotational system composed of mechanical rotational elements of moment of inertia, rotational compliance and mechanical rotational resistance, let a set of torques $f_{R1}', f_{R2}', f_{R3}' \dots f_{Rn}'$ all harmonic of the same frequency acting in n points in the system, produce a rotational velocity distribution $\dot{\phi}_1', \dot{\phi}_2', \dot{\phi}_3' \dots \dot{\phi}_n'$, and let a second set of torques $f_{R1}'', f_{R2}'', f_{R3}'' \dots f_{Rn}''$ of the same frequency as the first produce a second rotational velocity distribution $\dot{\phi}_1'', \dot{\phi}_2'', \dot{\phi}_3'' \dots \dot{\phi}_n''$. Then

$$\sum_{j=1}^n f_{Rj}' \dot{\phi}_j'' = \sum_{j=1}^n f_{Rj}'' \dot{\phi}_j' \tag{10.5}$$

This theorem is valid provided the mechanical rotational system is invariable, contains no internal source of energy or unilateral device, linearity in the relations between torques and rotational velocities, and provided the applied torques $f_{R1}, f_{R2}, f_{R3} \dots f_{Rn}$ are all of the same frequency.

In the simple case in which there are only two torques, as illustrated in the mechanical rotational system of Fig. 10.1, equation 10.5 becomes

$$f_R' \dot{\phi}'' = f_R'' \dot{\phi}' \tag{10.6}$$

where f_R', f_R'' and $\dot{\phi}', \dot{\phi}''$ are the torques and angular velocities depicted in the mechanical rotational system of Fig. 10.1.

*D. Acoustical Reciprocity Theorem.*²—From equation ³ 1.4 of “The Elements of Acoustical Engineering”

$$\frac{dv}{dt} + \frac{1}{\rho} \text{grad } p_0 = 0 \tag{10.7}$$

² Rayleigh, “Theory of Sound,” Vol. II, p. 145, MacMillan and Co., London, 1926.

³ Olson, “Elements of Acoustical Engineering,” D. Van Nostrand Co., New York, 1940.

Consider two independent sets of pressures p' , p'' and particle velocities v' and v'' . Multiply equation 10.4 by the p and v of the other set.

$$v'' \frac{dv'}{dt} - v' \frac{dv''}{dt} + \frac{1}{\rho} v'' \operatorname{grad} p_0' - \frac{1}{\rho} v' \operatorname{grad} p_0'' = 0 \quad 10.8$$

If p and v vary as a harmonic of the time, equation 10.5 becomes

$$v' \operatorname{grad} p_0'' - \frac{1}{\rho} v' \operatorname{grad} p_0'' = 0 \quad 10.9$$

There is the following relation:

$$v \operatorname{grad} p = \operatorname{div} vp - p \operatorname{div} v \quad 10.10$$

From equations 1.9 and 1.10 of "The Elements of Acoustical Engineering"

$$-\frac{1}{\gamma p_0} \frac{\partial p}{\partial t} + \operatorname{div} v = 0 \quad 10.11$$

From equations 10.8, 10.9 and 10.10

$$\operatorname{div} (v'' p_0' - v' p_0'') = 0 \quad 10.12$$

The relation of equation 10.12 is for a point. Integration of equation 10.12 over a region of space gives

$$\iiint (v'' p_0' - v' p_0'') ds = 0 \quad 10.13$$

If, in an acoustical system comprising a medium of uniform density and propagating irrotational vibrations of small amplitude, a pressure p' produces a particle velocity v' and a pressure p'' produces a particle velocity v'' , then

$$\iiint (v'' p' - v' p'')_n ds = 0 \quad 10.14$$

where the surface integral is taken over the boundaries of the volume.

In the simple case in which there are only two pressures, as illustrated in the free field acoustical system of Fig. 10.1, equation 10.14 becomes

$$p' v'' = p'' v' \quad 10.15$$

where p' , p'' and v' , v'' are the pressures and particle velocities depicted in the free field acoustical system of Fig. 10.1.

The above theorem is applicable to all acoustical problems. However, the above theorem can be restricted to lumped constants as follows: In an acoustical system composed of inertance, acoustical capacitance and acoustical resistance let a set of pressures $p_1', p_2', p_3' \dots p_n'$ all harmonic of the same frequency acting in n points in the system, produce a volume current distribution $\dot{X}_1, \dot{X}_2, \dot{X}_3 \dots \dot{X}_n$, and let a second set of pressures $p_1'', p_2'', p_3'' \dots p_n''$ of the same frequency as the first, produce a second volume current distribution $\dot{X}_1'', \dot{X}_2'', \dot{X}_3'' \dots \dot{X}_n''$. Then

$$\sum_{j=1}^n p_j' \dot{X}_j'' = \sum_{j=1}^n p_j'' \dot{X}_j' \quad 10.16$$

This theorem is valid provided the acoustical system is invariable, contains no internal source of energy or unilateral device, linearity in the relations between pressures and volume currents and complete reversibility in the elements, and provided the applied pressures $p_1, p_2, p_3 \dots p_n$ are all of the same frequency.

In the simple case in which there are only two pressures, as illustrated in the acoustical system of lumped constants in Fig. 10.1, equation 10.16 becomes

$$p' \dot{X}'' = p'' \dot{X}' \quad 10.17$$

where p', p'' and \dot{X}', \dot{X}'' are the pressures and volume currents depicted in the acoustical system of lumped constants in Fig. 10.1.

E. *Mechanical-Acoustical Reciprocity Theorem.*—In an interconnected mechanical-acoustical system let a set of forces $f_{M1}' \dots f_{Mn}'$ act in the mechanical system, and a set of pressures $p_1' \dots p_n'$ act in the acoustical system with the resultant velocities $\dot{x}_1' \dots \dot{x}_n'$ in the mechanical system and with the resultant volume currents $\dot{X}_1' \dots \dot{X}_n'$ in the acoustical system; let also, f'', \dot{x}'', p'' and \dot{X}'' represent a second set of such forces, velocities, pressures and volume currents. Then

$$\sum_{j=1}^n (f_{Mj}' \dot{x}_j'' + p_j' \dot{X}_j'') = \sum_{j=1}^n (f_{Mj}'' \dot{x}_j' + p_j'' \dot{X}_j') \quad 10.18$$

In the simple case in which there is only one force in the mechanical system and one pressure in the acoustical system

$$f_M' \dot{x}'' = p'' \dot{X}' \quad 10.19$$

Equation 10.19 states that if a unit force f_M' in the mechanical system produces a certain volume current X' in the acoustical system, then a unit pressure p'' acting in the acoustical system will produce a velocity \dot{x}'' in the mechanical system which is numerically the same as the volume current previously produced in the acoustical system.

The mechanical-acoustical reciprocity theorem is illustrated in Fig. 10.2A.

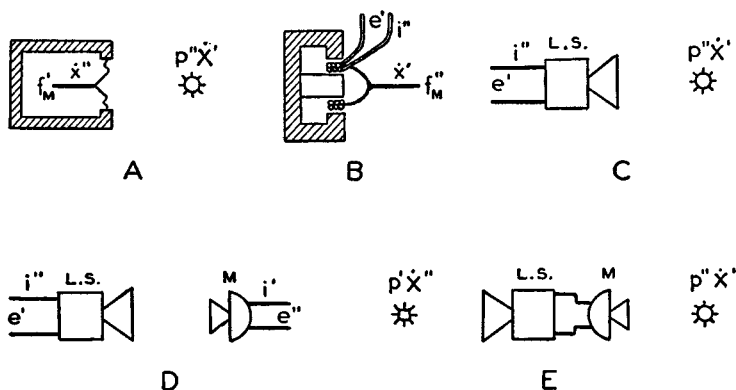

FIG. 10.2. Reciprocity in the following systems depicted above:

- A. Mechanical-acoustical.
- B. Electrical-mechanical.
- C. Electrical-mechanical-acoustical.
- D. Electrical-mechanical-acoustical-mechanical-electrical.
- E. Acoustical-mechanical-electrical-mechanical-acoustical.

F. *Electrical-Mechanical Reciprocity Theorem.*—In an interconnected electrical-mechanical system let a set of electromotive forces $e_1' \dots e_n'$ act in the electrical system, and a set of forces $f_{M1}' \dots f_{Mn}'$ act in the mechanical system with the resultant currents $i_1' \dots i_n'$ in the electrical system and with the resultant velocities $\dot{x}_1' \dots \dot{x}_n'$ in the mechanical system; let also, e'', i'', f_{Mj}'' and \dot{x}'' represent a second set of electromotive forces, currents, forces and velocities. Then

$$\sum_{j=1}^n (e_j' i_j'' + f_{Mj}' \dot{x}_j'') = \sum_{j=1}^n (e_j'' i_j' + f_{Mj}'' \dot{x}_j') \quad 10.20$$

In the simple case in which there is only one electromotive force in the electrical system and one force in the mechanical system

$$e' i'' = f_{M}'' \dot{x}' \quad 10.21$$

Equation 10.21 states that if a unit electromotive force e' in the electrical system produces a certain velocity \dot{x}' in the mechanical system, then a unit force f_M'' in the mechanical system will produce a current i'' in the electrical system which is numerically the same as the velocity previously produced in the mechanical system.

The electrical-mechanical reciprocity theorem is illustrated in Fig. 10.2B.

G. Electrical-Mechanical-Acoustical Reciprocity Theorem.—Since reciprocity relations hold in electrical-mechanical and mechanical-acoustical systems, they will also hold the three systems interconnected in the order electrical, mechanical, acoustical. This type of system embraces practically all electroacoustic transducers.

For the simple case of a pressure p' in a sound field producing a current i' in the electrical system and a voltage e'' in the electrical system producing a volume current \dot{X}'' in the sound field the reciprocity relation may be written

$$\iint (p' \dot{X}'') ds = e'' i' \quad 10.22$$

Equation 10.23 states that if, in the electrical system of a loud speaker, a generator of electromotive force e'' produces, at a point in a sound field, a volume current \dot{X}'' , than a numerically equal pressure in the sound field at that point will produce a current i' in the electrical system equal to the previously produced volume current \dot{X}'' in the sound field.

The electrical-mechanical-acoustical reciprocity theorem is illustrated in Fig. 10.2C.

H. Electrical-Mechanical-Acoustical-Mechanical-Electrical Reciprocity Theorem.—In most cases in the reproduction of sound the original sound is converted into electrical energy by a microphone which is usually an acoustical, mechanical, electrical transducer. Then it is converted back into acoustical energy by means of a loud speaker or an electrical, mechanical, acoustical transducer.

If both microphone and loud speaker are reversible and the air is the connecting medium, as shown in Fig. 10.2D, and if an electromotive force e' in the loud speaker will produce a current i' in the microphone, then an equal electromotive force e'' in the microphone will produce the same current i'' in the loud speaker. This may be expressed as

$$e' i'' = e'' i' \quad 10.23$$

I. *Acoustical-Mechanical-Electrical-Mechanical-Acoustical Reciprocity Theorem.*—If both microphone and loud speaker are reversible and the two connected electrically, as shown in Fig. 10.2E, and if a pressure p' at a point in the vicinity of the microphone will produce a volume current \dot{X}' at a point in the vicinity of the loud speaker, then an equal pressure p'' at the same point in the vicinity of the loud speaker will produce the same volume current \dot{X}'' at the same point in the vicinity of the microphone. This may be expressed as

$$p' \dot{X}'' = p'' \dot{X}' \quad 10.24$$

10.3. Thevenin's Theorems

A. *Thevenin's Electrical Theorem.*—If an electrical impedance z_E be connected between any two points in an electrical circuit, the current i through this electrical impedance is the electromotive force e between the points prior to the connection divided by the sum of the electrical impedance z_E and the electrical impedance z_E' , where z_E' is the electrical impedance of the circuit measured between the two points prior to connecting z_E .

B. *Thevenin's Mechanical Rectilinear Theorem.*—If a mechanical rectilinear impedance z_M be connected at any point in a mechanical rectilinear system, the resultant velocity of this mechanical rectilinear impedance is the product of the velocity and mechanical rectilinear impedance z_M' of the system both measured at the point prior to the connection divided by the sum of the mechanical rectilinear impedances z_M and z_M' .

C. *Thevenin's Mechanical Rotational Theorem.*—If a mechanical rotational impedance z_R be connected at any point in a mechanical rotational system, the resultant angular velocity of this mechanical rotational impedance is the product of the angular velocity and mechanical rotational impedance z_R' of the system both measured at the point prior to the connection divided by the sum of the mechanical rotational impedances z_R and z_R' .

D. *Thevenin's Acoustical Theorem.*—If an acoustical impedance z_A be connected at any point in an acoustical system, the volume current \dot{X} in this acoustical impedance is the pressure p at the point prior to the connection divided by the sum of the acoustical impedance z_A and the acoustical impedance z_A' , where z_A' is the acoustical impedance at the point prior to connecting z_A .

10.4. Superposition Theorem

Consider the simultaneous action of a number of electromotive forces, forces, torques or pressures distributed throughout an electrical, mechanical rectilinear, mechanical rotational or acoustical system. The current, velocity, angular velocity or volume current at any point or the electromotive force, force, torque or pressure at a location is the sum of the currents, velocities, angular velocities or volume currents or electromotive forces, forces, torques or pressures at these locations which would exist if each source were considered separately. Each source, save the one being considered, must be replaced by a unit of equivalent internal electrical, mechanical rectilinear, mechanical rotational or acoustical impedance.

CHAPTER XI

APPLICATIONS

11.1. Introduction

The fundamental principles relating to electrical, mechanical rectilinear, mechanical rotational and acoustical analogies have been established in the preceding chapters. Employing these fundamental principles the vibrations produced in mechanical and acoustical systems due to impressed forces may be solved as follows: Draw the electrical network which is analogous to the problem to be solved. Solve the electrical network by conventional electrical circuit theory. Convert the electrical answer into the original system. In this procedure any problem involving vibrating systems is reduced to the solution of an electrical network. A complete treatment of the examples of the use of analogies in the solution of problems in mechanical and acoustical systems is beyond the scope of this book. However, a few typical examples described in this chapter will serve to illustrate the principles and method.

11.2. Automobile Muffler

The sound output from the exhaust of an automobile engine contains all audible frequencies in addition to frequencies below and above the audible range. The purpose of a muffler is to reduce the audible exhaust sound output. An ideal muffler should suppress all audible sound which issues from the exhaust without increasing the exhaust back pressure.

The original mufflers consisted essentially of a series of chambers which increased progressively in volume. The idea was to allow the gases to expand and thereby reduce the noise. Actually it was a series of acoustical capacitances. This muffler is quite effective. However, by the application of acoustic principles an improved muffler has been developed in which the following advantages have been obtained: smaller size, higher attenuation in the audible frequency range and reduc-

tion of engine back pressure. A cross-sectional view of the improved muffler is shown in Fig. 11.1. The acoustical network¹ shows that the system is essentially a low pass filter. The main channel is of the same diameter as the exhaust pipe. Therefore, there is no increase in acoustical impedance to direct flow as compared to a plain pipe. In order not to impair the efficiency of the engine it is important that the muffler does not increase the acoustical impedance to subaudible frequencies. The system of Fig. 11.1 can be designed so that the subaudible frequencies

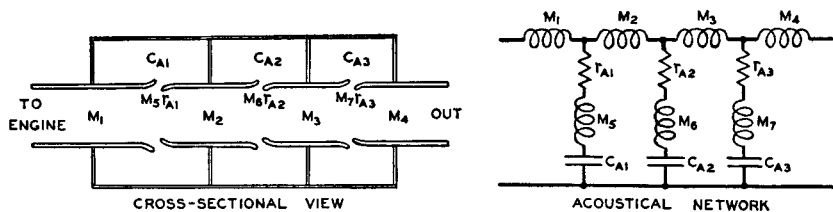

FIG. 11.1. Cross-sectional view and acoustical network of an automobile muffler.

are not attenuated and at the same time introduce high attenuation in the audible frequency range.

The terminations at the two ends of the network are not ideal. Therefore it is necessary to use shunt arms tuned to different frequencies in the low portion of the audible range. Acoustic resistance is obtained by employing slit type openings into the side chambers.

In a development of this kind the nature of sound which issues from the exhaust is usually determined. From these data the amount of suppression required in each part of the audible spectrum may be ascertained. From these data and the terminating acoustical impedances the

¹ In the illustrations in the preceding chapters the elements in the electrical network have been labeled r_E , L and C_E . However, in using analogies in actual practice the conventional procedure is to label the elements in the analogous electrical network with r_M , m and C_M for the mechanical rectilinear system, with r_R , I and C_R for a mechanical rotational system with r_A , M and C_A for an acoustical system. This procedure will be followed in this chapter in labeling the elements of the analogous electrical circuit. It is customary to label this network with the caption "analogous electrical network of the mechanical system" (or of the rotational system or of the acoustical system) or with the caption "mechanical network" (or rotational network or acoustical network). The latter convention will be used in this chapter. When there is only one path, circuit will be used instead of network.

network can be developed. In general, changes are required to compensate for approximations. In this empirical work the acoustical network serves as a guide in directing the appropriate changes.

11.3. Electric Clipper

An electric clipper is shown schematically in Fig. 11.2. The driving system is the unpolarized type described in section 8.3. The actuating

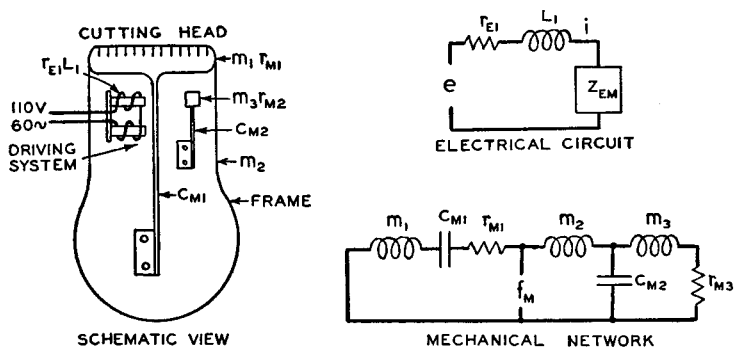

FIG. 11.2. Schematic view, electrical circuit and mechanical network of an electric clipper. In the electrical circuit: e , the alternating current line voltage. r_{E1} and L_1 , the electrical resistance and inductance of the coil. z_{EM} , the motional electrical impedance of the driving system. In the mechanical circuit: f_M , the driving force. r_{M1} , m_1 and C_{M1} , the mechanical rectilinear resistance, mass and compliance of the resonant cutter. m_2 , the mass of the frame. r_{M2} , m_3 and C_{M2} , the mechanical rectilinear resistance, mass and compliance of the shunt resonant system.

voltage is 110 volts 60 cycles. Therefore the frequency of the driving force is 120 cycles. This driving force acts on both the resonant clipper and the frame. The mechanical network shows that the amplitude of the frame m_2 will decrease as the mass of the frame is increased. However, the mass m_2 cannot be increased without limit because the clipper must be light so that it can be easily handled. For a suitable weight from this standpoint the vibration is too great. This vibration can be reduced by the introduction of a shunt resonant mechanical system. The mechanical rectilinear impedance of a shunt resonant mechanical circuit is very large at the resonant frequency. If this shunt mechanical circuit is tuned to 120 cycles the frame of the clipper will remain practically motionless. The mechanical network illustrates the action.

11.4. Direct Radiator Loud Speaker

The direct radiator type loud speaker shown in Fig. 11.3 is almost universally used for radio and phonograph reproduction. The mechanical circuit of this loud speaker is also shown in Fig. 11.3. The mechanical rectilinear impedance at the point f_M can be determined from the mechanical circuit. Then the motional electrical impedance can be determined from equation 8.7. The current in the voice coil can be deter-

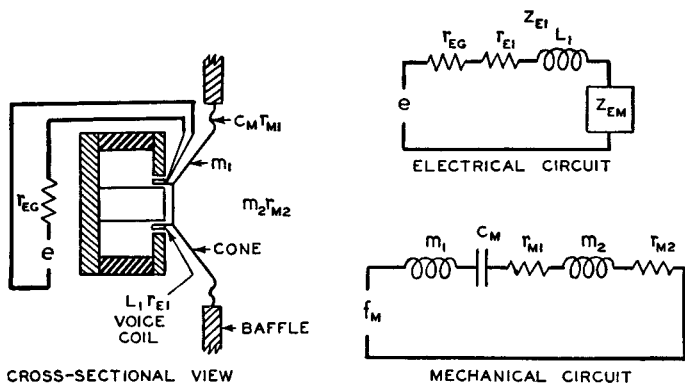

FIG. 11.3. Cross-sectional view, electrical circuit and mechanical circuit of a direct radiator dynamic loud speaker. In the electrical circuit: e , the open circuit voltage of the generator or vacuum tube. r_{EG} , the electrical resistance of the generator or vacuum tube. r_{EI} and L_1 , the electrical resistance and inductance of the voice coil. z_{EM} , the motional electrical impedance of the driving system. In the mechanical circuit: m_1 , the mass of the cone. r_{M1} and C_1 , the mechanical rectilinear resistance and compliance of the suspension. m_2 and r_{M2} , the mass and mechanical rectilinear resistance of the air load.

mined from the electrical circuit of Fig. 11.3. The mechanical driving force can be determined from equation 8.1. The velocity can be determined from the mechanical circuit of Fig. 11.3 as follows:

$$\dot{x} = \frac{f_M}{z_{MT}} \tag{11.1}$$

where z_{MT} = total mechanical impedance at the point f_M , in mechanical ohms, and
 f_M = driving force, in dynes.

The sound power output, in ergs, is given by

$$P = r_M \dot{x}^2 \quad 11.2$$

where r_M = mechanical radiation resistance, in mechanical ohms,
 \dot{x} = velocity of the cone, in centimeters per second.

The object ² is to select the constants so that the power output as given by equation 11.2 is independent of the frequency over the desired frequency range.

11.5. Rotational Vibration Damper

In reciprocating engines and other rotating machinery rotational vibrations of large amplitude occur at certain speeds. These rotational

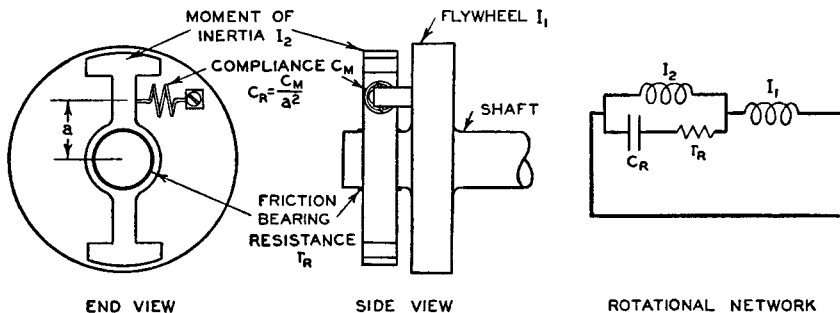

FIG. 11.4. Flywheel and vibration damper. In the mechanical network: I_1 , the moment of inertia of the flywheel. I_2 the moment inertia of the damper. C_R , the rotational compliance of the damper. r_R , the mechanical rotational resistance between the damper and the shaft.

vibrations are sometimes of such high amplitude that the shafts will fail after a few hours of operation. A number of rotational vibration dampers have been developed for reducing these rotational vibrations. It is the purpose of this section to describe one of these systems for controlling the vibrations in a rotational system. The simple vibration damper, shown in Fig. 11.4, is used to control the vibrations of the fly-

² For a specific description of and expressions for the elements of the mechanical system see H. F. Olson, "Elements of Acoustical Engineering," D. Van Nostrand Co., New York, 1940. In this book all types of acoustical vibrating systems are analyzed by the use of analogies. These systems include microphones, loud speakers, phonograph pickups, telephone receivers, measuring systems, etc.

wheel. The damper consists of a moment of inertia I_2 rotating on a shaft with a mechanical rotational resistance r_R . The moment of inertia is coupled to the flywheel by a spring of compliance C_M . The rotational compliance is $C_R = C_M/a^2$, where a is the radius at the point of attachment of the spring. This system forms a shunt mechanical rotational circuit. The shunt mechanical rotational circuit is tuned to the frequency of the vibration. Since the mechanical rotational impedance of a shunt resonant rotational circuit is very high at the resonant frequency the angular velocity of the vibration of the flywheel will be reduced. A consideration of the mechanical rotational network illustrates the principle of the device. This is one example of the many types of vibration dampers for use in absorbing rotational vibrations. The action of these systems may also be analyzed by the use of analogies.

11.6. Machine Vibration Isolator

The vibration of a machine is transmitted from its supports to all parts of the surrounding building structure. In many instances this

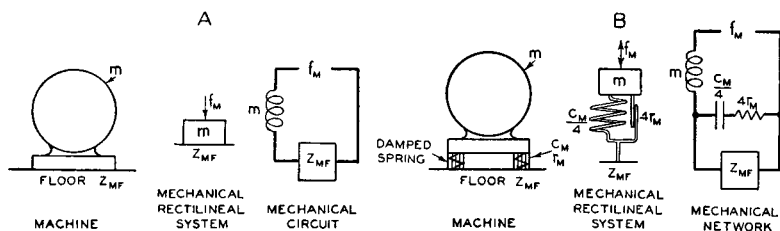

FIG. 11.5. Machine vibration isolator. A. Machine mounted directly upon the floor. In the mechanical rectilinear system and mechanical circuit: m , the mass of the machine. z_{MF} , the mechanical rectilinear impedance of the floor. f_M , the vibrating driving force developed by the machine. B. Machine mounted upon an isolating system. In the mechanical rectilinear system and mechanical network: m , the mass of the machine. $C_M/4$ and $4r_M$, the compliance and mechanical rectilinear resistance of the four damped spring mountings. z_{MF} , the mechanical rectilinear impedance of the floor. f_M , the vibrating driving force developed by the machine.

vibration may be so intense that it is intolerable. For these conditions the machine may be isolated from the base or floor upon which it is placed by introducing a mechanical isolating network.

A machine mounted directly on the floor is shown in Fig. 11.5A. The mechanical rectilinear system and the mechanical network for vertical vibrations is shown in Fig. 11.5A. The driving force f_M is due to the

vibrations of the machine. The mechanical network shows that the only isolation in the system of Fig. 11.5A is due to the mass of the machine.

In the simple isolating system shown in Fig. 11.5B the machine is mounted on damped springs. The compliance and the mechanical rectilinear resistance of the support is C_M and r_M . Since there are four supports, these values become $C_M/4$ and $4r_M$ in the mechanical rectilinear system and mechanical network for vertical vibrations. The mechanical network depicts the action of the shunt circuit in reducing the force of the vibration transmitted to the floor z_{MF} .

11.7. Mechanical Refrigerator Vibration Isolator

In the mechanical refrigerator a motor is used to drive a compressor. Since the refrigerator is a home appliance it is important that the vibra-

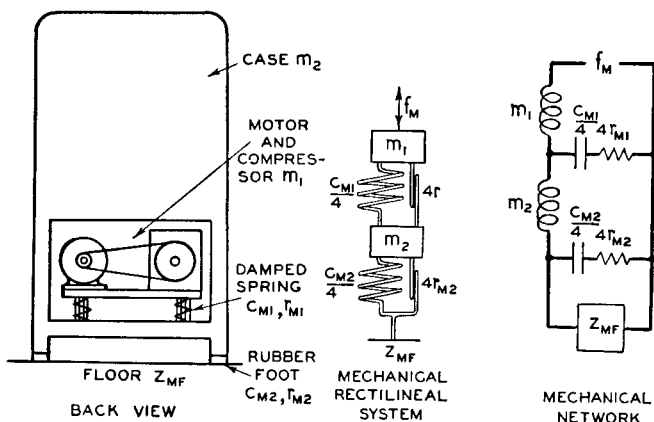

FIG. 11.6. Mechanical refrigerator vibration isolator. In the mechanical rectilinear system and the mechanical network: z_{MF} , the mechanical rectilinear impedance of the floor. $C_{M2}/4$ and $4r_{M2}$, the compliance and mechanical rectilinear resistance of the four rubber feet. m_2 , the mass of the case. $C_{M1}/4$ and $4r_{M1}$, the compliance and mechanical rectilinear resistance of the four damped springs. m_1 , the mass of the motor and compressor. f_M , the vibrating driving force developed by the machine.

tion and noise produced by the motor and compressor be as low in amplitude as possible. These vibrations may be suppressed by the use of an isolating mechanical network. The mechanical system, shown in Fig. 11.6, consists of the following elements: m_1 , the mass of the motor and

compressor. C_{M1} and r_{M1} , the compliance and the mechanical rectilinear resistance of the springs and damping material entwined in the springs. m_2 , the mass of the case. C_{M2} and r_{M2} , the compliance and the mechanical rectilinear resistance of the rubber feet. z_{MF} , the mechanical rectilinear resistance of the floor. Since there are four isolating supports for the motor and compressor and four feet on the refrigerator, the elements in the shunt circuits become $C_{M1}/4$ and $4r_{M1}$ for the isolating supports and $C_{M2}/4$ and $4r_{M2}$ for the rubber feet in the mechanical rectilinear system and the mechanical network. The mechanical network illustrates how the shunt circuit elements $C_{M1}/4$, $4r_{M1}$ and $C_{M2}/4$, $4r_{M2}$ reduce the force delivered to the floor. The shunt circuit elements $C_{M1}/4$ and $4r_{M1}$ also reduces the force delivered to the case of the refrigerator and thereby lessens the air-borne noises.

11.8. Shockproof Instrument Mounting

In order to obtain the maximum accuracy and reliability from galvanometers and other similar instruments of high sensitivity it is necessary that the mounting for the instrument be free from vibrations. Very often these instruments must be used in buildings in which the entire structure is vibrating. Any instrument support directly connected to the building will vibrate and will in turn transmit this vibration to the instrument. Under these conditions the performance of the instrument will be erratic. The instrument may be isolated from the building vibrations by means of a mechanical network of the type shown in Fig. 11.7. The instrument table legs are mounted on resilient supports which are both a compliance C_{M1} and a resistance r_{M1} . This support reduces the vibration of the table m_1 . The instrument is isolated further by the compliance C_{M2} and the mass m_2 . A mechanical rectilinear resistance r_{M2} in the form of a dash pot is used to damp the vibrations of the mass m_2 . The driving force at each of the four legs is f_M . Since there are four legs and four isolating supports, the elements in this shunt circuit become $C_{M1}/4$ and $4r_{M1}$ and the driving force becomes $4f_M$ in the mechanical rectilinear system and the mechanical network. The mechanical network illustrates the action of the vibrating system. The velocity of the mass m_2 is very small compared to the velocity of the floor due to the series mass elements and shunt compliance and mechanical rectilinear resistance elements. The mechanical network of Fig. 11.7 depicts the vertical modes of vibration. Of course, the system in Fig.

11.7 may vibrate in many other modes which may be solved by similar analysis but, in general, the vertical motion is the most violent and troublesome.

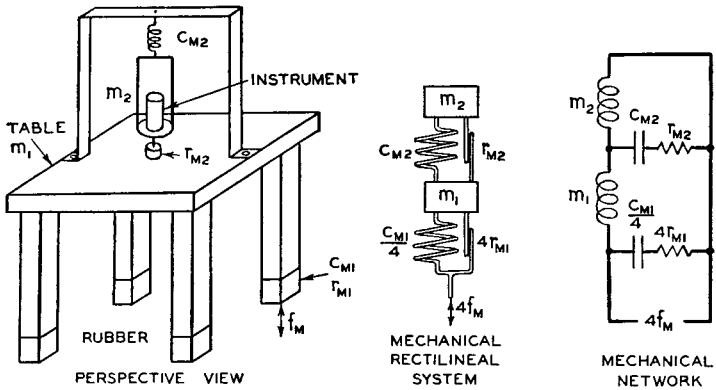

FIG. 11.7. Shockproof instrument mounting. In the mechanical rectilinear system and mechanical network: $4f_M$, the combined driving force at the four legs. $C_{M1}/4$ and $4r_{M1}$, the compliance and mechanical rectilinear resistance of the four feet. C_{M2} , the compliance of the spring suspension. r_{M2} , the mechanical rectilinear resistance of the dash pot. m_2 , the mass of the instrument and carriage.

11.9. Automobile Suspension System

The riding qualities of an automobile depend primarily upon the degree of isolation of the passenger from all types of vibration. One of the principal sources of vibration is due to the uneven contour of the road over which the automobile travels. The objective of automobile designers is to reduce the vibration of the passenger to a practical minimum. A schematic view of an automobile is shown in Fig. 11.8. This system has many degrees of freedom, both rectilinear and rotational. The system depicted in the mechanical rectilinear system and mechanical network of Fig. 11.8 assumes that the forces at each of the four wheels are equal in both amplitude and phase and that vibrations occur in a vertical line. The vibrating system consists of the following elements: f_M , the driving force at each tire. C_{M1} and r_{M1} , the compliance and mechanical rectilinear resistance of the tires. m_1 , the mass of the tire, wheel and axle. C_{M2} , the compliance of the spring. r_{M2} , the mechanical rectilinear resistance of the shock absorber. m_2 , the mass of the frame, body, engine, etc. C_{M3} and r_{M3} , the compliance and mechanical rectilinear re-

sistance of the cushion. m_3 , the mass of the passenger. Since there are four tires, wheels, springs and shock absorbers, the elements corresponding to these parts in the mechanical rectilinear system and mechanical network are as follows: $4f_M$, the driving force. $C_{M1}/4$ and $4r_{M1}$ the compliance and mechanical rectilinear resistance of the tires. $C_{M2}/4$, the compliance of the springs. $4r_{M2}$, the mechanical rectilinear resistance of the shock absorbers. However, there is no change in the case of the

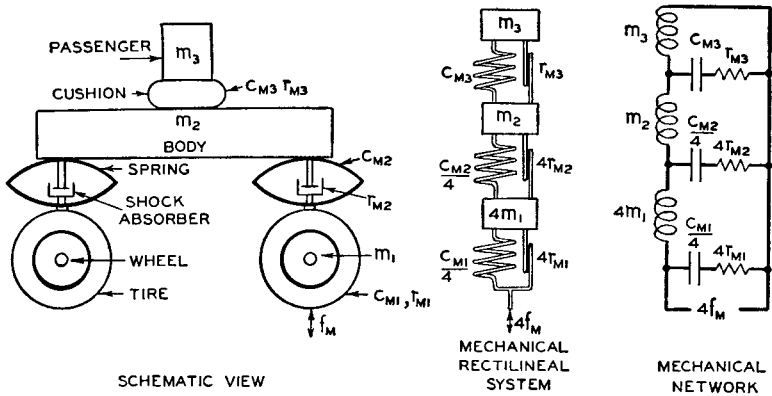

FIG. 11.8. Automobile suspension system. In the mechanical rectilinear system and mechanical network: $4f_M$, the combined driving force at the four tires. $C_{M1}/4$ and $4r_{M1}$, the compliance and mechanical rectilinear resistance of the four tires. $4m_1$, the mass of the four tires. $C_{M2}/4$, the compliance of the four springs. $4r_{M2}$, the mechanical rectilinear resistance of the four shock absorbers. m_2 , the mass of the frame, body and engine. C_{M3} and r_{M3} , the compliance and mechanical rectilinear resistance of the cushion. m_3 , the mass of the passenger.

m_2 , C_{M3} , r_{M3} and m_3 because these are single units in the schematic view. The mechanical rectilinear resistance of the tires is quite small. The mechanical rectilinear resistance of the springs is exceedingly small. A low frequency oscillation with very little damping occurs due to the resonance of the mass m_2 of the body with the compliances C_{M2} and C_{M1} of the springs and tires. This oscillation is excited by a wavy road bed and becomes very violent when the speed divided by the wavelength corresponds to the resonant frequency. A high frequency oscillation occurs due to the resonance of the mass m_2 of the wheels and axles with the compliances C_{M1} and C_{M2} of the tires and springs. This oscillation is excited by sharp discontinuities such as cobblestones. This resonance

becomes so violent in the absence of damping that the wheels leave the road. These uncontrolled oscillations require the introduction of some form of damping for reducing the amplitude. A system has been developed in the form of the hydraulic shock absorber, which controls the oscillations. It has been found that by the use of such damping means, the compliance of the springs could be increased by use of "softer" springs and the compliance of the tires increased by the use of balloon tires. Both of these expedients have improved the riding qualities as can be seen from a consideration of the mechanical network of Fig. 11.6. A further improvement in riding qualities has been obtained by the use of better designed cushions, that is, an appropriate ratio of compliance C_{M3} to mechanical rectilinear resistance r_{M3} .

The above brief description illustrates how one of the vibration problems in an automobile may be solved by the use of analogies. As already indicated, an automobile has several modes of vibration, both rectilinear and rotational. For example, each wheel may be excited separately which may introduce a rolling, pitching or swaying motion. All of these may be analyzed by the use of analogies. The individual effects may be superposed and the gross effect of all vibrations obtained. Most of the forces, developed at the tires, are of the impulsive and not the sinusoidal type. In these cases the information on transients in electrical circuits may be applied to the mechanical system as outlined in Chapter VII.

Supplementary Note: Electrical, mechanical rectilinear, mechanical rotational and acoustical ohms have been defined in the tables on pages 21, 22 and 23 and under the definitions of these impedances. To avoid any possibility of ambiguity, the explicit verbal definitions of these terms is listed below.

Electrical abohm.—An electrical resistance, reactance or impedance is said to have a magnitude of one abohm when an electromotive force of one abvolt produces a current of one abampere.

Mechanical Ohm.—A mechanical rectilinear resistance, reactance or impedance is said to have a magnitude of one mechanical ohm when a force of one dyne produces a velocity of one centimeter per second.

Rotational Ohm.—A mechanical rotational resistance, reactance or impedance is said to have a magnitude of one rotational ohm when a torque of one dyne centimeter produces an angular velocity of one radian per second.

Acoustical Ohm.—An acoustical resistance, reactance or impedance is said to have a magnitude of one acoustical ohm when a pressure of one dyne per square centimeter produces a volume current of one cubic centimeter per second.

INDEX

- Abampere**, 6
Abvolt, 5
Acoustical,
 capacitance, 10, 17, 18, 21, 23, 62, 76
 impedance, 9, 23
 narrow slit, 14
 ohm, 9, 10, 23, 190
 reactance, 10, 23
 resistance, 10, 13, 23
 system, 10, 25, 37
 transformer, 88
 wave filter, 92
Acoustomotive force, 6, 35
 effective, 6
 instantaneous, 6
 maximum, 6
 peak, 6
Angular velocity,
 effective, 7
 instantaneous, 7
 maximum, 7
 peak, 7
Applications, 180
Arbitrary force, 120
Automobile muffler, 180
Automobile suspension system, 188
- Basic frequency**, 4
Blocked electrical impedance, 126
- Capacitance**,
 acoustical, 10, 17, 18, 21, 23, 62, 76
 electrical, 8, 17, 18, 22, 23, 60, 74
Capacitive coupled systems and analogies, 45
Centimeter per second, 7
Clipper, electric, 182
- Compliance, 9, 17, 18, 21, 22, 23, 60, 61, 75
 rectilinear, 9, 17, 21, 22, 60, 75
 rotational, 9, 17, 18, 21, 23, 61, 75
Corrective networks, 52
 resistance, 85
 series, 86
 shunt, 86
 “T” type, 87
 “ π ” type, 87
series, 71
 capacitance and analogies, 74
 inductance and analogies, 72
 inductance and capacitance in parallel and analogies, 78
 inductance and capacitance in series and analogies, 76
 resistance, inductance and capacitance in parallel and analogies, 83
 resistance, inductance and capacitance in series and analogies, 80
shunt, 56
 capacitance and analogies, 60
 inductance and analogies, 58
 inductance and capacitance in parallel and analogies, 64
 inductance and capacitance in series and analogies, 62
 resistance, inductance and capacitance in parallel and analogies, 69
 resistance, inductance and capacitance in series and analogies, 67
Coupled systems and analogies, 45
Cubic centimeter per second, 7

- Current,
 effective, 7
 instantaneous, 6
 maximum, 7
 peak, 7
 Cycle, 4
- D'Alembert's principle**, 33
- Decibel, 11
- Definitions, 4
- Differential gear train, 55
- Dimensions, 20, 21, 22, 23, 24
- Dissipation, 29, 39
- Driving systems, 124
 electrodynamic, 124
 electromagnetic, 126
 electrostatic, 138
 magnetostriction, 141
 piezoelectric, 148
 polarized balanced armature, 134
 polarized reed armature, 130
 unpolarized armature, 127
- Duhamel's integral, 120
- Dyne, 5
- Dyne centimeter, 6
- Dyne per square centimeter, 6
- Effective**,
 acoustomotive force, 6
 angular velocity, 7
 current, 7
 electromotive force, 5
 force, 5
 mechanomotive force, 5
 rotatomotive force, 6
 sound pressure, 6
 torque, 6
 velocity, 7
 volume current, 8
- Electrical,
 abohm, 8, 22, 190
 capacitance, 8, 17, 18, 22, 23, 60, 74
 impedance, 8, 22
 blocked, 126
 normal, 126
- Electrical, impedance (Cont.)
 motional, 126
 ohm, 8, 22
 reactance, 8, 22
 resistance, 8, 12, 22
 system, 10, 25, 37
 transformer, 88
 wave filter, 92
- Electric clipper, 182
- Electrodynamic,
 driving system, 124
 generating system, 153
- Electromagnetic,
 driving system, 126
 polarized balanced armature, 134
 polarized reed armature, 130
 unpolarized armature, 127
 generating system, 155
 balanced armature, 157
 reed armature, 155
- Electromotive force, 5, 22, 33
 effective, 5
 instantaneous, 5
 maximum, 5
 peak, 5
- Electrostatic,
 driving system, 138
 generating system, 158
- Element, 10, 12, 19, 21, 22, 23
 acoustical, 13, 16, 18, 19, 21, 23
 electrical, 12, 15, 17, 19, 21, 22
 mechanical rectilinear, 13, 15, 17, 21, 22
 mechanical rotational, 13, 15, 18, 21, 23
- Energy,
 kinetic, 27, 38
 potential, 7, 39
- Epicyclic gear train, 54
- Equation, Lagrange's, 40
- Equation of motion, 30, 40
- Filters**, wave (see wave filters)
- Force, 5, 21, 22
 acoustomotive, 6, 35

- Force (Cont.)
 arbitrary, 120
 effective, 5
 electromotive, 5, 21, 33
 instantaneous, 5
 maximum, 5
 mechanomotive, 5, 34
 peak, 5
 rotatomotive, 6, 33
- Frequency, 4
 basic, 4
 fundamental, 4
 resonant, 32
- Gear** train, 54, 55
- Generating systems, 153
 electrodynamic, 153
 electromagnetic, 155
 balanced armature, 157
 reed armature, 155
 electrostatic, 158
 magnetostriction, 162
 piezoelectric, 165
- Harmonics**, 4
- Heaviside Operational Calculus, 106
- Impedance**,
 acoustical, 9, 23
 electrical, 8, 22
 blocked, 126
 normal, 126
 motional, 126
 mechanical, 8, 22, 23
 mechanical rectilinear, 8, 22
 mechanical rotational, 9, 23
 parallel, 52
 rotational, 9, 23
- Inductance, 8, 15, 21, 22, 58, 72
- Inductive coupled systems and analogies, 46
- Inertance, 10, 15, 16, 21, 23, 60, 74
- Inertia, moment of, 9, 15, 21, 23, 59, 73
- Instantaneous,
 acoustomotive force, 6
- Instantaneous (Cont.)
 electromotive force, 5
 force, 5
 mechanomotive force, 5
 rotatomotive force, 6
 sound pressure, 6
 torque, 6
 velocity, 7
 volume current, 8
- Instrument, shock proof mounting, 187
- Integral, Duhamel's, 120
- Introduction, 1
- Joule** effect, magnetostriction, 142
- Kinetic** energy, 27, 38
- Kirchhoff's law, 33
- Lagrange's** equations, 40
- Law, Kirchhoff's, 33
- Line, 52, 56, 71
- Loud speaker, 183
- Machine** vibration isolator, 185
- Magnetostriction,
 driving system, 141
 generating system, 162
- Mass, 9, 15, 21, 22, 58, 73
- Maximum,
 acoustomotive force, 6
 angular velocity, 7
 current, 7
 electromotive force, 5
 force, 34
 mechanomotive force, 5
 rotatomotive force, 6
 sound pressure, 6
 torque, 6
 velocity, 7
 volume current, 8
- Mechanical,
 impedance, 8, 22, 23
 ohm, 8, 9, 22, 190
 reactance, 9, 22, 23
 rectilinear impedance, 8, 22

Mechanical (Cont.)

- rectilinear reactance, 9, 22
 - rectilinear resistance, 9, 13, 22
 - rectilinear system, 10, 41
 - rectilinear wave filters, 92
 - resistance, 9, 13, 22, 23
 - rotational impedance, 9, 23
 - rotational reactance, 9, 23
 - rotational resistance, 9, 13, 23
 - rotational system, 10, 42
 - rotational wave filters, 92
 - transformer, 88
- Mechanical refrigerator vibration isolator, 186
- Moment of inertia, 9, 15, 21, 23, 59, 73
- Motional electrical impedance, 125, 126
- Muffler, automobile, 180

Narrow slit, 14

- Networks, 2, 52, 125, 181 (see corrective networks)
- acoustical, 52, 125, 181
 - electrical, 52, 125, 181
 - mechanical rectilinear, 52, 125, 181
 - mechanical rotational, 52, 125, 181
 - resistance corrective, 85
 - series corrective, 71
 - shunt corrective, 56
- Normal electrical impedance, 126

Octave, 4**Ohm,**

- acoustical, 9, 10, 23, 190
 - electrical, 8, 22, 190
 - mechanical, 8, 9, 22, 190
 - rotational, 9, 23, 190
- One degree of freedom, 25
- acoustical, 25
 - electrical, 25
 - mechanical rectilinear, 25
 - mechanical rotatomotive, 25

Operational Calculus, Heaviside, 106**Parallel,**

- impedances, 52, 64, 69
 - acoustical, 52, 64, 69
 - electrical, 52, 64, 69
 - mechanical rectilinear, 52, 64, 69
 - mechanical rotatomotive, 52, 64, 69
- Peak,
- acoustomotive force, 6
 - angular velocity, 7
 - current, 7
 - electromotive force, 5
 - force, 5
 - mechanomotive force, 5
 - rotatomotive force, 6
 - sound pressure, 6
 - torque, 6
 - velocity, 7
 - volume current, 8
- Period, 4
- Periodic quantity, 4
- Piezoelectric,
- driving system, 148
 - generating system, 165
- " π " type network, 87
- Planetary gear train, 54
- Potential energy, 28, 39
- Pressure,
- sound, 6, 21, 23
 - static, 6

Quartz crystal, 148, 165**Radians per second, 7****Reactance,**

- acoustical, 10, 23
- electrical, 8, 22
- mechanical, 9, 22, 23
- mechanical rectilinear, 9, 22
- mechanical rotational, 9, 23
- rotational, 9

Reciprocity theorems (see theorems)**Resistance,**

- acoustical, 10, 13, 23
- electrical, 8, 12, 22

- Resistance (Cont.)
 mechanical, 9, 13, 22, 23
 mechanical rectilinear, 9, 13, 22
 mechanical rotational, 9, 13, 22
 networks, 85
 rotational, 9, 13, 23
- Resonant frequency, 32
- Rotational,
 compliance, 9, 17, 18, 21, 23, 61, 75
 impedance, 9, 23
 ohm, 9, 23, 190
 reactance, 9
 resistance, 9, 13, 23
- Rotational vibration damper, 184
- Rotatomotive force, 6, 35
 effective, 6
 instantaneous, 6
 maximum, 6
 peak, 6
- Series** corrective networks (see corrective networks)
- Shock proof instrument mounting, 187
- Shunt corrective networks (see corrective networks)
- Slit, 14
- Sound pressure, 6, 21, 23
 effective, 6
 instantaneous, 6
 maximum, 6
 peak, 6
- Static pressure, 6
- Stiffness, 18, 28
- Subharmonic, 5
- Superposition theorem, 179
- Suspension systems, automobile, 188
- Systems,
 acoustical, 10, 42
 coupled, 45
 electrical, 10, 41
 mechanical rectilinear, 10, 41
 mechanical rotational, 10, 42
 one degree of freedom, 25
 three degrees of freedom, 48
 two degrees of freedom, 37
- Table**, 21, 22, 23
- Theorems,
 reciprocity, 171
 acoustical, 173
 acoustical-mechanical-electrical-mechanical-acoustical, 178
 electrical, 171
 electrical-mechanical, 176
 electrical-mechanical-acoustical, 177
 electrical-mechanical-acoustical-mechanical-electrical, 177
 mechanical-acoustical, 175
 mechanical rectilinear, 172
 mechanical rotational, 173
 superposition, 179
- Thevenin's, 178
 acoustical, 178
 electrical, 178
 mechanical rectilinear, 178
 mechanical rotational, 178
- Three degrees of freedom, 37, 45
- Torque, 6, 21, 23
 effective, 6
 instantaneous, 6
 maximum, 6
 peak, 6
- Transducer, 11
- Transformer,
 acoustical, 88
 electrical, 88
 mechanical rectilinear, 88
 mechanical rotational, 88
- Transient response,
 electrical resistance and electrical capacitance in series and analogies, 111
 electrical resistance, inductance and electrical capacitance in series and analogies, 114
 inductance and electrical resistance in series and analogies, 107
- Transients, 105
 arbitrary force, 120
 Duhamel's integral, 122

- Transients (Cont.)
 - Heaviside's Calculus, 106
 - unit function, 106
- Transmission,
 - gain, 11
 - loss, 11
- "T" type network, 87
- Two degrees of freedom, 37, 45

- Unit function**, 106
- Units, 20, 21, 22, 23, 24

- Velocity**, 7, 22
 - angular, 7, 23
 - effective, 7
 - instantaneous, 7
 - linear, 7, 22
 - maximum, 7
 - peak, 7
- Vibration,
 - machine isolator, 185
 - mechanical refrigerator isolator, 186
 - rotational damper, 184

- Villari effect, magnetostriction, 143, 163
- Volume current, 8, 23
 - effective, 8
 - instantaneous, 8
 - maximum, 8
 - peak, 8

- Wave**, 5
- Wave filters,
 - band elimination, 92, 93, 101
 - band pass, 92, 93, 97
 - high pass, 92, 93, 95
 - low pass, 92, 93, 94
 - response characteristics, 93
- Wavelength, 5

- "X" cut quartz crystal, 148

- Young's modulus**, 144, 146, 147, 149, 150, 151, 163, 165, 167