

from JETEC release
#2284, Oct. 6, 1958

ADVANCE DATA
CHARACTERISTICS

GENERAL DATA

Focusing Method	Electrostatic
Deflection Method	Magnetic
Deflection Angles (Approx.)	
Horizontal	85 Degrees
Diagonal	90 Degrees
Phosphor	Aluminized P4
Fluorescence	White
Persistence	Short to Medium
Faceplate	Gray Filter Glass
Light Transmittance (Approx.)	74 Percent

ELECTRICAL DATA

Heater Voltage	6.3 Volts	
Heater Current	0.3 ± 5% Ampere	
Heater Warm-up Time ¹	11 Seconds	
Direct Interelectrode Capacitance (Approx.)		
Cathode to All Other Electrodes	5 μf	
Grid No. 1 to All Other Electrodes	6 μf	
External Conductive Coating to Anode ²	1500 μf	Max.
	1000 μf	Min.

MECHANICAL DATA

Minimum Useful Screen Dimensions	14 5/16 x 11 1/8 Inches
Minimum Useful Screen Area	149 Sq. Inches
Bulb	J133F or J133G
Bulb Contact (Recessed Small Cavity Cap)	J1-21
Base (Small Shell Duodecal 6-Pin)	B6-63
Basing	12L
Weight (Approx.)	13 Pounds

RATINGS

MAXIMUM RATINGS (Absolute Maximum Values)

Anode Voltage	17,600 Volts	dc
Grid No. 4 Voltage		
(Focusing Electrode)	-550 to +1100 Volts	dc
Grid No. 2 Voltage	550 Volts	dc
Grid No. 1 Voltage		
Negative Bias Value	155 Volts	dc
Negative Peak Value	220 Volts	
Positive Bias Value	0 Volts	dc
Positive Peak Value	2 Volts	
Peak Heater-Cathode Voltage		
Heater Negative with Respect to Cathode		
During Warm-up Period Not to Exceed		
15 Seconds	450 Volts	
After Equipment Warm-up Period	200 Volts	
Heater Positive with Respect to Cathode	200 Volts	

QUICK REFERENCE DATA

Television Picture Tube
17" Direct Viewed
Rectangular Glass Type
Spherical Faceplate
Gray Filter Glass
Magnetic Deflection
Electrostatic Focus
No Ion Trap
External Conductive Coating
Aluminized Screen
6.3 Volt, 300 Ma Heater

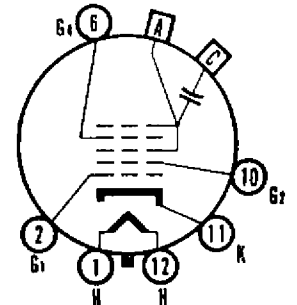
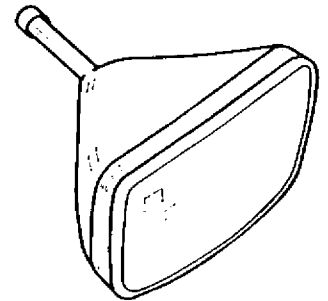

12-1

SYLVANIA ELECTRIC PRODUCTS INC.

TELEVISION PICTURE TUBE DIVISION
SENECA FALLS, NEW YORK

Prepared and Released By The
TECHNICAL PUBLICATIONS SECTION
EMPORIUM, PENNSYLVANIA

September 8, 1958

Page 1 of 3

SYLVANIA

17DCP4

Page 2

TYPICAL OPERATING CONDITIONS

Anode Voltage	14,000 Volts	dc
Grid No. 4 Voltage	-50 to +300 Volts	dc
Grid No. 2 Voltage	300 Volts	dc
Grid No. 1 Voltage Required for Cutoff ³	-35 to -72 Volts	dc

CIRCUIT VALUES

Grid No. 1 Circuit Resistance 1.5 Megohms Max.

NOTES:

1. Heater Warm-up Time is defined as the time required for the voltage across the heater to reach 80% of its rated value after applying four (4) times rated heater voltage to a circuit consisting of the tube heater in series with a resistance equal to three (3) times rated heater voltage divided by rated heater current.
2. External conductive coating must be grounded.
3. Visual extinction of focused raster. Extinction of stationary focused spot will require that these values be about 5 volts more negative.

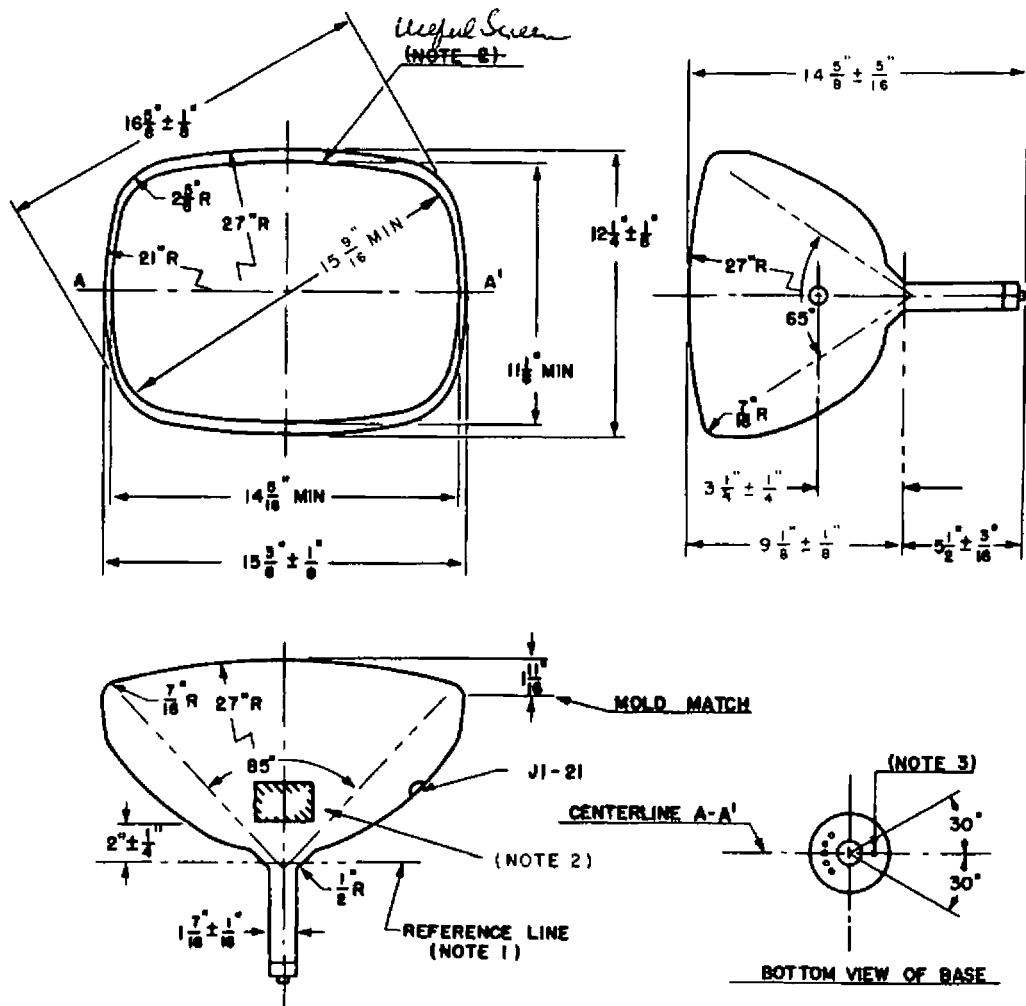

DIAGRAM NOTES:

1. Reference line is determined by the plane C-C' of the Reference Line Gauge (JETEC No. 116) when the gauge is seated on the glass cone.
2. Contact area for external conductive coating 2" x 2", located 90 degrees counterclockwise from anode contact as viewed from base end of tube.
3. Anode contact aligns with pin position No. 6 ± 30 degrees.

WARNING:

X-ray radiation shielding may be necessary to protect against possible danger of personal injury from prolonged exposure at close range if this tube is operated at higher than the manufacturer's Maximum Rated Anode Voltage or 16,000 volts, whichever is less.