

→ Specification MOS/CV.4018 incorporating MIL/E/1/83A Issue 2 dated 26-2-57.      & BS.448 To be read in conjunction with K.1006	<u>SECURITY</u>	
	<u>Specification</u> UNCLASSIFIED	<u>Valve</u> UNCLASSIFIED

→ indicates a change

TYPE OF VALVE - Gas-filled Tetrode (Reliable) CATHODE - Indirectly Heated ENVELOPE - Glass, unmetallised PROTOTYPE - 5727/2D21W	<u>MARKING</u> See K1001/4 <u>additional marking</u> 5727/2D21W
--	--

<u>RATINGS</u>		Relay, Grid Controlled Rect.	Modulator	Notes
Heater Voltage	(V)	6.3 ± 10%	6.3 <sup>+10%</sup> / <sub>-5%</sub>	
Heater Current	(A)	0.6	0.6	
Max Peak AC Anode Voltage	(V)		500	B
Max Peak Forward Anode Voltage	(V)	650	500	
Max Anode P.I.V.	(V)	1300	100	
Max G2 Voltage (Conduction)	(V)	-10	-10	
Max G1 Voltage (Conduction)	(V)	-10	-10	
Max Peak G2 Voltage (Non-conduction)	(V)	-100	-50	
Max Peak G1 Voltage (Non-conduction)	(V)	-100	-100	
Max Peak Heater-Cathode Voltage	(V)	-100 to +25	0	
Max G1 Circuit Resistance	(M)	10	0.5	
Min G2 Series Resistance	(k)		2	
Max G2 Series Resistance	(k)		25	
Max Peak Cathode Current	(A)	0.5	10	
Max Mean Cathode Current	(mA)	100	10	C
Max Peak G2 current	(mA)		20	
Max Peak G1 current	(mA)		20	
Max Mean G2 Current	(mA)	10		C
Max Mean G1 Current	(mA)	10		C
Max Pulse Duration	(us)		5	
Max Rate of Rise of Cathode Current	(A/us)		100	
Max p.r.f.	(pps)		500	
Max Duty Cycle	(Du)		0.001	
Max Ambient Temperature Range	(°C)	-75 to +90	-75 to +90	
Min Cathode Heating Time	(Sec)	10	10	

<u>NOTES</u>	<u>Connections</u>		
	Pin	Electrode	
A. All limiting values are absolute.  B. After the completion of a pulse, a 20 uSec delay is required before a positive voltage of more than 10V is applied.  C. Average over any interval of 30 seconds minimum.	1	g1 control grid	
	2	k cathode	
	3	h heater	
	4	h heater	
	5	g2 auxiliary grid	
	6	a anode	
	7	g2 auxiliary grid	
	<u>Dimensions</u>		
	Sec BS.448 Section B7G/2.1.3		
	Dimension mm	Min.	Max.
	A Seated height		54.0
	C Diameter	16.0	19.0
	D Overall length		61.0

# CV4018

MIL-E-1/83A  
25 July 1956  
SUPERSEDING  
MIL-E-1/83  
5 Feb. 1953

## INDIVIDUAL MILITARY SPECIFICATION SHEET

### ELECTRON TUBE, MINIATURE XENON THYRATRON, TETRODE

JAN-5727/2D21W

This specification sheet forms a part of the latest issue of Military Specification MIL-E-1.

Ratings: Absolute Maximum:	Conduction					Non-Conduction				Rg1 Meg	Rg2 Ohms	
	Ef V	epp v	epy v	epx v	Ec2 V	Ecl V	ec2 v	ecl v	ehk v		Min	Max
Relay, G controlled Rect.:	6.3/10%	—	650	1300	-10	-10	-100	-100	-100	10	1000	—
Pulse Modulator:	6.3/10% - 5% Note 1	500	500	100	-10	-10	- 50	-100	0	0.5	2000	25K
Test. Cond.:	6.3	—	—	—	0	—	—	—	—	—	—	—

Ratings: Absolute Maximum:	Ik a	Ik mA	ig2 ma	igl ma	Ig2 mA	Igl mA	tp us	dIk/dt a/us	prp pps	Du	TA °C	tk sec(min)
	Note 2		Note 2		Note 2	Note 2						
Relay, G controlled Rect.:	0.5	100	—	—	10	10	—	—	—	—	-75 to +90	20
Pulse Modulator:	10	10	20	20	—	—	5	100	500	.001	-75 to +90	20
Test. Cond.:	—	—	—	—	—	—	—	—	—	—	—	20

Cathode: Coated Unipotential  
Base: Miniature Button 7-pin, E7-1

Height: Max. 2-1/8 in.  
Diameter: Max. 3/4 in.

Pin No.: 1 2 3 4 5 6 7  
Element: g1 k h h g2 a g2

Envelope: T-5 1/2 (6-2)

The following tests shall be performed:

Ref.	Test	Conditions	ACL (%)	Insp. Level or Code	Sym.	LIMITS						Units
						Min.	LAL	Bogie	UAL	Max.	ALD	
<u>For miscellaneous requirements, see Paragraph 3.3, Inspection Instructions for Electron Tubes.</u>												
<u>Qualification Approval Tests</u>												
3.1	Qualification Approval:	Required for JAN Marking	—	—								
—	Cathode:	Coated Unipotential	—	—								
3.4.3	Base Connections:	E7-1	—	—								
4.9.20.3	Vibration (1):	No Voltages	—	—								
<u>Measurements Acceptance Tests, Part 1, Note 3</u>												
4.10.8	Heater Current:	Note 4	—	—	If:	—	565	600	635	—	52	mA
4.10.8	Heater Current:		0.65	II	If:	540	—	—	—	660	—	mA
4.10.15	Heater-Cathode Leakage:	Ehk= +25 Vdc Ehk= -100 Vdc	0.65	II	Ihk:	—	—	—	—	15	—	uAde
			0.65	II	Ihk:	—	—	—	—	15	—	uAde

# CV4018

Ref.	Test	Conditions	AQL (%)	Insp. Level or Code	Sym.	LIMITS					Units
						Min.	LAL	Bogie	UAL	Max.	
<u>Measurements Acceptance Tests, Part 1, Note 3, Continued</u>											
4.10.17.1	Grid Voltage(1):	Epp=460 Vac; Rgl=0.1 Meg; Rp=3000; Notes 4, 6, and 7	—	—	Ecl1:	—	-3.4	-3.7	-4.0	-.70	Vdc
4.10.17.1	Grid Voltage(1):	Epp=460 Vac; Rgl=0.1 Meg; Rp=3000; Notes 6 and 7	0.65	II	Ecl1:	-2.9	—	—	—	-4.5	Vdc
4.10.17.1	Grid Voltage(2):	Epp=460 Vac; Rgl=10 Meg; Rp=3000; Notes 6 and 7	0.65	II	Ecl1:	—	—	-4.2	—	-5.2	Vdc
4.10.17.2	Anode Voltage(1):	Ecl1=0; Rgl=0.1 Meg; Rp=1000; Notes 4, 6, and 9	—	—	Ebb:	—	—	29	33	—	8.0 Vdc
4.10.17.2	Anode Voltage(1):	Ecl1=0; Rgl=0.1 Meg; Rp=1000; Notes 6 and 9	0.65	II	Ebb:	—	—	—	—	38	Vdc
4.10.17.2	Anode Voltage(2):	Ef=0; Ecl1=-100 Vdc; Rgl=0; Rp=10,000; Notes 6 and 10	0.65	II	Ebb:	650	—	—	—	—	Vdc
—	Operation:	Ebb=500 Vdc approx.; epy=100 v; epy=1000 v; Ecl1=-50 Vdc; Ecc2=0; prr=500 pps; Zo=25; RL=20; Note 31	0.65	II	ib:	16	—	—	—	—	a
4.10.24	Pulse Emission:	Ef=6.3 Vac; epp=egg1=egg2=180 < 9 v; tp=5/0.25us; tr=0.5 us (max); tf=1.0 us (max); prr=100 < 5 pps; Note 21	0.65	II	etd:	—	—	—	—	76	v
4.7.5	Continuity and Shorts: (Inoperatives)	Note 22	0.4	II	—	—	—	—	—	—	—
4.9.1	Mechanical:	Envelope Outline No. (6-2)	—	—	—	—	—	—	—	—	—
<u>Measurements Acceptance Tests, Part 2</u>											
4.8	Insulation of Electrodes:	Ef=6.3 V; Note 23; Eg2-p= < 380 Vdc	2.5	IA	Rg2-p:	760	—	—	—	—	Meg
4.10.17.2	Anode Voltage(3):	Ef=5.7 V; Ecl1=0; Rgl=0.1 Meg; Rp=1000; Notes 6, 9 and 24	2.5	II	Ebb:	—	—	—	—	50	Vdc

Ref.	Test	Conditions	AQL (%)	Insp. Level or Code	Sym.	LIMITS						Units
						Min.	LAL	Bogie	UAL	Max.	ALD	
<u>Measurements Acceptance Tests, Part 2</u> (Continued)												
4.10.17.1	Grid Voltage(3):	Ef=7.0 V; Epp=4.60 Vac; Rgl=10 Meg; Rp=3000; Notes 6, 7 and 25.	6.5	IA	Eccl:	---	---	---	---	-6.4	---	Vdc
---	Grid #2 Voltage:	Epp=150 Vac; Eggl=16 Vac; Rp=1000; Rgl=2500; Notes 26 and 27	6.5	IA	Egg2:	1.9	---	2.6	---	3.3	---	Vac
4.9.19.1	Vibration(2):	No Voltages	6.5	I		---	---	---	---	---	---	
<u>Degradation Rate Acceptance Tests, Note 8</u>												
4.9.20.5	Shock:	Hammer Angle=48°	20	---		---	---	---	---	---	---	
4.9.20.6	Fatigue:	G=2.5; F=25 min, 60 max; Fixed Frequency	6.5	Note 5		---	---	---	---	---	---	
---	Post Shock and Fatigue Test End Points:	Heater-Cathode Leakage Ehk=725 Vdc Ehk=100 Vdc Anode Voltage(1) Pulse Emission Grid Voltage(1)	---	---	Ihk: Ihk: Ebb: etd: Eccl:	---	---	---	---	40 40 50 76 -4.5	---	uAde uAde Vdc v Vdc
---	Glass Strain:	Note 11	2.5	I		---	---	---	---	---	---	
4.9.6.1	Glass Strain:		---	---		---	---	---	---	---	---	

# CV4018

Ref.	Test	Conditions	ACL (%)	Insp. Level or Code	Allowable Defectives per Characteristic		Sym.	LIMITS		Units
					1st Sample	Combined Sample		Min.	Max.	
<u>Acceptance Life Tests, Note 8</u>										
4.11.7	Heater Cycling Life Test:	Ef=7.5 V; Ehk= -100; Ec1=Ec2=Eb=0; Note 12	1.0	---	---	---		---	---	
4.11.4	Heater Cycling Life Test End Points:	Heater-Cathode Leakage Ehk= /25 Vdc Ehk= -100 Vdc	---	---	---	---	Ihk: Ihk:	---	20	uAdc
								---	20	uAdc
---	Stability Life Test: (1 hour)	Epp=460 Vac; Rp/Ib=80mAdc (min); Rgl=50,000; Rp/Ib=500 ma (min); TA Room; tk=20 sec; Notes 6, 13 and 28	1.0	I	---	---		---	---	
4.11.4	Stability Life Test End Points:	Grid Voltage(1)	---	---	---	---	Eccl: Eccl:	-2.8	-4.6	Vdc
								---	15%	
---	Survival Rate Life Test: (100 hours)	Stability Life Test Conditions or equivalent; Notes 6, 14, 15, 28 and 30	---	II	---	---		---	---	
4.11.4	Survival Rate Life Test End Points:	Continuity and Shorts Grid Voltage(1)	0.65 1.0	---	---	---	Eccl:	---	---	Vdc
								-2.0	-4.8	
4.11.5	Intermittent Life Test:	Stability Life Test Conditions; T Envelope=150°C min; Notes 6, 16, 17 and 28	---	---	---	---		---	---	
4.11.4	Intermittent Life Test End Points: (500 hours)	Note 18 Inoperatives; Note 19 Heater Current Grid Voltage(1) Anode Voltage(1) Pulse Emission Heater-Cathode Leakage Ehk= / 25 Vdc Ehk= -100 Vdc Insulation of Electrodes g2-p	---	---	1 1 1 1 2	3 3 3 3 5	If: Eccl: Ebb: std: Ihk: Ihk: R:	---	---	mA Vdc Vdc v
					1 3	3 3		540 -2.0 ---	670 -4.8 50 100	uAdc uAdc
		Total Defectives	---	---	4	8		380	---	Meg
4.11.4	Intermittent Life Test End Points: (1000 hours)	Note 18 Inoperatives; Note 19 Heater Current Grid Voltage(1) Heater-Cathode Leakage Ehk= / 25 Vdc Ehk= -100 Vdc	---	---	2 2 2	5 5 5	If: Eccl: Ihk: Ihk:	---	---	mA Vdc
					2 5	5 5		540 -1.6	680 -4.8	uAdc uAdc
		Total Defectives	---	---	5	10		---	---	

Ref.	Test	Conditions	AQL (%)	Insp. Level or Code	Allowable Defectives per Characteristic		Sym.	LIMITS		Units
					1st Sample	Combined Sample		Min.	Max.	
4.11	<u>Acceptance Life Tests, Note 8 (Continued)</u>									
	Continuous Life Test: (200 hours)	Group A; epy=500 v (approx); egy=100 v (max); Ecc1=-50 Vdc; Ecc2=0; Zc=12.5; RI=7.5; Notes 29 and 32								
4.11.4	Continuous Life Test End Points:	Pulse Emission Continuous Life Test conditions; Note 20					etd: ib:	— 16	100 —	v a
4.9.18.1.6	<u>Packaging Requirements</u>									
	Container Drop:	(d) Package, Group 1; Carton Size B								

Note 1: After completion of a pulse, a 20 us delay is required before a positive voltage of more than 10 v is applied to the tube.

Note 2: Averaged over any interval of 30 seconds maximum.

Note 3: The AQL for the combined defectives for attributes in Measurements Acceptance Tests, Part 1, excluding Inoperatives and Mechanical shall be one (1) percent. A tube having one (1) or more defects shall be counted as one (1) defective. MIL-STD-105, Inspection Level II shall apply.

Note 4: Variables Sampling Procedure:

Test for Lot Average Acceptance, Using Mean:

Select a 35 tube sample at random from the lot. Number these tubes consecutively.

Determine the numerical average value of the characteristic as specified on the specification sheet of the 35 tube sample. If this value is on or above the LAL and on or below the UAL, accept for Lot Average.

Test for Lot Dispersion Acceptance, Using Average Range:

Divide the 35 tube sample into seven (7) consecutive sub-groups of five (5) tubes each. Determine the range, R, of each sub-group for the measured characteristic specified on the Tube Specification Sheet.

Compute the  $\bar{R}$  which is the average of the R values. If  $\bar{R}$  is equal to or less than the ALD, accept for Lot Dispersion.

Alternate Method, Variables Sampling Procedure:

Test for Lot Average Acceptance, Using Median:

Select a 35 tube sample at random from the lot.

Test for all electrical characteristics for which variable acceptance limits are shown on the TSS.

Arrange the 35 measurements in the order of magnitude.

Find the value of the 18th measurement of the sample so arranged. This is the median ( $\tilde{X}$ ) of the sample of 35.

## CV4018

Note 4 : If  $(\bar{X})$  is on or above the LAL and on or below the UAL, accept for lot average.  
(Contd)

Test for Lot Dispersion Acceptance, Using Quasi-Range:  
Arrange the 35 measurements in order of magnitude.

Find the difference between the 3rd and 33rd measurements of the samples so arranged. This is the quasi-range (QR) of the sample of 35.

Multiply this quasi-range by 0.83.

If QR multiplied by 0.83 is equal to or less than the AID, accept the characteristic for lot dispersion.

Note 5 : This test shall be conducted on the initial lot and thereafter on a lot approximately every 30 days. Once a lot has passed, the 30-day rule shall apply. In the event of lot failure, the lot shall be rejected and the succeeding lot shall be subjected to this test. MIL-STD-105, sample size code letter F shall apply.

Note 6 : Connect Pins 5 and 7 to Pin 2.

Note 7 : Use miniature steatite socket with grounded shield base. Shield the plate power supply. Use short shielded plate and grid leads. Plate and grid resistors shall be noninductive. Connect the grid resistor directly at the socket.

Note 8 : Destructive Tests:

Tubes subjected to the following destructive tests are not to be accepted under this specification.

4.9.20.5	Shock
4.9.20.6	Fatigue
4.11.7	Heater-Cycling Life Test
4.11.5	Intermittent Life Test
4.11	Continuous Life Test

Note 9 : Increase Ebb supply slowly and read Ebb at which conduction occurs.

Note 10: No voltages shall be applied to tube for 20 minutes minimum preceding this test.

Note 11: Glass Strain Procedures - All tubes submitted to this test shall have been sealed a minimum of 48 hours prior to conducting this test. All tubes shall be at room temperature. The entire tube shall be immersed in water not less than 97°C for 15 seconds and immediately thereafter immersed in water not more than 50C, for 5 seconds. The volume of water shall be large enough so that the temperature will not be appreciably affected by the test. The method of submersion shall be in accordance with Drawing #245-JAN, and such that a minimum of heat is conducted away by the holder used. The tubes shall be placed in the water so that no contact is made with the containing vessel, nor shall the tubes contact each other. After the 5-second submersion period, the tubes shall be removed and allowed to dry at room temperature on a wooden surface. After drying at room temperature for a period of 48 hours, the tubes shall be inspected and rejected for evidence of air leaks. Electrical rejects, other than inoperatives, may be used in the performance of this test. The statement in "Inspection Instructions for Electron Tubes", paragraph 5.3.6.1, which defines an air leak as "any tube which shows a grid current of 1.0 uAdc or twice the maximum limit, whichever is greater, shall be considered an inoperative" shall not apply.

Note 12: The no-load to steady state full load regulation of the heater voltage supply shall be not more than 3.0 percent. This test shall be made on a lot by lot basis. A failure or defect shall consist of an open heater, open cathode circuit, heater cathode short, or heater cathode leakage current in excess of the specified heater cycling life test end point limit.

Note 13: Stability Life Test:

- Life test samples shall be selected from a lot at random in such a manner as to be representative of the lot. If such selection results in a sample containing tubes which are outside the initial specification sheet limits for the relevant life test end point characteristic, such tubes shall be replaced by randomly selected acceptable tubes.
- Serially mark all tubes from the sample.

- Note 13: (Contd)
- c. Record referenced characteristic measurements after a maximum operation of 15 minutes under specified voltage and current conditions on the entire sample.
  - d. Operate at life test conditions for one (1) hour (plus 30 minutes, minus 0 minutes). Life test shall be conducted as per paragraphs 4.11 and 4.11.5, MIL-E-1, except that the following shall be substituted for the third sentence of 4.11: The mean electrode potentials, except heater or filament, may be established at values differing by not more than 5% from the specified values provided the same average anode current is obtained that occurs with the specified voltages. Fluctuations of all voltages including heater or filament voltage shall be as small as practical.
  - e. Record referenced characteristic measurements at the end of this test period. Referenced characteristic measurements shall be taken immediately following the test or tubes shall be preheated 15 minutes under specified test voltages and current conditions, and immediately measured. The 15 minutes preheat shall be considered as part of the test time.
  - f. A defective shall be defined as a tube having a change in referenced characteristic greater than that specified on the specification sheet.
  - g. A resubmitted lot must be subjected to all Measurements-Acceptance Tests except Mechanical Inspection and Vibration tests.

Note 14: Means of Assuring Survival Rate - The procedure for assuring the maintenance of a desirable quality level in terms of early life survival consists of a series of normal, reduced, and tightened inspection plans for use at 100 hours. The sample size is dependent upon lot size, and the transfer between normal, reduced, and tightened inspection is dependent upon quality history.

The selection of inspection scheme and sampling plan shall be in accordance with Inspection Instructions for Electron Tubes paragraph 5.3.4.2 through 5.3.4.3.1.3 inclusive except that paragraph 5.3.4.2.2 shall be modified by deleting the last part of the first sentence which states "... or if no lot in the last 20 lots inspected shall have been declared nonconforming for life test qualities". At the manufacturer's option, reduced inspection may be used if no lot in the last ten (10) lots inspected have been declared nonconforming.

Inspection Procedure:

- a. Select sample in accordance with Note 13, paragraph (a).
  - b. Tubes to be tested at 100 hours as provided in MIL-E-1 (4.7.5). When any tap-short indication is obtained, the test shall be repeated. When any short indication is again obtained the tube will be rejected as an inoperative. The statement in "Inspection Instructions for Electron Tubes", paragraph 5.3.6.1, which reads "any tube which shows a grid current reading of 1.0 uadc or twice the maximum limit for grid current, whichever is greater, shall be considered an inoperative" shall not apply.
  - c. Determine the number of defective tubes at the 100 hour period.
  - d. If more than the allowable number of defectives occur, declare the lot nonconforming.
  - e. A resubmitted lot must be subjected to all Measurements Acceptance Tests except Mechanical Inspection and Vibration tests.
- Note 15: For Survival Rate Life Test, the equivalent Stability Life Test conditions shall be interpreted as having the same heater voltage ( $E_f$ ) as the Stability Life Test; and the same interruptions of MIL-E-1 paragraph 4.11.5 as the Intermittent Life Test. The electrode voltages shall be such that the average anode current is not less than 80 percent, or more than 100 percent of Stability Life Test average anode current.

Note 16: Intermittent Life Tests:

- a. The first 20 tubes of the Stability Life Test sample which meet the measurements acceptance test limit for those characteristics specified as Intermittent Life Test End Points may be used for the Intermittent Life Test sample. In the event that a second Stability Life Test sample is used, the first 20 tubes from that sample which meet the above conditions shall be used.



## CV4018

- Note 16: (Contd)
- b. In the event of failure of the first sample on Intermittent Life Test, take a completely fresh sample (MIL-STD-105 sample size code letter I) and stabilize it in accordance with the conditions of the Stability Life Test. Then select from it the first 40 tubes which meet the measurements acceptance test limits for those characteristics specified as Intermittent Life Test End Points. Subject these 40 tubes to the Intermittent Life Test. Acceptance shall be based on combined results from the first and second samples.
  - c. As an alternate method, the manufacturer may select his life test sample as described in Note 13, paragraph (a).
  - d. Regular Life Test:
    1. Regular Life Test shall be conducted for 1000 hours.
    2. Regular Life Test acceptance shall be on the basis of the 500 and 1000 hour requirements as indicated on the Specification Sheet.
    3. Regular Life Test shall be in effect initially and shall continue in effect until the eligibility criteria for the Reduced Hours Life Test have been met.
  - e. Reduced Hours Life Test:
    1. Reduced Hours Life Test shall be conducted for 500 hours and acceptance shall be based on the 500 hour end point limits.
    2. Eligibility for Reduced Hours Life Tests: No lot failure due to the 1000 hour life test has occurred in the preceding three (3) consecutive lots.
    3. Loss of eligibility for Reduced Hours Life Tests: Two (2) or more 500 hour life test lot failures occurring in the last three (3) consecutive lots.
  - f. The life test sample shall be read at the following times:
    - 0 hours
    - 500 hours (plus 48 hours; minus 24 hours)
    - 1000 hours (plus 48 hours; minus 24 hours; when in force)

Additional reading periods may be used at the discretion of the electron tube manufacturer.
  - g. Acceptance: The lot shall be considered satisfactory for acceptance provided that:
 

The specified allowable defects are not exceeded.
  - h. A resubmitted lot must be subjected to all Measurements Acceptance Tests except Mechanical Inspection and Vibration.
  - i. Not more than one (1) accidental breakage shall be allowed in the life test sample. If one (1) life test tube is accidentally broken, acceptability of the life test sample shall be based upon the remaining tubes in the sample provided that the broken tube was not known to be a defective.
- Note 17: Envelope Temperature is defined as the highest temperature indicated when using a thermocouple of #40 BS or smaller diameter elements welded to a ring of .025 inch diameter phosphor bronze in contact with the envelope. The envelope temperature requirement will be satisfied if a tube having bogie plate current ( $\leq 5\%$ ) under normal test conditions is determined to operate at the minimum specified temperature in any socket position on the life test rack.
- Note 18: Order for Evaluation of Life Test Defects:  
If a tube is defective for more than one attribute characteristic, the characteristic appearing first in the Life Test End Points shall constitute the failure.
- Note 19: An inoperative as referenced in Life Test is defined as a tube having one (1) or more of the following defects: discontinuity (Ref. MIL-E-1, paragraph 4.7.1), shorts (Ref. MIL-E-1, paragraph 4.7.2).

# CV4018

MIL-E-1/83A

Note 20: Thirty (30) seconds shall be the maximum time under test conditions before reading  $i_b$ . There shall be no evidence of amplitude jitters.

Note 21: The tube shall be tested in the following circuit:

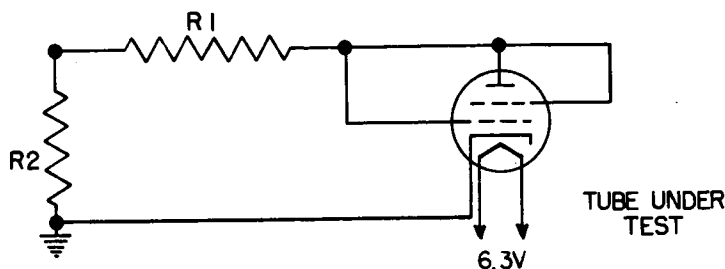

R1 = 10  $\pm$  5% noninductive  
R2 = 15  $\pm$  5% noninductive

(a) A dummy calibrating tube containing a 5  $\pm$  5% ohm noninductive resistance shall be used for calibration and maintenance. The calibrated pulse voltage amplitude shall be within specified values over 80% of the top portion of the pulse. No portion shall exceed 198 volts maximum amplitude.

(b) The tube shall be preheated at  $E_f=6.3V$ . The tube shall be transferred within 3 seconds to the test socket and preheated with  $E_f=6.3V$  only for a minimum of 5 seconds immediately before the application of pulse voltage.

(c) The maximum testing time is 3 seconds.

- Note 22: Inoperatives shall be defined in accordance with the requirements of the Short and Continuity Test, MIL-E-1, paragraph 4.7.5., and "Inspection Instructions for Electron Tubes", dated 5 Oct. 1955, paragraph 5.3.6. The statement "any tube which shows a grid current reading of 1.0  $\mu$ adc or twice the maximum limit for grid current, whichever is greater, shall be considered as an inoperative" shall not apply.
- Note 23: Bead electrode insulation between G2 and plate with all other elements floating.
- Note 24: Preheat using  $E_f=5.7 V$ .
- Note 25: Preheat for 15 minutes under the following conditions:  $E_f=7.0V$ ,  $E_{pp}=220 Vac$ ;  $E_{c1} = E_{c2} = 0$ ;  $R_{g1} = 10 Meg$ ;  $I_b=100 mAdc$ . Two (2) seconds shall be the maximum time between preheat and test.
- Note 26:  $E_{g1}$  supply shall be in phase with  $E_{pp}$  supply and  $E_{g2}$  supply 180° out of phase with  $E_{pp}$  supply.
- Note 27: Vary  $E_{g2}$  supply and read  $E_{g2}$  at which conduction occurs.
- Note 28: Phase of grid voltage adjusted to provide start of conduction at peak applied anode voltage.
- Note 29: Average life is equal to 90% minimum calculated as 4.3.1 of the "Inspection Instructions for Electron Tubes".
- Note 30: At the end of 100 hours, those tubes which meet the initial test requirements shall not be considered as having undergone a destructive test.

- Note 31: Thirty seconds maximum in the operation test socket is permitted before reading. There shall be no evidence of amplitude jitter. The tube shall be tested in the circuit shown in Figure 1. The circuit constants shall be so chosen that: at  $e_{py} = 1000$  v. under resonant charging conditions,  $dik/dt = 100$  a/us minimum,  $t_p = 2.0$  us  $\pm 10\%$ ,  $prr = 500$ pps. The grid pulse characteristics at  $e_{gy} = 100$ v shall be :  $t_p = 2.0$ us maximum,  $t_r = 0.5$  us minimum, driver impedance = 500 ohms minimum.
- Note 32: Adjust  $e_{py}$  for  $i_b = 20$  a initially, and maintain this  $e_{py}$  value throughout the life test. The tube shall be tested in the circuit shown in Figure 1. The circuit constants shall be so chosen that: at  $e_{py} = 500$  v under resonant charging conditions,  $dik/dt = 100$  a/us minimum,  $t_p = 2.0$  us  $\pm 10\%$ ,  $prr = 1000$  pps. The grid pulse characteristics at  $e_{gy} = 100$  v shall be :  $t_p = 2.0$  us maximum,  $t_r = 0.5$  us minimum, driver impedance = 500 ohms minimum.
- Note 33: Reference specification shall be of the issue in effect on the date of invitation for bid.

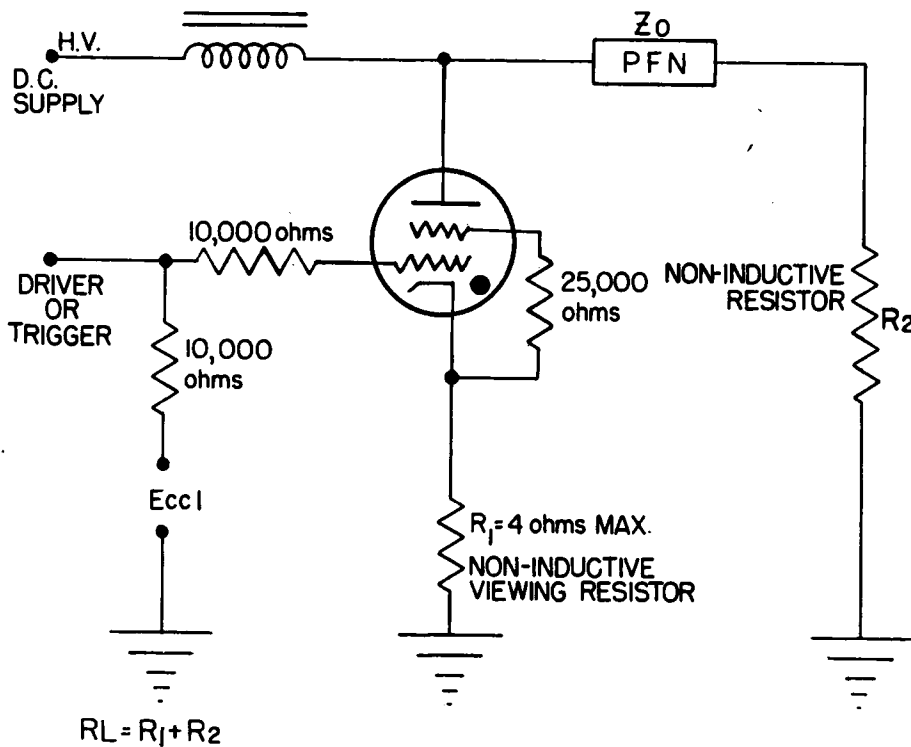

Fig. 1