

For frequencies up to 30 MHz

Ordering code Q53-X2031

Vapor-cooled triode with coaxial grid lead-through. Due to the low amplification factor this tube is particularly suitable for use in modulators with low grid current.

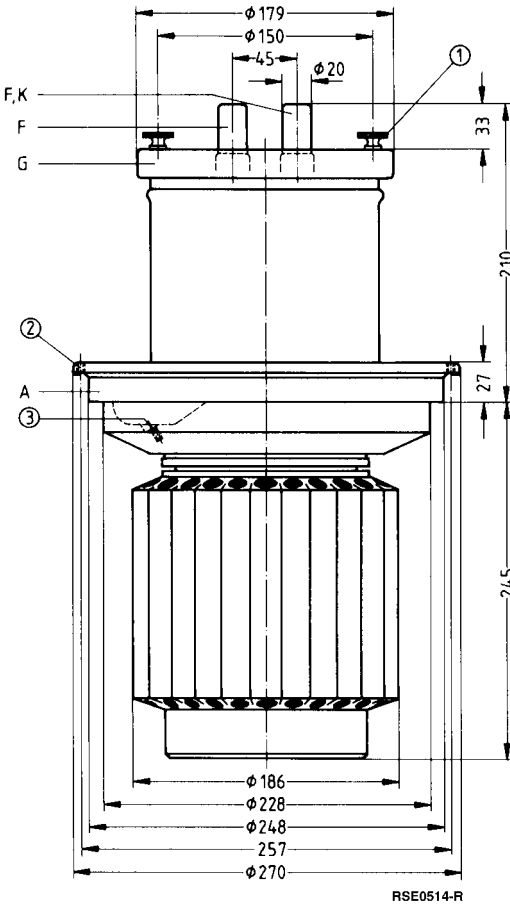

Dimensions in mm

- ① 4 tapholes M5 (4 × 90°)
- ② Taphole M6 for screw-in handle R6Zub201K
- ③ Taphole M5 for tube fuse R6Sich4

Approx. weight 34 kg

Heating

Heater voltage	U_F	17	V
Heater current	I_F	≈ 156	A
Heating: direct			
Cathode: thoriated tungsten			

Characteristics

Emission current at $U_A = U_G = 750\text{ V}$	I_{em}	125	A
Amplification factor at $U_A = 4\text{ to }10\text{ kV}$, $I_A = 5\text{ A}$	μ	13,5	
Transconductance at $U_A = 4\text{ kV}$, $I_A = 5\text{ A}$	s	78	mA/V

Capacitances

Cathode/grid	C_{kg}	≈ 175	pF
Cathode/anode	C_{ka}	≈ 8,0	pF 1)
Grid/anode	C_{ga}	≈ 76	pF

Accessories

Ordering code

Mounting instruction	RöMo14	
Mounting instruction	RöMo25	
Cathode connecting strip (2 for each tube)	RöKat41	Q81-X1141
Socket wrench for tube fuse	RöZub10	Q81-X2110
Handle	RöZub201K	Q81-X2151
Tube fuse	RöSich4	Q81-X1404
Pull switch for tube fuse	RöKt11	Q81-X1311
Boiler	RöKüV201	Q81-X1671
Union at water inlet	RöKüV41Zub7	Q81-X1647
Insulating pipe at vapor outlet	RöKüV201Zub3	Q81-X1673
Insulating pipe at water inlet	RöKüV201Zub4	Q81-X1674
Insulator	RöKüV201Zub5K	Q81-X1675
Gasket at vapor outlet	RöKüV201Zub8	Q81-X1678
Water level stabilizer with control electrodes	RöZubV4	Q81-X2105
LL electrolytic target	RöEI23	C65055-A667-A23
Gasket for boiler	RöN9355	C65051-A201-C531

1) Measured by means of a 40 cm × 40 cm screening plate in the grid terminal plane.

**RF amplifier,
class B operation, grounded cathode circuit**

Maximum ratings

Frequency	f	30	MHz
Anode voltage (dc)	U_A	12,5	kV
Grid voltage (dc)	U_G	- 1200	V
Cathode current (dc)	I_K	25	A
Peak cathode current	I_{KM}	100	A
Anode dissipation	P_A	110	kW
Grid dissipation	P_G	1100	W

Operating characteristics

Frequency	f	≤ 30	≤ 30	MHz
Output power	P_2	165	110	kW ¹⁾
Anode voltage (dc)	U_A	12	10	kV
Grid voltage (dc)	U_G	- 900	- 730	V
Peak control grid voltage (ac)	$U_{g,m}$	1300	1100	V
Zero signal anode current (dc)	I_{A0}	1,5	1,5	A
Anode current (dc)	I_A	18,8	15,3	A
Grid current (dc)	I_G	1,6	1,3	A
Anode input power	P_{BA}	226	153	kW
Drive power	P_1	2,0	1,3	kW ¹⁾
Anode dissipation	P_A	61	43	kW
Grid dissipation	P_G	600	350	W
Efficiency	η	73	72	%
Anode load resistance	R_A	370	370	Ω

1) Circuit losses are not included.

**RF amplifier,
class C operation, grounded cathode circuit**

Maximum ratings

Frequency	f	30	MHz
Anode voltage (dc)	U_A	12,5	kV
Grid voltage (dc)	U_G	- 1500	V
Cathode current (dc)	I_K	25	A
Peak cathode current	I_{KM}	100	A
Anode dissipation	P_A	110	kW
Grid dissipation	P_G	1100	W

Operating characteristics

Frequency	f	≤ 30	≤ 30	MHz
Output power	P_2	165	110	kW ¹⁾
Anode voltage (dc)	U_A	12	10	kV
Grid voltage (dc)	U_G	- 1350	- 1200	V
Peak grid voltage (ac)	U_{gm}	1830	1630	V
Anode current (dc)	I_A	17	13,8	A
Grid current (dc)	I_G	2,0	1,8	A
Anode input power	P_{BA}	204	138	kW
Drive power	P_1	3,3	2,7	kW ¹⁾
Anode dissipation	P_A	39	28	kW
Grid dissipation	P_G	600	500	W
Efficiency	η	81	80	%
Anode load resistance	R_A	370	370	Ω

1) Circuit losses are not included.

**AF amplifier and modulator,
class B operation, 2 tubes in push-pull circuit**

Maximum ratings

Anode voltage (dc)	U_A	12	kV
Grid voltage (dc)	U_G	- 1200	V
Cathode current (dc)	I_K	25	A
Peak cathode current	I_{KM}	100	A
Anode dissipation	P_A	110	kW
Grid dissipation	P_G	1100	W

Operating characteristics

at modulator operation for

		300 kW carrier power		200 kW carrier power		
Output power	P_2	0	240	0	160	kW
Anode voltage (dc)	U_A	11	11	11	11	kV
Grid voltage (dc)	U_G	- 810	- 810	- 830	- 830	V
Peak control grid voltage (ac) between the 2 tubes	U_{ggm}	0	2120	0	1980	V
Anode current (dc)	I_A	2 × 1,5	2 × 18	2 × 1	2 × 11,7	A
Grid current (dc)	I_G	0	2 × 0,6	0	2 × 0,25	A
Peak grid current	I_{GM}	0	2 × 4,3	0	2 × 2,2	A
Anode input power	P_{BA}	2 × 16,5	2 × 198	2 × 11	2 × 129	kW
Drive power	P_1	0	2 × 600	0	2 × 180	W
Anode dissipation	P_A	2 × 16,5	2 × 78	2 × 11	2 × 49	kW
Grid dissipation	P_G	0	2 × 120	0	2 × 40	W
Efficiency	η	—	61	—	62	%
Effective load resistance (anode to anode)	R_{AA}	—	600	—	950	Ω

Tube mounting

Axis vertical, anode down.

For connection of the cathode use the terminals listed under “Accessories”.

A number of M5 tapholes is provided at the grid terminal ring for grid connection; the delivery includes knurled head screws for this purpose.

Maximum tube surface temperature

The temperature of the glass and metal parts and of the cathode terminals must not exceed 220 °C at any point. At $f > 10$ MHz a properly distributed, slight air stream has to be directed onto the grid terminal ring and the cathode terminal pins.

Vapor cooling

Cooling specifications for maximum anode dissipation	$P_{A \max} = 110 \text{ kW}$
Total power to be dissipated by the cooling system ($P_A + P_G + 0,8 P_F$)	114 kW
Equivalent thermal output	6820 kJ/min (1640 kcal/min)
Flow rate of returning water	
at returning water temperature of 20 °C	approx. 2,7 l/min
at returning water temperature of 90 °C	approx. 3,1 l/min
Volume of generated vapor	
at returning water temperature of 20 °C	approx. 4,5 m ³ /min
at returning water temperature of 90 °C	approx. 5,1 m ³ /min

Detailed information on vapor cooling upon request. Please observe instructions on vapor cooling given under “Explanations on Technical Data”.

Safety precautions

The section “Safety precautions” under “Explanations on Technical Data” describes how the tube is to be protected against damage due to electric overload or insufficient cooling. A copper wire with 0,24 mm diameter should be used to test the anode overcurrent trip circuit.

For protection against thermal anode overload the tube fuse R6Sich4 is recommended. In conjunction with pull switch R6Kt11 it disconnects the voltages at the tube in case of overload (accessories).

$U_G = f(U_A)$ Parameter = I_A —————
 Parameter = I_G - - - - -

