

December 29, 1958

FLUX MAPPING FISSION CHAMBER TYPE WL-7186

The WL-7186 is a miniature fission chamber 0.5 inch long and 0.25 inch in diameter, with an integral rigid coaxial cable four feet in length. Ionization pulses are produced in the nitrogen-argon atmosphere by fission fragments resulting from thermal neutrons incident on the sensitive coating, which consists of uranium oxide highly enriched in the U-235 isotope. The WL-7186 is rugged in construction and will operate in any position and at temperatures up to 125°C. The exposed portions of the chamber and integral cable are of stainless steel, thereby permitting operation of the sensitive volume under water. §

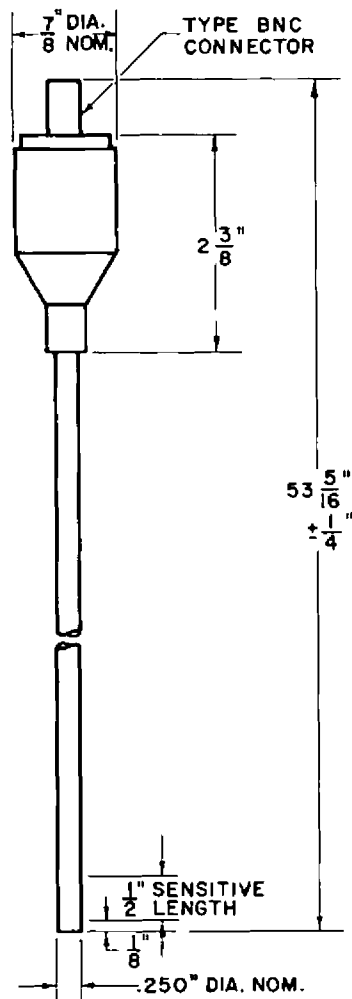

MECHANICAL:

Body Diameter (Max.)	1/4	Inches
Head Diameter (Max.)	7/8	Inches
Overall Length (Max.)	53-9/16	Inches
Weight	1/2	Pound

MATERIALS:

Body	Stainless Steel
Center Electrode	Steel
Head	Brass
Insulation	Teflon and Alumina
Gas Filling	Argon-Nitrogen
Neutron Sensitive Coating	U ₃ O ₈ Enriched to More Than 90% in U-235

MAXIMUM RATINGS:

Voltage Between Electrodes	500	Volts
Temperature	125	°C

OPERATIONAL:

Output Impedance	10 ⁹ ohms, 55 uuf
Thermal Neutron Sensitivity (Approx.)	0.001 cps/nv
Operating Voltage Range	250 to 400 Vdc
Output Pulse Characteristics:	
Magnitude	10 ⁻⁴ Volts
Inherent Rise Time	2 x 10 ⁻⁷ Seconds
Overall Gain of Amplifiers	50000

§ In operating the unit partly immersed, care must be taken to keep the connector free of water.

COUNTER SENSITIVITY AS A FUNCTION OF PULSE HEIGHT SELECTOR SETTING

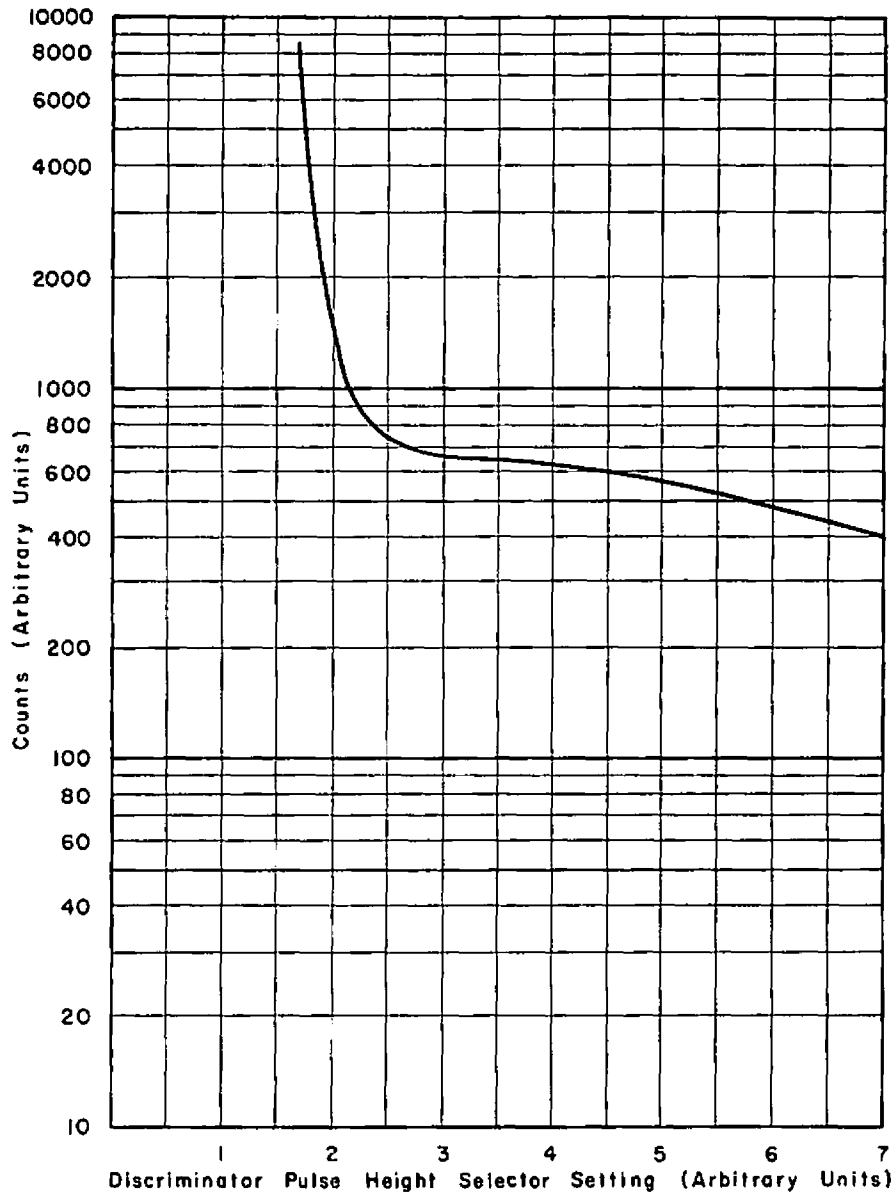

CE-A1370